



BX1636

1999-04 Chevrolet Tracker 2000-05 Suzuki Vitara Installation Instructions

Serial Number

Please read **BOTH** these Installation Instructions and the General Towing Instructions before attempting to install or operate this equipment.

Attachment Tab Height: 16-3/4"

Attachment Tab Width: 25-1/2"

- Blue Ox® towing products and accessories are intended to be installed by Blue Ox® Dealers who are familiar with our products and have the equipment and knowledge to do "fit work". When necessary Blue Ox® Dealers can be found at www.blueox.com or by contacting our Customer Care Department at (402) 385-3051.
- Many Blue Ox® Baseplates are designed to use existing holes and hardware to mount the baseplate to the towed vehicle. Even though bolts are there, do not assume they are adequate for baseplate mounting. Always use hardware supplied in the hardware kit or existing hardware specified in the Baseplate Towing Installation Instructions.

Bolt Torque Specifications
Torque in Foot-Pounds for Metric Bolts

Bolt Size	Grade 8.8	Grade 10.9
6MM	6	8
8MM	16	22
10MM	31	40
12MM	54	70
14MM	89	117

Confirm the towability and pre-towing procedures for your vehicle with the owner's manual or contact the vehicle's manufacturer for specific towing procedures.

Bolt Torque Specifications
Torque in Foot-Pounds for Inch Bolts

Bolt Size	Grade 5	Grade 8
1/4"	10	14
5/16"	19	29
3/8"	33	47
7/16"	54	78
1/2"	78	119
5/8"	154	230

WARNING

Failure to read and follow these instructions could result in separation of the towed vehicle from the tow bar, causing property damage, loss of towed vehicle, personal injury or death.

BX1636
1999-04 Chevrolet Tracker
2000-05 Suzuki Vitara
Installation Instructions

Parts List

Ref. No.	Qty.	Part #	Description
1	6	61-5208	3/8 Nut Plate, 1/4" x 1" x 1" with Wire
2	6	201-0368	3/8-16 x 1 1/4" Hex Bolt, Grade 5
3	6	203-0010	3/8" Lock Washer
4	1	61-5458	Baseplate, BX1636
5	2	201-0553	1/4-20 x 1/2" Hex Bolt
6	2	101-5822	Adapter, 4 Way Connector
7	2	202-0047	#10-32 Hex Nut
8	2	203-0054	#10 Lock Washer
9	2	201-0192	#10-32 x 1/2" Slot Rd. Hd. Screw
10	2	62-3470	Attachment Tab, Long
	2	226-0046	Baseplate Safety Cable, 36" CL III (Not Shown)
	2	229-0359	Quicklink, 3/8, ZP (Not Shown)
	2	290-0437	Cap Plug, Black (Not Shown)

Tools Required

10MM Wrench
12MM Wrench
1/2" Drill Bit
3/8" Drill Bit
3/4" Wrench
Drill
Utility Knife
Loctite® RED

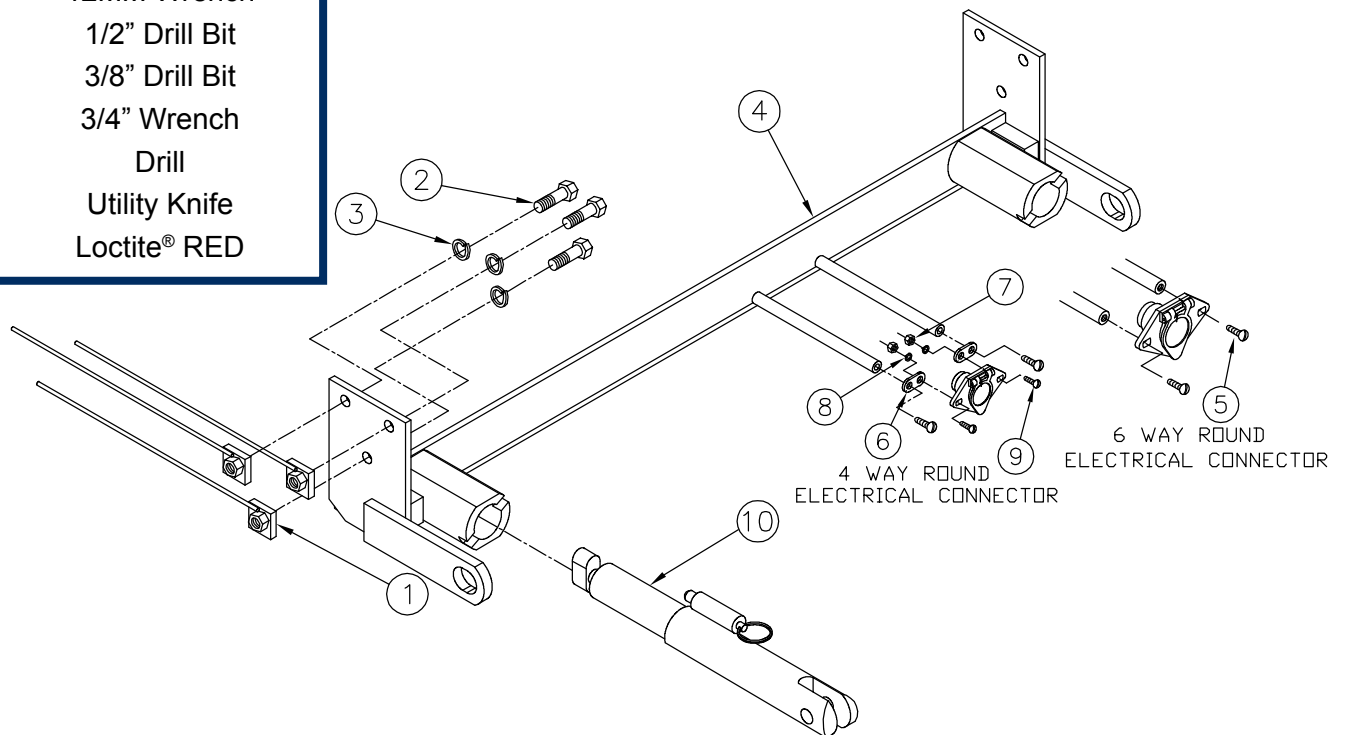

Important:

Use only genuine factory replacement parts on your baseplate. Do **NOT** substitute homemade or non-typical parts. If a bolt is lost or in need of replacement, for your safety and the preservation of your baseplate, be sure to use a replacement bolt of the same grade (In most cases it will be Grade 5, please reference the parts list above). Replacement parts may be ordered through your nearest Blue Ox® Dealer or Distributor.

BX1636
1999-04 Chevrolet Tracker
2000-05 Suzuki Vitara
Installation Instructions

Removable Tabs:

Due to the design of the removable tabs, the RangeFinder II and Ambassador tow bars can not be used. Adapters, except for the BX8833 and the BX88151, can not be used with this baseplate.

Installation Notes:

The baseplate mounts to the main frame of the vehicle. Drilling is required for the installation. The attachment tabs will extend through the grille opening approximately four inches.

The dimensional variations between otherwise identical vehicles can be considerable. While the baseplate was designed for easy installation, it may be necessary to tailor the baseplate slightly to compensate for auto manufacturer's tolerances. These minor adjustments may include filing a hole slightly, bending electrical rods, and/ or bending end plates.

The BX8869 Bulb and Socket Wiring Kit is recommended for this vehicle.

Installation Instructions:

1. Notice the four pins on the top portion of the grille. Remove the pins from the grille and gently pull the grille out of its holding position. (Not on all models)
2. Remove the headlights by removing the three bolts. Set the bolts aside to be reinstalled later. Do this to both sides of the vehicle.
3. Notice the seven pushpins (Phillips head) on the top of the bumper molding. Remove the pushpins. Remove the Phillips head screw in the front of the tire. Do this to both sides of the vehicle. Use a 10MM wrench or socket and remove the bolt just forward of the front tire. Do this to both sides of the vehicle. There are also bolts that need to be removed in front of the tire. Do this to both sides of the vehicle. There are also bolts that need to be removed on the bottom side of the bumper fascia. Gently pull the bumper fascia forward and off its holding position. Set bolts and pushpins aside to be reinstalled later.
4. Remove the bracket assembly on the passenger's side on the back side of the metal bumper. Remove the bolts and unplug electrical connections. Set the metal bumper aside to be reinstalled later. Set the bolts and metal bumper aside to be reinstalled later.
5. Notice the plastic wire loom (located on the passenger's side) on the inside of the metal frame that is attached with a plastic clip, pull out the clip. On the driver's side of the frame is a similar hole, drill both holes out to 3/8" diameter.
6. Hold the baseplate so the front bolt holes are aligned with the drilled holes on the frame. Insert the 3/8" bolts in to the baseplate and existing holes. Notice the small openings on the front of the metal bumper. Insert a wire nut plate and hand tighten the bolts into the nut plate. Hold the baseplate so it is level and mark the other four side plate holes. Once the holes have been marked remove the baseplate from the vehicle.

BX1636
1999-04 Chevrolet Tracker
2000-05 Suzuki Vitara
Installation Instructions

7. Drill the four holes with the 3/8" drill bit. Install the baseplate using the 3/8" hardware (all six wire nut plates will be inserted through the front holes on the metal bumper. Once all six bolts have been started, tighten and torque the bolts according to the torque specifications chart in the Baseplate General Towing Instructions.
8. Replace the inside bracket and connect the wiring from Step #4. Replace the bumper fascia and grille (not all models). Also replace the headlight assemblies and connect the wiring.

Install the tow bar and safety cables according to the instructions included in their packages.

Do NOT substitute other devices if the tow bar pin and clip are lost.

Dealer or Installer: be certain the customer receives the instruction sheet.

CUSTOMER SERVICE COMMITMENT

Blue Ox is committed to providing you with exceptional customer care throughout your lifetime with our products. Our team is here to assist you with any questions you may have regarding the performance of your product. Simply call 1-800-228-9289 and you can speak with our customer care team.

Additionally, please visit our website to see which rallies our Destination America team will be attending. For a nominal fee, our service technician will service your towing system to ensure it's in proper working condition. Also as a commitment to our customers, should you visit our factory you can stay at our full service Blue Ox campground at no charge along with enjoying a factory tour.

Again thank you for being our customer and for the confidence you have shown in the performance of our products. It is because of customers like you we enjoy the success we have today.



© 2006, 07, 08, 09 Blue Ox
One Mill Road, Industrial Park
Pender, Nebraska 68047
Phone: (402) 385-3051
Toll Free: (888) 425-5382
Fax: (402) 385-3360
www.blueox.com
8/3/09