



BX3620

2014-15 Subaru XV Crosstrek 2015 Subaru Impreza 2015-16 Subaru WRX Installation Instructions

Please read **BOTH** these Installation Instructions and the General Information prior to installing or operating this equipment.



XV Crosstrek



Impreza



WRX

If the front of your vehicle looks different than this, please contact us at (402)385-3051.

Serial Number

Attachment Tab Height: 12"

Attachment Tab Width: 20-1/2"

1. Blue Ox® towing products and accessories are intended to be installed by Blue Ox® Dealers who are familiar with our products and have the equipment and knowledge necessary to do "fit work". If needed, Blue Ox® Dealers can be found at www.blueox.com or by contacting our Technical Service Department at (402) 385-3051.
2. Many Blue Ox® baseplates are designed to use existing holes and hardware to mount the baseplate to the towed vehicle. Even though bolts are there, do not assume they are adequate for baseplate mounting. Always use the hardware supplied in the hardware kit and existing hardware as specified in the installation instructions.

WARNING

Failure to read and follow these instructions could result in separation of the towed vehicle from the tow bar, causing property damage, loss of towed vehicle, personal injury or death.

Reference your vehicle owner's manual for manufacturer's towing specifications.

BX3620
 2014-15 Subaru XV Crosstrek
 2015 Subaru Impreza
 2015-16 Subaru WRX
 Installation Instructions

Instruction Notes: The fascia, windshield washer fluid reservoir, frame brace and bumper are removed and reinstalled for the baseplate installation. Some drilling and trimming is required.

Place all components that are removed on a flat, sturdy surface. All items will be reinstalled unless otherwise noted after the baseplate is installed.

The dimensional variations between otherwise identical vehicles can be considerable. While the baseplate was designed for easy installation, it may be necessary to tailor the baseplate slightly to compensate for vehicle manufacturer's tolerances.

The BX8869 Tail Light Wiring Kit is recommended for this vehicle.

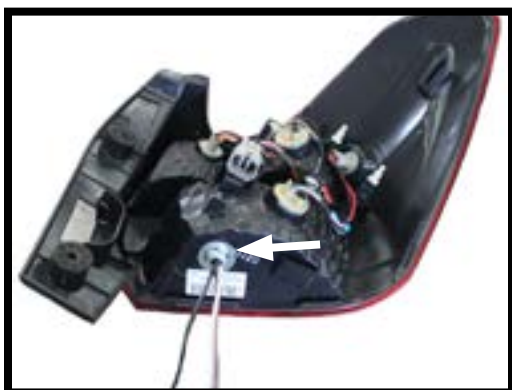

Drill a hole according to the tail light wiring kit instructions.

Bolt Torque Specifications		
Torque in Foot-Pounds for Inch Bolts		
Bolt Size	Grade 5	Grade 8
1/4"	10	14
5/16"	19	29
3/8"	33	47
7/16"	54	78
1/2"	78	119
5/8"	154	230
3/4"	257	380

Bolt Torque Specifications		
Torque in Foot-Pounds for Metric Bolts		
Bolt Size	Grade 8.8	Grade 10.9
6MM	6	8
8MM	16	22
10MM	31	40
12MM	54	70
14MM	89	117
16MM	161	230
18MM	222	318

NOTICE

- Handling of some cosmetic parts when installing this product may require the use of protective covers, rags, specialty tools, etc. to prevent damage.
- When using power drills be aware of the dangers of torque and drill bit length.
- When using a reciprocating saw be aware of objects behind the cutting surface.
- Use a good quality paint to spray cut edges of frame to prevent rusting.
- Be sure that **ALL** electrical connections are plugged in and accessories are functioning properly before reinstalling the fascia.
- The baseplate is computer tested to your vehicle's GVWR, exceeding this weight will void the manufacturer's warranty.
- Be sure to use a sufficient amount of Loctite® Red on all bolt threads before tightening. Tighten all bolts according to the torque chart provided.
- Dealer or installer be certain the user receives these instruction sheets.
- If the baseplate is in an accident, it must be replaced. **DO NOT** use it again! An accident can cause unseen damage and using it again could result in more damage or serious injury. **DO NOT** use the baseplate if it is damaged or missing parts.

BX3620
2014-15 Subaru XV Crosstrek
2015 Subaru Impreza
2015-16 Subaru WRX
Installation Instructions

Tools Required

- Flat Screwdriver
- Utility Knife
- Phillips Screwdriver
- Torque Wrench
- Drill
- Reciprocating Saw
- Tape Measure
- Loctite® RED
- 1/4" Drill Bit
- 3/8" Drill Bit
- 10MM Socket
- 12MM Socket
- 14MM Socket
- 9/16" Socket
- 9/16" Wrench
- 5/16" Nut Driver

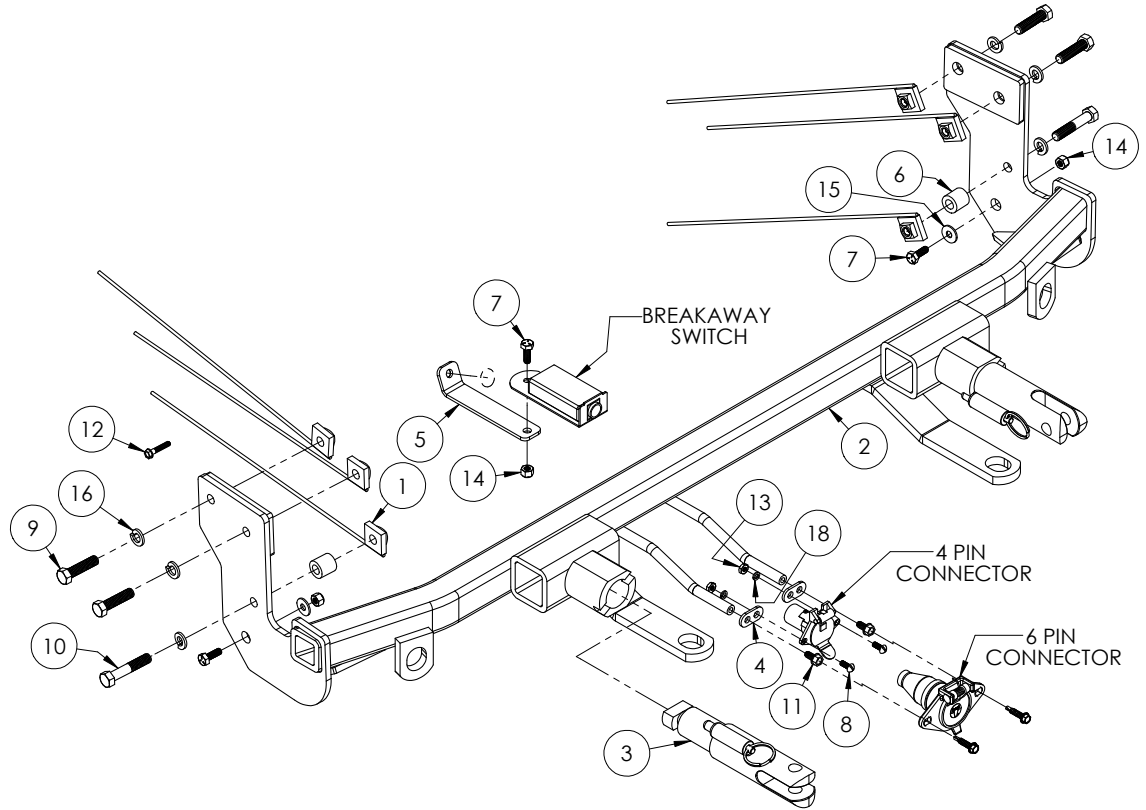

Item No.	Part No.	Description	Qty.
1.....	61-5208.....	3/8"-16 Nut Plate w/ 14" Wire	6
2.....	61-7288.....	BX3620 Baseplate.....	1
3.....	62-3468.....	Attachment Tab Assembly with Hole	2
4.....	101-5822.....	4 Way Connector Adapter	2
5.....	101-8390.....	Breakaway Bracket	1
6.....	107-1753.....	3/4" Spacer Tube.....	2
7.....	201-0050.....	1/4"-20 x 3/4" Hex Head Bolt, Grade 5, ZP	3
8.....	201-0192.....	#10-32 1/2" Round Slotted Head Screw.....	2
9.....	201-0440.....	3/8"-16 x 1-1/2" Hex Head Bolt, Grade 5, ZP	4
10.....	201-0444.....	3/8"-16 x 2" Hex Head Bolt, Grade 5, ZP	2
11.....	201-0979.....	#12-14 x 1" Self Drilling Screw, ZP.....	2
12.....	201-0654.....	#10-16 x 1" Self Drilling Screw, ZP.....	1
13.....	202-0047.....	#10-32 Hex Nut	2
14.....	202-0102.....	1/4"-20 Hex Nylon Nut, ZP	3
15.....	203-0001.....	1/4" Flat Washer, ZP.....	2
16.....	203-0010.....	3/8" Lock Washer, ZP	6
17.....	203-0054.....	#10 Lock Washer, ZP	2
18.....	226-0046(not shown).....	Class III Safety Cables	2
19.....	229-0512(not shown).....	1/2" Quicklink, ZP	2
20.....	290-0437(not shown).....	Black Cap Plug Receiver.....	2

Important:

Use only genuine factory replacement parts on your baseplate. Do **NOT** substitute homemade or non-typical parts. If a bolt is lost or in need of replacement, for your safety and the preservation of your baseplate, be sure to use a replacement bolt of the same grade (In most cases it will be Grade 5, please reference the parts list above). Replacement parts may be ordered through your nearest Blue Ox® Dealer or Distributor. Failing to follow and/or altering these installation instructions in either installation or required equipment will void the manufacturer's warranty. Towing behind a non-motorized vehicle will void the warranty.

BX3620
2014-15 Subaru XV Crosstrek
2015 Subaru Impreza
2015-16 Subaru WRX
Installation Instructions

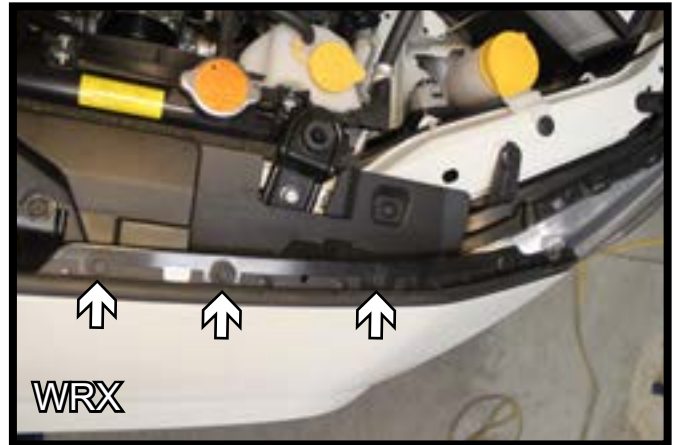

1. Remove the six (6) push pins from the top edge of the fascia. There are three (3) on each side.



2. Release the pin from the top edge of the fascia/wheel well joint by pushing in on the center section. Do this on both sides of the vehicle.

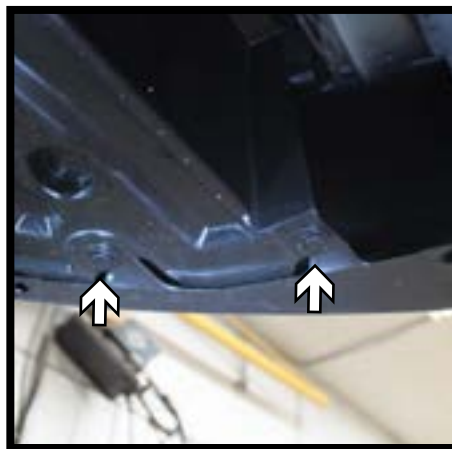
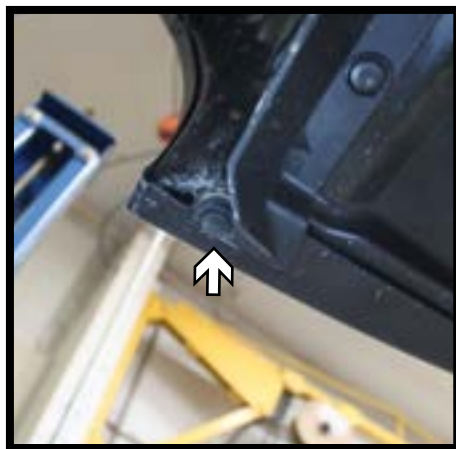

3. **XV/Impreza:** Remove the eight (8) push pins from the underside of the fascia. There are three (3) in each corner and two (2) in the middle.
WRX: Remove the nine (9) push pins from the underside of the fascia. There are three (3) in each corner and three (3) in the middle.

BX3620
2014-15 Subaru XV Crosstrek
2015 Subaru Impreza
2015-16 Subaru WRX
Installation Instructions



4. Unsnap the corners of the fascia from the fender. Remove the fascia from the vehicle, disconnecting any electrical connections and set the fascia aside.

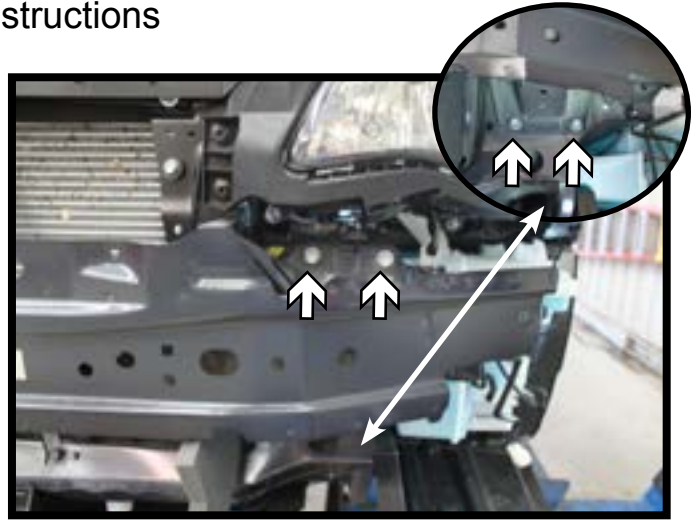

5. Using a 12MM socket, remove the four (4) bolts from the bumper. There are two (2) on the top and bottom of the bumper. Do this on both sides of the vehicle. Set the bumper aside.



6. Using a 10MM socket, remove the screw on the underside of the outer plastic shielding, letting the shield hang loose. Do this on both sides of the vehicle.

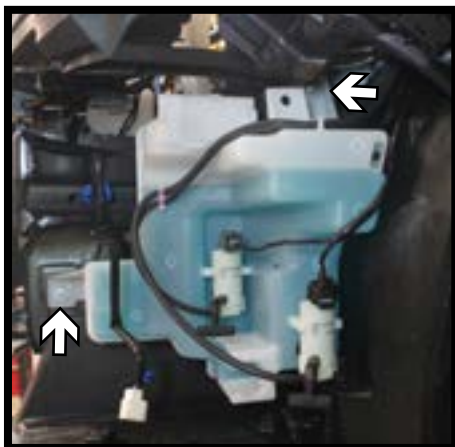

7. Using a 10MM socket, remove the three (3) screws from the washer reservoir. There is one (1) in front, one (1) at the top (left) and one (1) behind the wheel well liner (right). Remove the push pin from the reservoir neck (middle) and disconnect/plug all lines. Set the reservoir aside.

BX3620
2014-15 Subaru XV Crosstrek
2015 Subaru Impreza
2015-16 Subaru WRX
Installation Instructions

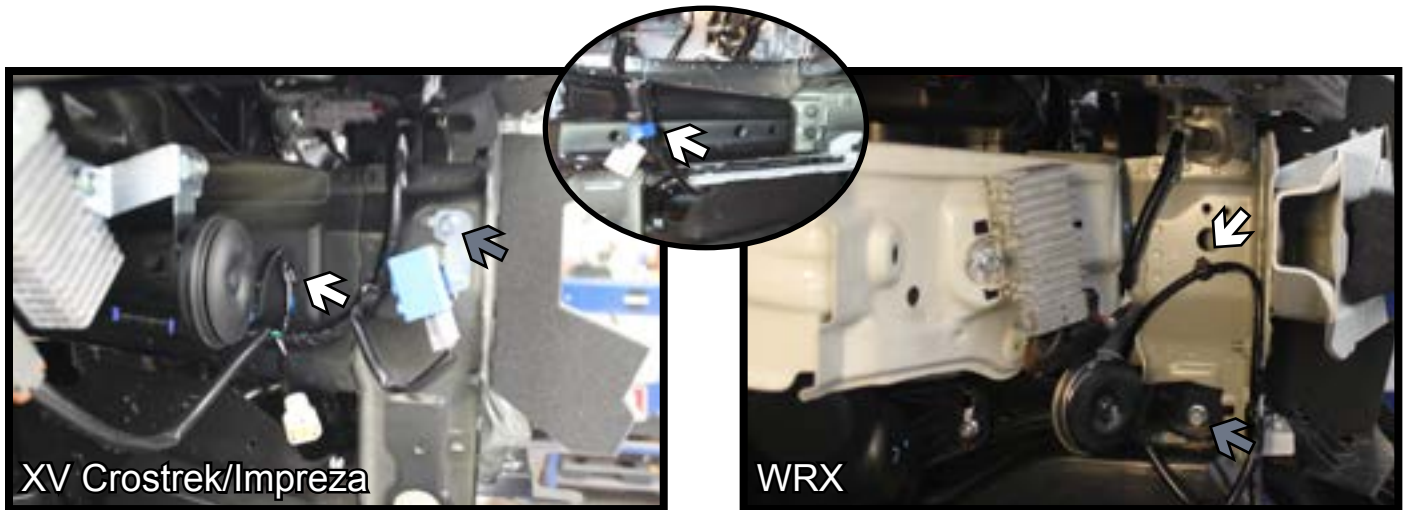

8. **XV/Impreza:** On the passenger side, using a 10MM socket, remove the box from the frame and set aside(gray). Also remove the wire loom from the frame (white).

WRX: On the passenger side, using a 10MM socket, remove the horn from the frame and set aside(gray). Also remove the wire loom from the frame (white).

All Models: On the driver side, unsnap the wire loom from the frame brace (inset).

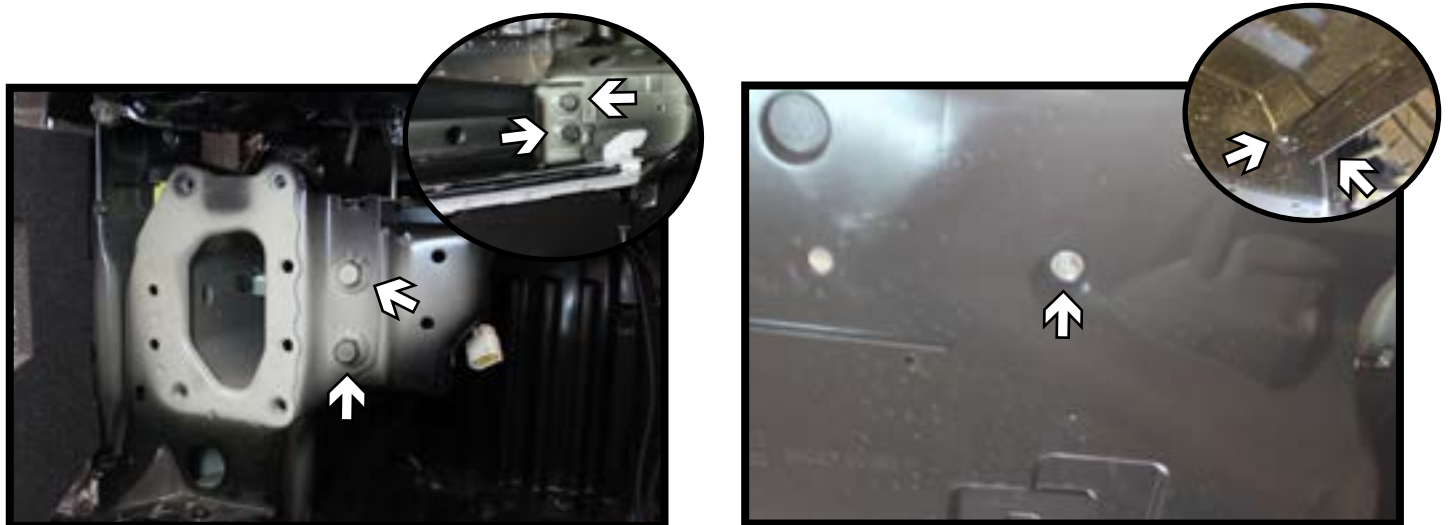

9. On the driver side, using a 14MM socket, remove the four (4) bolts from the frame brace. There are two (2) on in the back and two (2) in front. Set the extension aside.

10. Drop the front of belly pan down for baseplate installation. Using a 12MM socket, remove the two (2) screws from the underneath. Then remove the two (2) push pins from each side (inset). Unsnap the front lip from the brackets.

Note: On WRX models there are two (2) additional push pins to remove in the center of the pan.

BX3620
2014-15 Subaru XV Crosstrek
2015 Subaru Impreza
2015-16 Subaru WRX
Installation Instructions

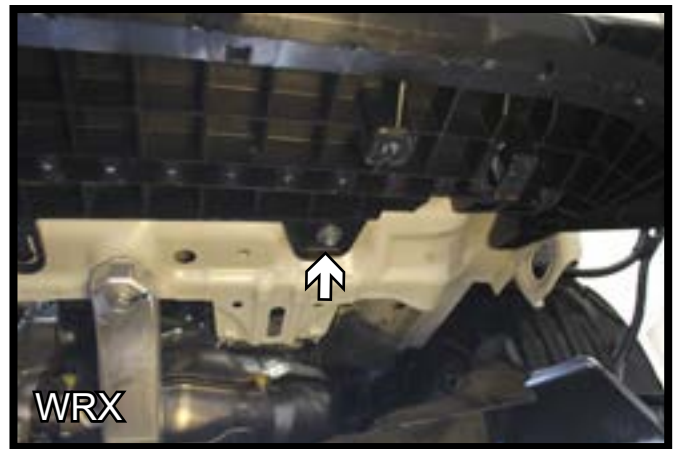

11. **XV/Impreza:** Using a 10MM socket, remove the screw from the belly pan bracket and set aside. Do this on both sides of the vehicle.
WRX: Using a 10MM socket, remove the three (3) screws from the lower shielding and set aside.

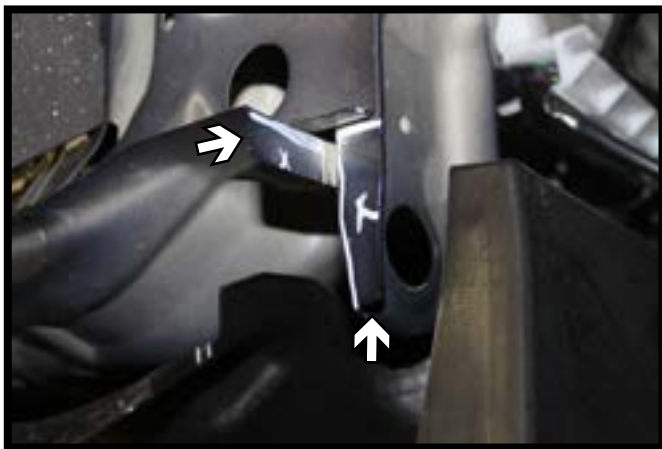

12. Using a reciprocating saw, trim the frame flanges as shown. Do this on both sides of the vehicle.



13. After the two (2) previous flanges are trimmed off. Mark and trim the frame flange as shown. Do this on both sides of the vehicle.

BX3620
2014-15 Subaru XV Crosstrek
2015 Subaru Impreza
2015-16 Subaru WRX
Installation Instructions

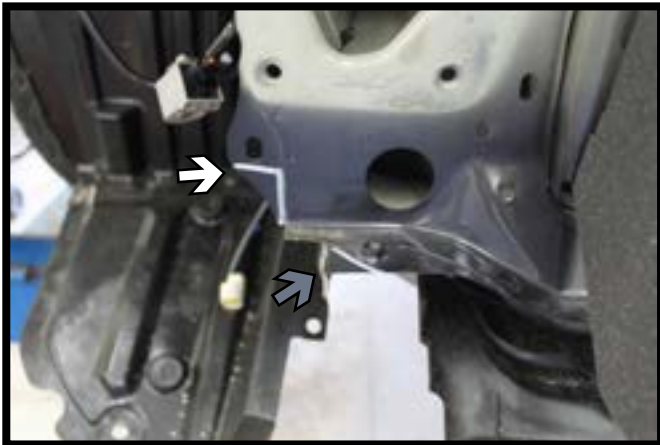

14. Using a reciprocating saw, trim off the corner or bend down (gray). Do this on both sides of the vehicle.

On the passenger side only, trim out a notch in the lower corner of the frame face to allow the baseplate to slide onto the frame (white).

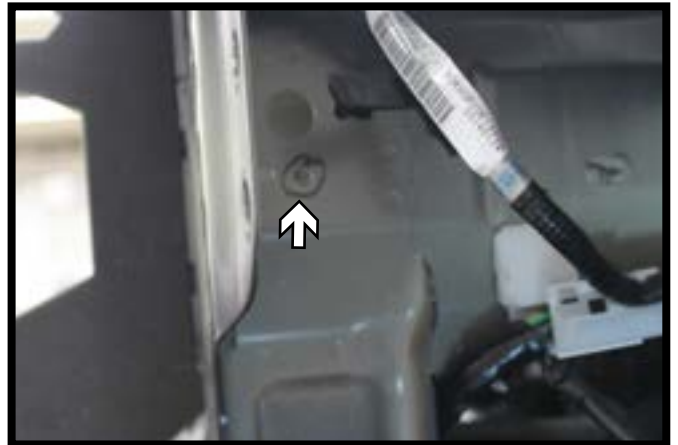

15. Using a 3/8" drill bit, drill out the factory holes on both driver and passenger side.

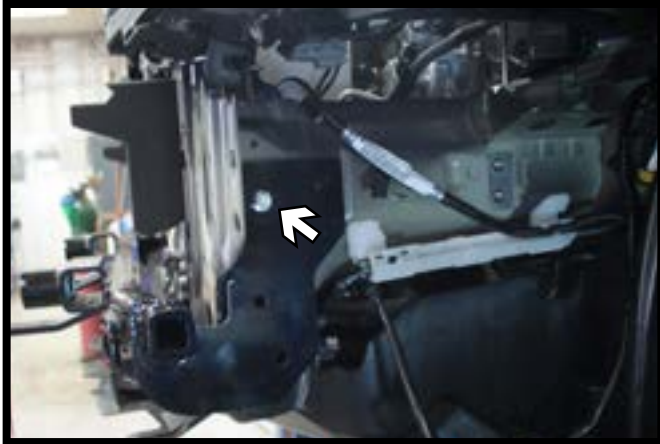

16. Position the baseplate onto the frame. Install a 3/8"-16 x 1-1/2" bolt with 3/8" lock washer into the pre-drilled hole and a 3/8" nut plate on the inside of the frame. Do this on both sides of the vehicle.

Level the baseplate and fully tighten all hardware.

**** Use Loctite® Red on all bolt threads and tighten all bolts to the appropriate torque.**

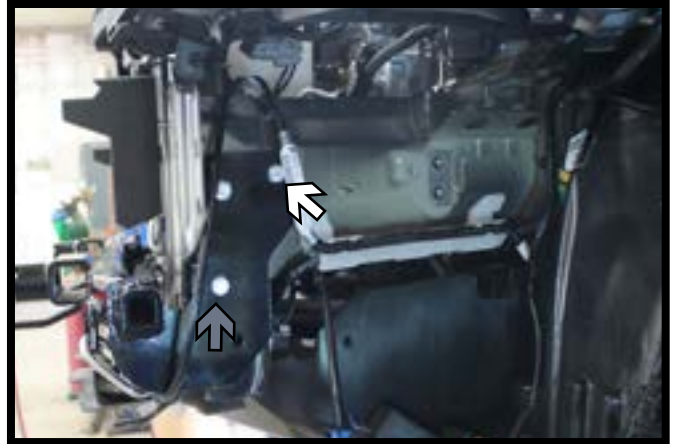

17. Using a 3/8" drill bit, drill the remaining two (2) holes thru the frame. Install 3/8"-16 x 1-1/2" bolt with 3/8" lock washer into the top hole (white) and a 3/8"-16 x 2" bolt with 3/8" lock washer into the bottom hole (gray). Using 3/8" nut plates on the inside of the frame. On the lower hole use the provided spacer tube in between the baseplate and frame. Do this on both sides of the vehicle. Fully tighten all hardware.

**** Use Loctite® Red on all bolt threads and tighten all bolts to the appropriate torque.**

BX3620
2014-15 Subaru XV Crosstrek
2015 Subaru Impreza
2015-16 Subaru WRX
Installation Instructions



18. **XV/Impreza:** On the passenger side, using the supplied self tapping screw, reattached the box to the frame just below the horn.
- WRX:** On the passenger side, attach the horn to the baseplate with the supplied 1/4" hardware.



BX3620
2014-15 Subaru XV Crosstrek
2015 Subaru Impreza
2015-16 Subaru WRX
Installation Instructions



21. **WRX:** Trim the lower shield as needed to clear the baseplate/safety cables. Reinstall to the vehicle.

XV/Impreza: Reinstall the belly pan brackets.



22. **Optional Breakaway:**

Method #1: Using a 12MM socket remove one of factory brace bolts and reinstall with the breakaway bracket (left).

Method #2: Using a 1/4" drill bit, drill a hole in the flange of the bumper at the desired location. Install the breakaway bracket to the bumper with the supplied 1/4" hardware (right). Bend the lower flange up as needed to straighten the bracket.

Install the breakaway to the bracket with the supplied 1/4" hardware.

BX3620
2014-15 Subaru XV Crosstrek
2015 Subaru Impreza
2015-16 Subaru WRX
Installation Instructions



23. Reinstall the washer reservoir, bumper, frame brace and belly pan.

Hold the fascia as close to its original position, mark and trim the fascia around the convenience links and attachment tabs. Reinstall the fascia.

CUSTOMER SERVICE COMMITMENT

Blue Ox® is committed to providing you with exceptional customer care throughout your lifetime with our products. Our team is here to assist you with any questions you may have regarding the performance of your product. Simply call (402) 385-3051 and you can speak with our technical service team.

Additionally, please visit our website to see which rallies our Destination America team will be attending. For a nominal fee, our service technician will service your towing system to ensure it's in proper working condition. Also, as a commitment to our customers, should you visit our factory, you can stay at our full service Blue Ox® campground at no charge along with enjoying a factory tour.

Again, thank you for being our customer and for the confidence you have shown in the performance of our products. It is because of customers like you we enjoy the success we have today.

© 2015 Blue Ox
One Mill Road, Industrial Park
Pender, Nebraska 68047
Phone: (402) 385-3051
Fax: (402) 385-3360
www.blueox.com

General Information

1. Ensure that your product(s) are registered online at www.blueox.com. It is crucial to register your product(s) so that you may be alerted of product offerings, updates, upgrades, maintenance and safety bulletins, and/or recalls.
2. **It is the owner's responsibility to inspect all towing equipment for cracked welds, missing or worn parts and loose bolts before each towing trip.** Be sure to use Loctite® Red on all bolts and tighten to the recommended specifications.
3. **It is the owner's responsibility to hook up all towing equipment per manufacturer's instructions/recommendations.**
4. Remove the attachment tabs when not in use (if applicable).

Notice To Baseplate Installer

1. It is YOUR responsibility to watch for:

- Oil cooler and air conditioner lines
- Electrical wires and hoses
- Missing parts or attaching points on the frame

** If the baseplate is improperly installed and is against a wire or hose, it could cause fluid leaks or electrical shorts some time after the actual baseplate installation.

Permanent Baseplate Safety Cable Installation

Permanent baseplate safety cables are strongly recommended when towing a vehicle with a tow bar. The principle function of the permanent baseplate safety cables is to prevent the towed vehicle from breaking loose in the event the connection between the frame of the towed vehicle and the baseplate fails or becomes disconnected. The cables must be connected from the baseplate to the frame rail or cross member of the vehicle's frame. The illustrations below show the possible arrangements recommended by Blue Ox®. Each permanent baseplate safety cable must have an adequate weight rating for the towing system. The weight rating of the two (2) cables together will not qualify.

Do not mount the permanent baseplate safety cables against wires, hoses or brake lines.

These permanent baseplate safety cables should remain installed as long as the baseplate is installed on the vehicle. Permanent baseplate safety cables are to be used in conjunction with, and NOT a replacement for legally required safety cables attaching the towed vehicle to the towing vehicle.

OPTION #1

Permanent Baseplate Safety Cables to Cross Member or Frame of Towed Vehicle.

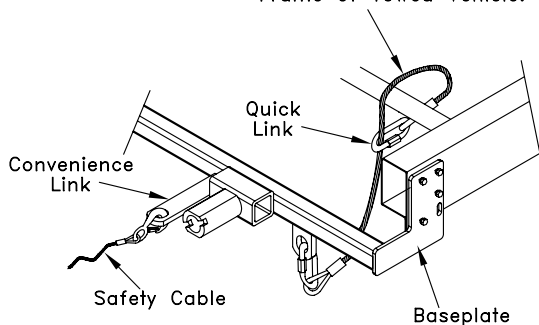

OPTION #2

Permanent Baseplate Safety Cables to Cross Member or Frame of Towed Vehicle.

