

NOTES:

1. ALL WIRES MUST HAVE THE (UL) "UNDERWRITERS LABRATORIES" SYMBOL PRINTED ON THEM
2. MUST HAVE VENDOR ID MARKING SOMEWHERE ON HARNESS
3. HARNESS LENGTH TOLERANCE: +1.00/-1.00 UNLESS OTHERWISE NOTED.
4. ALL LOOM SHOULD BE HIGH TEMPERATURE RATED.
5. CONDUCTORS MUST BE LISTED BY AN RVIA APPROVED AGENCY (UL, CSA...)
6. CONDUCTORS MUST BE MARKED WITH AWG AND AS REQUIRED BY THE LISTING AGENCY

REVISION HISTORY					
REV	DATE	DESCRIPTION	CA	DWR	APVD
A	3/16/2006	RELEASE TO PRODUCTION		HS	JSC
B	11/10/2017	VERIFY HARNESS, UPDATE DESCRIPTION, & FORMAT, ADD NOTES	CA-0096451	MLL	JML

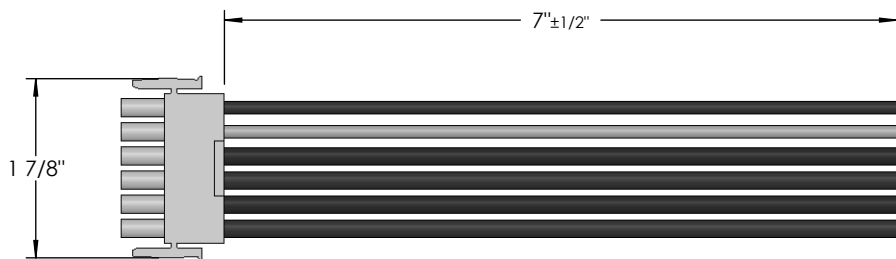
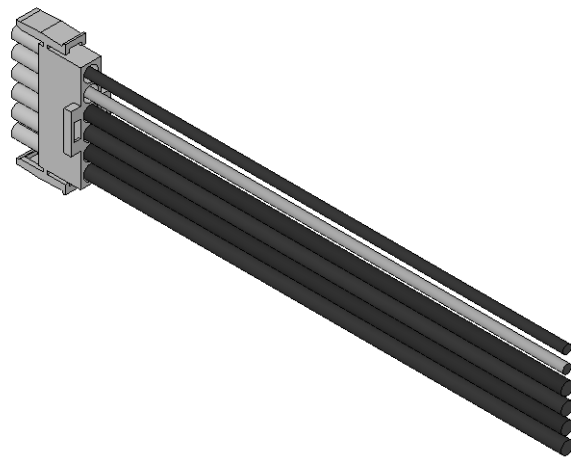

- GREEN 16 GA WIRE
- YELLOW 16 GA WIRE
- BLACK 10 GA WIRE
- RED 10 GA WIRE
- BLACK 10 GA WIRE
- RED 10 GA WIRE

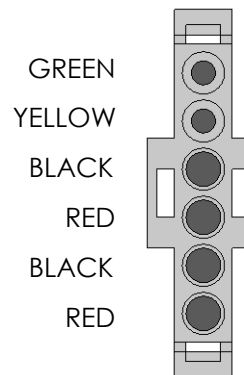

TITLE: ELEC PIGTL HRNS 7 RD MALE

UNLESS OTHERWISE SPECIFIED
 1. ALL DIMENSIONS ARE IN INCHES
 2. BREAK SHARP EDGES & DEBURR
 3. MATERIAL & FINISH TO BE AS NOTED OR SUBSTITUTED WITH AN APPROVED AND TESTED EQUIVALENT

TOLERANCES (EXCEPT AS NOTED)	
DECIMAL	.X ±.1 .XX ±.03 .XXX ±.015
FRACTIONAL	±1/16
ANGULAR	±1°



THE INFORMATION CONTAINED IN THIS DRAWING IS THE SOLE PROPERTY OF LIPPERT COMPONENTS, INC. ANY REPRODUCTION IN PART OR AS A WHOLE WITHOUT THE WRITTEN PERMISSION OF LIPPERT COMPONENTS, INC. IS PROHIBITED.					
DWG. NO. 135696	SIZE A	DATE: 3/16/2006	REV. B		
DRAWN BY HS	CHECKED BY JSC	APPROVED BY	SHEET 1	OF 1	

REFERENCE NUMBER:	L50-109
MATERIAL TYPE:	
SURFACE QUALITY:	
DECIMAL:	
FNSH GOOD WEIGHT:	
BLANK WEIGHT:	0
BLANK SIZE:	6.75 X 0

