

NOTES:

1. USE JIGS 115 & 203
2. WELD OUTSIDE OF CHANNEL ONLY

REVISIONS					
REV.	DATE	DESCRIPTION	CA	DWR	APVD
A	4/25/2007				
B	10/15/2012	UPDATED PRINT, ADDED JIG NOTE		RAW	TG
C	6/24/2017	ADD WELD SYMBOLS AND NOTE(S)	CA-0081416	LDV	JMM

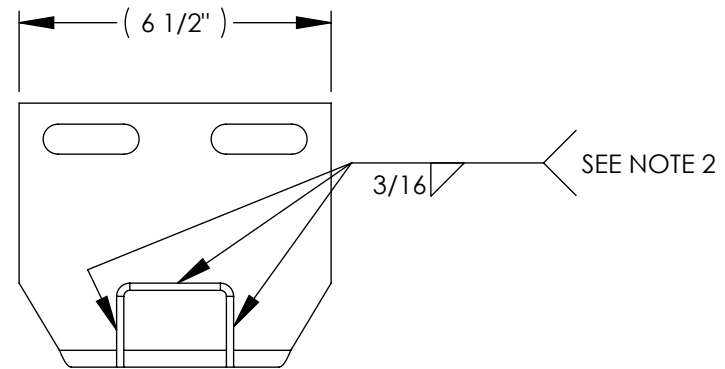
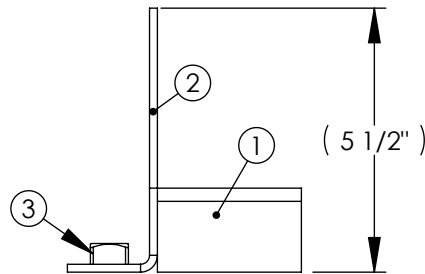
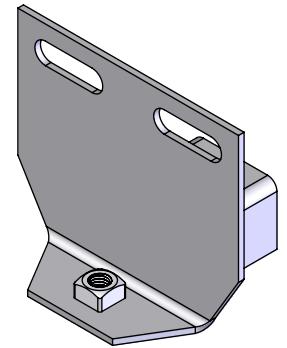
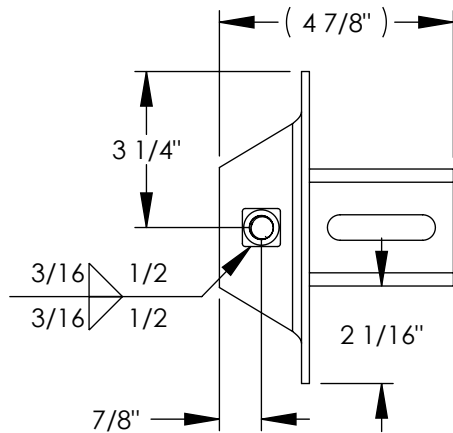

ITEM	PART NO.	CONFIG	DESCRIPTION	NAME	GA	Default
1	159278	Default	XMC 2 7/16" X 1 3/4" X 1 3/4" X 1/8" L3"	XMC	9	1
2	104850	Default	6 1/2" X 5 1/2" X 1 7/8"	ANG	8	1
3	118219	Default	NUT - 1/2 - 13; SQUARE	FASTENER		1

TITLE:

FLUSH ADJUSTABLE HEAD; 2 X 2

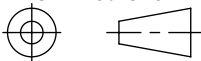
<p><u>UNLESS OTHERWISE SPECIFIED</u> ALL DIMENSIONS ARE IN INCHES BREAK SHARP EDGES & DEBURR</p>		<p>TOLERANCES (EXCEPT AS NOTED)</p> <p>DECIMAL .X ±.1 .XX ±.03 .XXX ±.005</p> <p>FRACTIONAL ±1/16</p> <p>ANGULAR ±1°</p>	<p>LIPPERT COMPONENTS</p>  <p>2703 COLLEGE AVE. GOSHEN, IN 46528</p>	<p>THE INFORMATION CONTAINED IN THIS DRAWING IS THE SOLE PROPERTY OF LIPPERT COMPONENTS, INC. ANY REPRODUCTION IN PART OR AS A WHOLE WITHOUT THE WRITTEN PERMISSION OF LIPPERT COMPONENTS, INC. IS PROHIBITED.</p>		
<p>FILLETS R.015</p>	<p>FINISH 125√</p>	<p>THIRD ANGLE PROJECTION</p> 	<p>DWG. NO.</p> <p>163049</p>	<p>SIZE</p> <p>A</p>	<p>DATE:</p> <p>7/27/2005</p>	<p>REV.</p> <p>C</p>
<p>SCALE:</p> <p>1:4</p>			<p>ENG.</p> <p>RAW</p>	<p>DWN.</p> <p>RAW</p>	<p>SHEET</p> <p>1</p>	<p>OF</p> <p>1</p>