

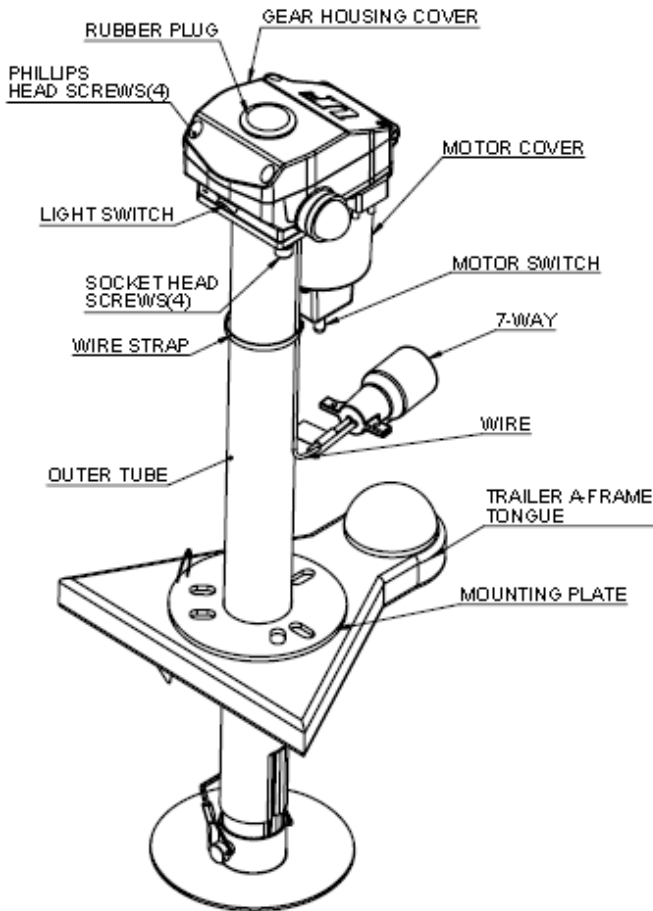

INSTALLATION/OPERATION



APPLICATION

The Ultra 3502-7 Electric Tongue Jack with the 7-Way Connector is a 12-volt motor-driven screw jack for use on travel trailers and boat trailers.

SPECIFICATIONS

Vertical Load: **3500** lbs. continuous over full stroke with 5000 instantaneous tongue breakaway capacity.

Travel – 18"

Power Requirement -12 volt D.C.

Model # 3502 - 2" outer tube w/ 1³/₄" inner tube

Retracted Height - 25¹/₂"

Removable Foot Pad -6" dia.

Approximate Shipping Weight – 22 lbs.

INSTALLATION

1. Block the wheels and support the trailer "A" frame securely.
2. Remove the existing jack.

NOTE: Save the original nuts, bolts, and washers for installing the Ultra 3502-7 Electric Tongue Jack.

3. The Electric Tongue is internally grounded. Therefore, for good electrical contact, clean well where the "A" frame comes in contact with the Tongue Jack Mounting Plate.
4. Install the Electric Tongue Jack using original nuts and bolts and the 3 serrated lock washers supplied with jack. The serrated lock washer is placed under the bolt and on top of the mounting plate.
5. The Electric Tongue Jack was designed to replace an existing crank down jack. The diameter of the outer

tube of your chosen jack, will need to match the existing hole size, or you will need to modify the hole diameter to fit.

6. Depending on user's personal preference, align the motor head so that the motor housing is facing the front of the "A" frame or so the motor housing is facing the driver side of the trailer.

WARNING: DO-NOT use extension wire.

CAUTION: We do not recommend using the flip-up type footpad. Doing so requires the tongue jack to be altered which voids the warranty and can cause the failure of the jack.

OPERATION

1. Block trailer wheels securely.
2. Plug the Tongue Jack 7-Way connector into the 7-way male receptacle on the tow vehicle (after disconnecting your trailer 7-Way connector).
3. The Ultra 3502-7 Electric Tongue Jack is operated by means of the Toggle Switch located under the motor housing.
4. Extend the jack by holding the Toggle Switch in the Extend position.

CAUTION: The motor will stall if jack reaches the full extent of travel both in retract and extend directions. There is an over load protection for the jack to shut off power that will auto reset in 15 seconds. After using jack, operator should learn the travel limit stops. The operator should stop the jack before reaching the travel limit.

5. Retract the jack by holding the Toggle Switch in the Retract position. The jack is now fully retracted.

NOTE: If the motor should stall with the jack in the fully retracted position, and the Toggle Switch is not released, the motor will automatically switch off.

MANUAL OPERATION

1. Disconnect the 7-Way connector from the tow vehicle.
2. Remove plug cap in the access hole. (located top center of the housing cover)
3. Insert the 9/16" deep well socket (included) in the access hole, over the drive spindle tang. Rotate the socket clockwise to retract and counter clockwise extend.
4. When complete, remove socket and replace plug cap.

LUBRICATION

1. The jack is lubricated before leaving the factory. Under normal conditions, lubrication will be needed annually.
2. Grease the Jackscrew by extending the jack until the grease fitting is aligned with the hole in the outer tube. Using a standard grease gun and standard chassis lube, give two pumps.
3. Grease the gears in gearbox.
 - a. Disconnect the 7-Way Connector from the tow vehicle.
 - b. Remove the gear cover via 4 Phillips screws.
 - c. Grease the gears with chassis lube and reinstall cover.

STORAGE

A hook and loop strap has been included to help store the wire/connector to the jack when not in use



MOTOR EXPLODED VIEW

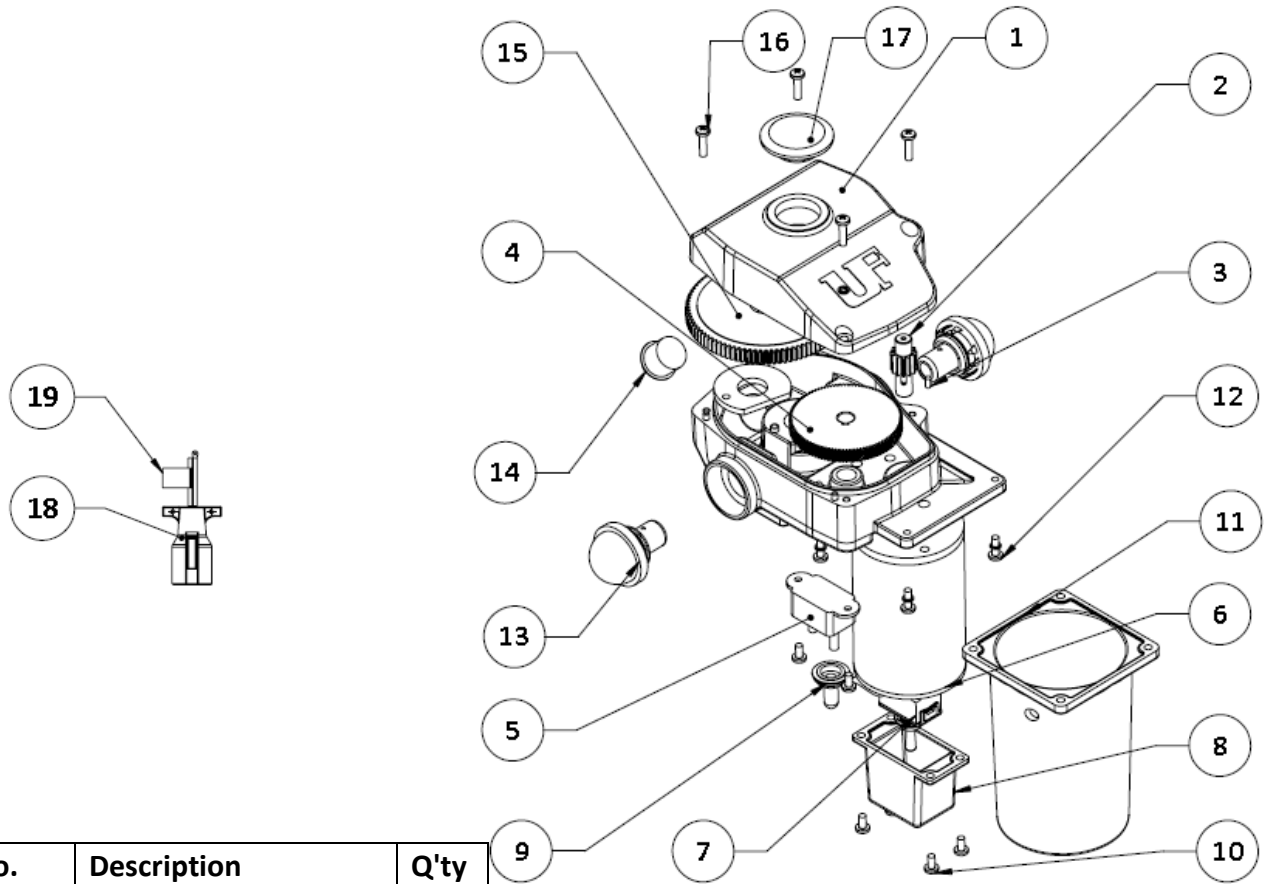

No.	Part No.	Description	Q'ty
1	38-751030	Gear Housing Cover	1
2	38-751124	Pinion Gear 12T	1
3	38-751154	Pinion Key 3x6	1
4	38-751118	Spur Gear	1
5	38-101283	Circuit Breaker	1
6	38-751040	Motor	1
7	38-751037	Motor Switch	1
8	38-751047	Switch Housing	1
9	38-751039	Switch Boot	1
10	38-751060	Screw M4x8	6
11	38-751048	Motor Housing	1
12	38-751010	Screw M4x12	4
13	38-751042	Light	2
14	38-751057	Light Switch	1
15	38-751085	Main Gear	1
16	38-751070	Screw M4x16	4
17	38-751114	Rubber Plug	1
18	38-751090	7-Way Connector Assembly	1
19	38-751091	Strap-Hook/Loop	1

Not Shown	Part No.	Description	Q'ty
	38-751167	Socket 9/16" Deep Well / Manual Override	1



LOWER STEM ASSEMBLY EXPLODED VIEW

No.	Part No.	Description	Q'ty
1	38-752010	2" Outer Tube	1
2(A-F)	38-751160	1.75" Inner Tube Assembly	1
2A	38-751122	Collar Hex Head	1
2B	38-752018	Retaining Pin	1
2C	38-751121	Thrust Bearing	1
2D	38-751138	Cotter Pin	1
2E	38-751127	Upper Pin	1
2F	17-753230	Grease Zerk 6-1.0mm	1
3	38-751100	Footpad Standard 2" (3502)	1
4	38-141023	Wire Lock Pin	1
5	38-114452	Serrated Washer	3

38-751170 – Lower Stem Assembly (Includes #1 & #2)

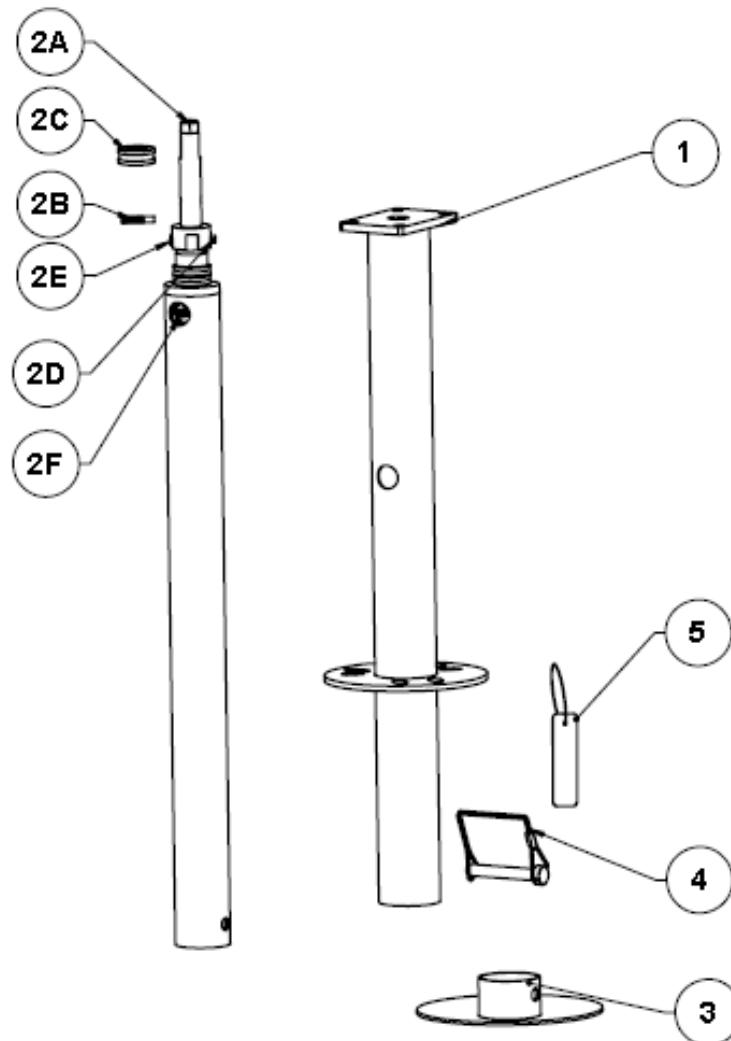



WIRING DIAGRAM

