



BREAK-AWAY INSTALLATION

The Break-Away is an important part of the BrakeBuddy system and is required by law in most states. Do not operate your BrakeBuddy without a properly functioning Break-Away.

Remove all components from the package. Contents (Fig. 1):

- (A) 1, 1/16" coiled break-away cable with one large and one small clip on the ends
- (B) 1 junction box with wiring harness
- (C) 1 strap clamp
- (D) 2 hex socket head capscrews
- (E) 2 flat washers
- (F) 2 lock washers
- (G) 2 sheet metal screws
- (H) 2 grommets
- (I) 5 nylon ties
- (J) 1 loose velcro patch

Installing Junction Box

1. Find a convenient, sturdy place on the front of your towed vehicle to mount the junction box (B). This should be installed on the driver's side of the vehicle if possible.
2. Clean the mounting surface and attach the velcro patch (J) (Fig. 2).
3. Attach the junction box (B) to the velcro patch (J) so the pin with the ring faces forward and the wiring harness feeds back into the engine compartment.
4. Place the mounting bracket (C) over the junction box (B) and mark the hole locations to be drilled and tapped.
5. Remove bracket (C) and junction box (B). Drill marked holes with a 1/8" metal drill bit.

NOTE: For thin sheet metal or plastic, it may be necessary to reinforce the plastic or thin metal to insure the bracket will not separate from the vehicle when the break-away pin is pulled. If you are going to drill through thicker metal, use hex socket head capscrews (D). You will need to drill a hole using a #25 drill bit and tap the hole using a 10-24 tap.

6. Replace the junction box (B) and attach the bracket (C) using hex socket head capscrews (D) or sheet metal screws (G) provided (Fig. 3).

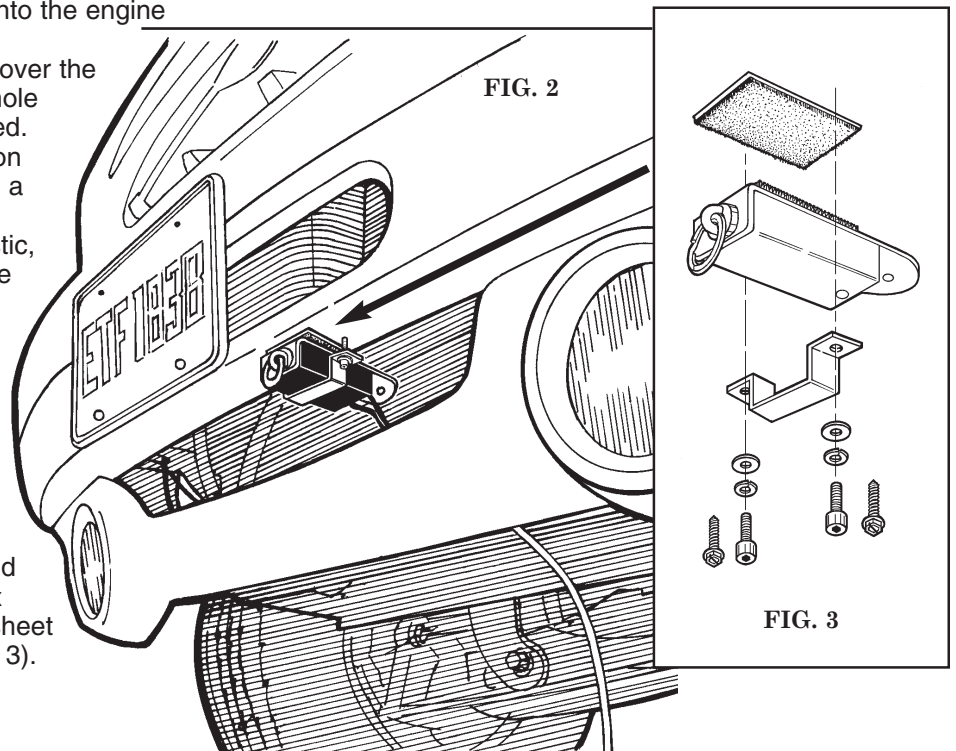
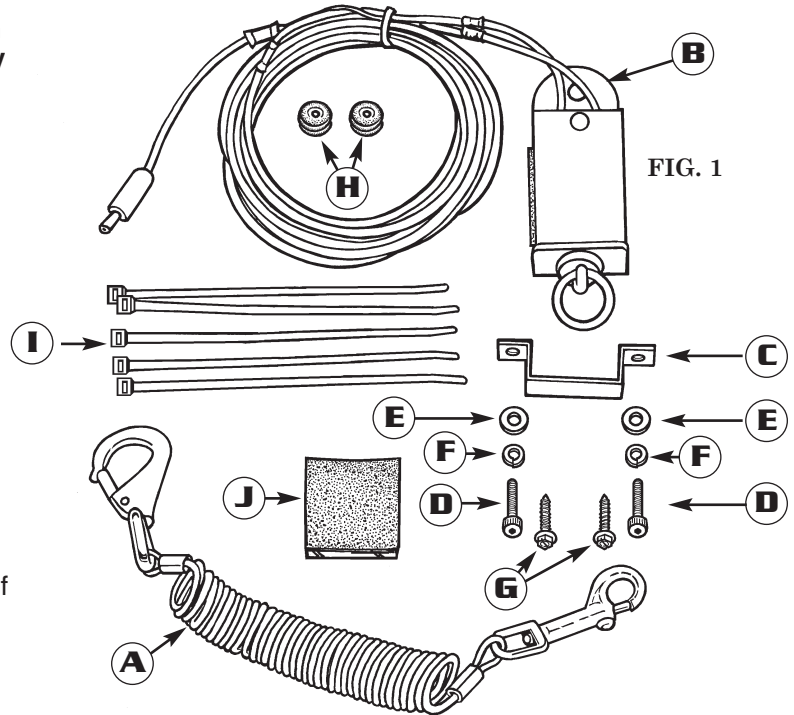

7. Locate a place in the firewall that will allow the wiring harness to be fed through into the passenger compartment of the towed vehicle. Use of an existing hole would be most convenient.
8. If there is no existing hole, drill a 15/32" diameter hole through the firewall (Fig. 4 / **K**). Be careful not to drill into any functional components of the vehicle.
9. Starting from the junction box (Fig. 4 / **B**), route the black electrical wire up to the firewall keeping it away from hot or moving engine components using the nylon ties (**I**) provided (Fig. 4 / **M**).
10. Feed the black wire through the hole in the firewall and into the passenger compartment (Fig. 5).
11. Place the split rubber grommet provided (**H**) over the black electrical wire (Fig. 6) and slide it into the 15/32" hole and fasten it into place (Fig. 7).

NOTE: Failure to properly install the 15/32" rubber grommet may result in harmful fumes entering the vehicle, or damage to the wires.

Using the Break-Away System

After attaching your towed vehicle to your coach and all hook-ups are complete, you will need to attach the break-away cable (**A**) from the junction box (**B**) to the motor home. **DO NOT WRAP THE CABLE AROUND THE TOW BAR.**

1. Attach the small clip on the cable (**A**) to the loop on the pull pin of the junction box (Fig. 8 / **O**), and then attach the large clip to the motor home (Fig. 8 / **P**). The coiled break-away cable fits all applications and needs no adjustment.
2. Install the BrakeBuddy in your towed vehicle and plug the junction box wire harness into the receptacle on top of the BrakeBuddy (Fig. 9 / **Q**).
3. Before the start of every trip, pull the break-away pin to test that the break-away system activates the Brake Buddy.
4. When the use of the towed vehicle is needed, simply unhook the small clip from the loop on the pull pin of the junction box (**B**). Unplug the junction box wire harness from the BrakeBuddy and coil the wire under the dashboard or under your floor mat (Fig. 10).

