

REVISION HISTORY					
REV	DATE	DESCRIPTION	ECN	DWR	APVD
A	5/13/2015	RELEASED TO PRODUCTION	ECN-SP-NP-21136	VJO	
B	10/1/2015	ADD 379111 CARTON	ECN-SP-DE-15738	MLL	DH

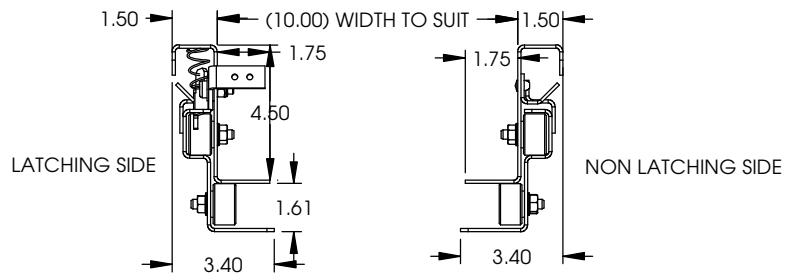
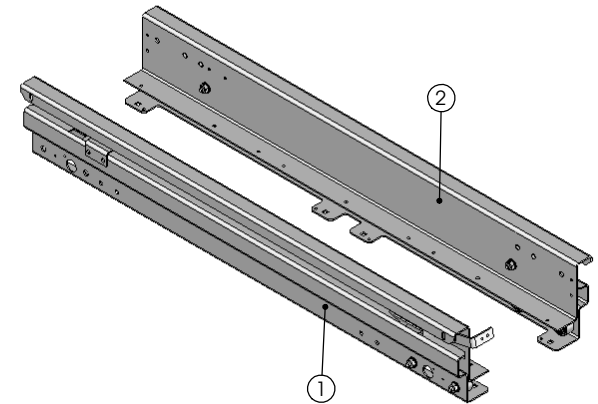
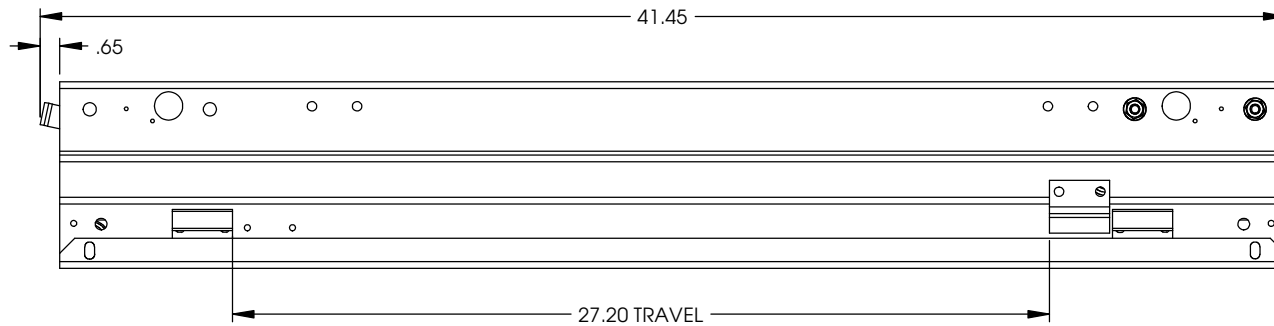

ITEM	PART NO.	CONFIG	DESCRIPTION	NAME	GA	Default
1	378617	Default	ASSY RAIL 42 IN W/ LATCH (4100024)	SUB ASSY		1
2	378647	Default	ASSY RAIL 42 IN W/O LATCH (4100036)	SUB ASSY		1
3	379111	Default	CARTON 48 1/2 X 7 1/4 X 6 (1403775)	CARTON		1

TITLE: SLIDE 42 IN RAILS ONLY (905890000)

UNLESS OTHERWISE SPECIFIED
 1. ALL DIMENSIONS ARE IN INCHES BREAK SHARP EDGES & DEBURR
 2. MATERIAL & FINISH TO BE AS NOTED OR SUBSTITUTED WITH AN APPROVED AND TESTED EQUIVALENT

REFERENCE NUMBER: PG: 905890000	TOLERANCES (EXCEPT AS NOTED)		THE INFORMATION CONTAINED IN THIS DRAWING IS THE SOLE PROPERTY OF LIPPERT COMPONENTS, INC. ANY REPRODUCTION IN PART OR AS A WHOLE WITHOUT THE WRITTEN PERMISSION OF LIPPERT COMPONENTS, INC. IS PROHIBITED.	
MATERIAL TYPE:	DECIMAL .X ±1 .XX ±010 .XXX ±005		DWG. NO. 370782	DATE: 05/15/2015
SURFACE QUALITY:	FILLETS R.015 FINISH 125/√	SIZE B	SCALE: 1:8	
DECIMAL:	THIRD ANGLE PROJECTION	FRACTIONAL ±1/16	DRAWN BY VJO	CHECKED BY VJO
FINISH GOOD WEIGHT: 39.666	ANGULAR ±1°		APPROVED BY	SHEET 1 OF 1
BLANK WEIGHT:				
BLANK SIZE: X				