

Installation and Operation Instructions

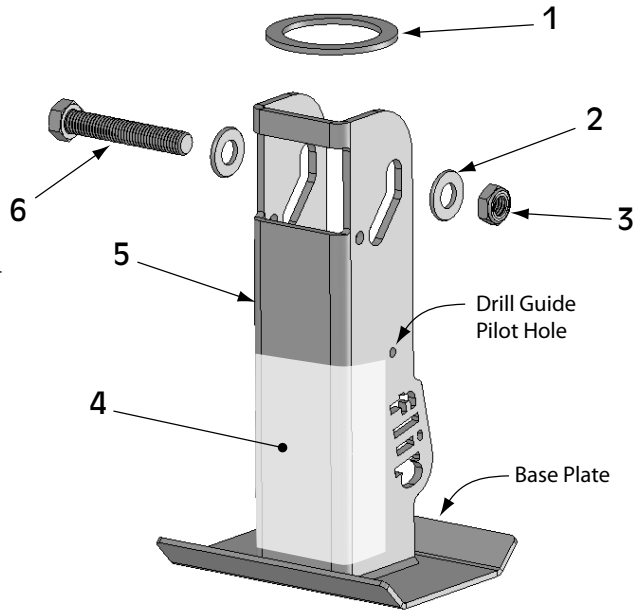

Tools Needed for Installation:

- 3/16" Metal Drill Bit
- 1/2" Metal Drill Bit
- Drill
- Wood Block
- (2) 3/4" wrenches
- Measuring tape
- Pencil or scratch awl
- Center punch

Parts Breakdown

Fig. #	Part #	Description	Qty.
1	88-01-6200	Spacer Ring (2" I.D.)	1
2	90-04-9110	1/2" Washer	2
3	90-04-9285	1/2" Nylock nut	1
4	BD088-WS	Warning Sticker	1
5	88-01-6600	Flip Automatic Jack Foot	1
6	88-01-6150	1/2" x 3" bolt	1

WARNING

- **Read entire instruction manual before using this product. Failure to do so can result in serious injury or death.**
- **Never exceed max 1,400 lb. tongue weight rating.**
- **Do not use to support trailer parked on grade greater than 3% (1.72°).**
- **Chock tires on both sides while supporting trailer with jack foot.**
- **Do not support trailer with jack foot placed on un-level ground or debris. Jack foot base plate must be in complete contact with ground.**
- **Support tongue weight with jack foot in vertical position only when attachment bolt is resting at bottom of guide slot.**
- **Replace worn or faded safety label immediately.**
- **Install only on a 2-1/4" jack with a 2" outside dimension inner jack tube.**

CAUTION

- **Always use adequate personal protective equipment when installing.**
- **Wear safety glasses when installing.**
- **Avoid pinch points between jack extension, spacer ring, jack, and trailer frame when retracting jack.**

Installation Instructions

STEP 1

Locate trailer on a flat level surface, such as a driveway or parking lot. Chock both sides of the trailer, and set tow vehicle parking brake. Keep trailer coupled to tow vehicle, or place jack stands under trailer tongue to support trailer without the use of the tongue jack. Disconnect trailer plug, safety chains, and safety breakaway cable from the tow vehicle and move them out of the way.

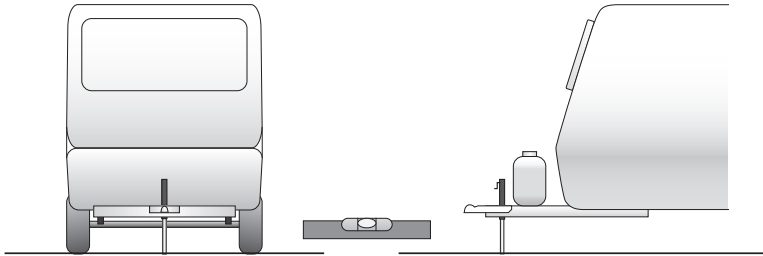

Install Flip™ jack foot with trailer parked on level ground both side-to-side and front-to-back.



Never exceed max 1,400 lb. tongue weight rating.

Install only on a 2-1/4” jack with a 2” outside dimension inner jack tube.

STEP 2

Drill Hole in Jack

Step 2a - Options for Jacks with pre-existing holes in inner-jack tube

Step 2b - Locating hole in square jack

Step 2c - Locating hole in round jack

Step 2a - Options for Jacks with pre-existing holes in inner-jack tube.

Jacks with a pre-drilled holes may interfere with the Flip installation or operation. Please read the following three options before going on to locating the install hole for your Flip jack foot. You may need assistance from your dealership when performing these options.

If your jack does NOT have a pre-existing hole at the bottom of the inner jack tube, skip to Step 2b.



Always wear adequate personal protection equipment while installing.

Wear safety glasses.

Option 1: Drill the hole in the normal location.

There may be very little material between the two holes, if any. This is okay, even if the holes interfere slightly. The Flip will still function normally. It is also okay if the thin bit of material between the holes deforms, or even breaks apart. There will still be sufficient material on the sides to hold the bolt and lift the Flip.

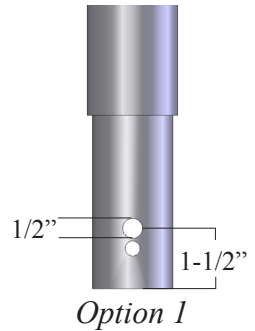

Option 2: Drill a 3/8" instead of 1/2" hole, and use a 3/8" x 3" grade 5 bolt. This will leave more material between the holes. This is a good solution for lower tongue weights. For higher tongue weights, consider option 1 or option 3.



Grade 5 bolts are marked with 3 lines on the head.

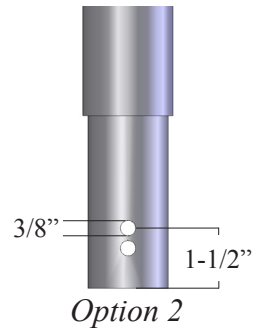

Option 3: The third option, and best solution, is to cut about 1/2" or more off the bottom of the inner tube. Use a pipe cutter if possible, or a cutting wheel or hack saw. Make the bottom as even as possible. Some grinding/filing might be necessary to make a good even bottom edge for the drill guide. By removing about 1/2" from the bottom, the drill guide will then drill the hole with more material in between the two holes. Although more work, this is the best solution.

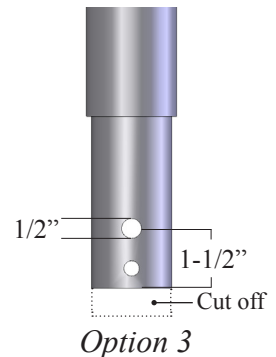

If you have already drilled the hole as in options 1 or 2, but decide you don't like it, you can try option 3. Cut off at least 1/2" or more as needed.

Step 2b - Locating hole in square jack

If you are installing the Flip jack foot on a round jack, skip to [step 2c](#).

If you are installing the Flip jack foot **on a square jack you cannot use the guide holes pre-drilled in the Flip to locate the pilot holes** as you can with a round jack. The hole must be drilled free hand, or by removing the jack from the trailer and using a drill press.

Looking at the driver's side face of the jack, measure up from the bottom of the inner jack tube 1-1/2" and scratch or draw a mark. Then measure 1/2 the distance between the front and back faces of the tube and scratch or draw a line that crosses the first.

This should be at 1" from both the front and back on a 2-1/4" square jack with a 2" inner jack tube.

Repeat this process for the passenger side face of the inner jack tube.

Use a center punch to make a mark at these locations on both sides of the jack.

Drill two 3/16" pilot holes on both sides using these punch marks as a guide to start the hole.

Switch drill bits, and use a 1/2" bit to enlarge both pilot holes. Pass the drill bit completely through the jack to make sure the 1/2" installation bolt will fit smoothly.

Skip to **STEP 3** to continue the Flip installation.

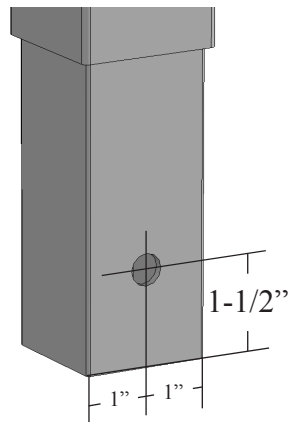

Mark with center punch on both sides. Drill 3/16" pilot hole, then 1/2" install hole.

Step 2c - Locating hole in round jack

Retract the tongue jack far enough that you can fit the wood block and Fastway® Flip™ jack foot under the inner-jack tube. Place the wood block on the ground, and place the jack foot on top, face down with the base plate toward the back of the trailer.

Slowly extend the jack tube until it rests on the jack foot and wood block, and so that the locating plate is pushed up tightly against the front wall of the inner jack tube.

The drill guide holes should be perpendicular to the trailer and jack tube. They should be 1-1/2" from the bottom of the tube, and centered on the tube.

Extend the jack until the weight resting on the Flip jack foot holds it securely in place so that it will not move while the guide holes are being drilled.

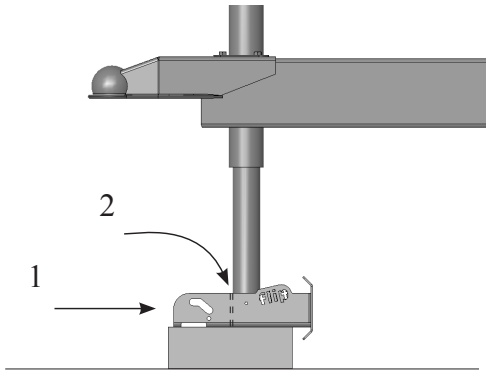

Push jack foot backward(1) so that inner jack tube is tight to locating plate(2).

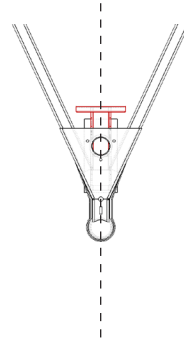

Make sure jack foot is placed parallel to the trailer before drilling guide holes.

Use the 3/16" bit and drill a pilot hole on each side of the jack tube using the drill guide pilot holes on both sides of the jack foot as guides. Retract the jack to a comfortable drilling height, and remove the Flip jack foot and the wood block.

Use the 1/2" drill bit to enlarge a pilot hole. Once the tube wall has been penetrated, ream out the hole slightly to de-burr it and open it up. Switch sides,

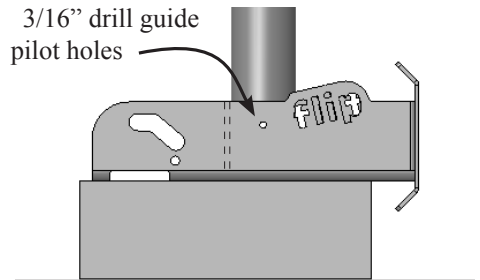

Use drill guide pilot hole to drill 3/16" pilot holes on each side of inner jack tube.

and drill and ream the second hole. Pass the drill bit all the way through the inner jack tube to make sure there is a clean path for the bolt all the way through the tube.

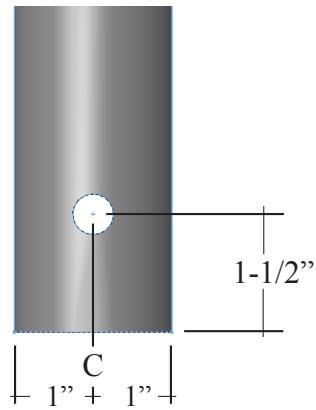

Enlarge with 1/2" drill bit.

STEP 3

If drilling the holes leaves a burr or lip, use a file or grinder to smooth the edge so that the pivoting operation of the Flip jack foot is not disrupted.

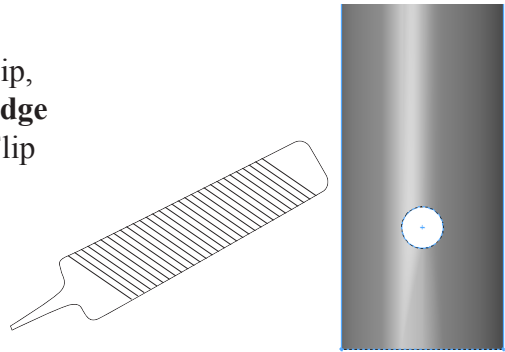

STEP 4

On a round jack the spacer ring must be in place or the jack foot will not 'flip' up completely. A square jack does not need a spacer ring for the Flip jack foot to operate correctly.

Slide the spacer ring up the inner jack tube and hold it up while you position the jack foot to bolt it on. Position the jack foot around the inner jack tube so that the slot at the top lines up with the 1/2" holes just drilled in the jack tube. You may need to retract the jack.

Slide a 1/2" washer onto the 1/2" bolt, and slide the bolt through the slots in the jack foot and holes in the jack tube. Slide the 1/2" washer onto the other end of the bolt, and thread on the Nylock nut. Tighten the nut securely, and then loosen

it only to the point that the Flip jack foot can pivot freely up and down, but not enough that it is sloppy or that there is too much play between the jack foot and the inner jack tube. If the jack foot does not drop smoothly into place, this nut may need to be loosened slightly.

A small amount of lubricant helps the Flip rotate more freely. Do not use petroleum based grease. Use a wax-based bicycle chain lubricant or a spray-on, silicone-based lubricant that naturally repels dust and dirt. Apply lubricant to any surface area that rubs against another during Flip foot operation, such as the top and bottom of the 2" ring, top of the Flip foot, and inner edges of the bolt-guide slot. Wipe off any excess.

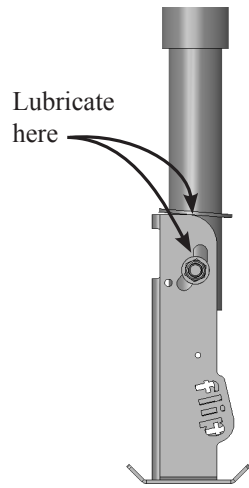

Finished assembly of Flip jack foot on round jack.

NOTE: If your jack does not retract far enough to make the Flip automatic jack foot rotate up completely, or if there is an obstruction below the frame that keeps the jack foot from rotating completely, **you may add additional rings** to take up that space.

Additional rings are available from your dealership, or directly from Fastway® at: www.FastwayTrailer.com.

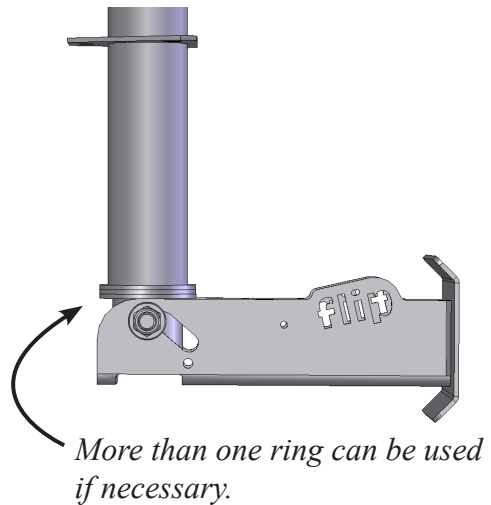

Instructions for Use



Do not use to support trailer parked on grade greater than 3% (1.72°).

Do not support trailer with jack foot resting on un-level ground or debris.

Jack foot base plate must be in complete contact with ground.

STEP 5

When uncoupling your trailer:

Make sure that the trailer is parked on relatively level ground. Most improved campsites, such as those found in private and public campgrounds are fine. Pay special attention to the site when dry camping to make sure the slope is not more than a 3% grade (1.72°) either side-to-side or front-to-back.

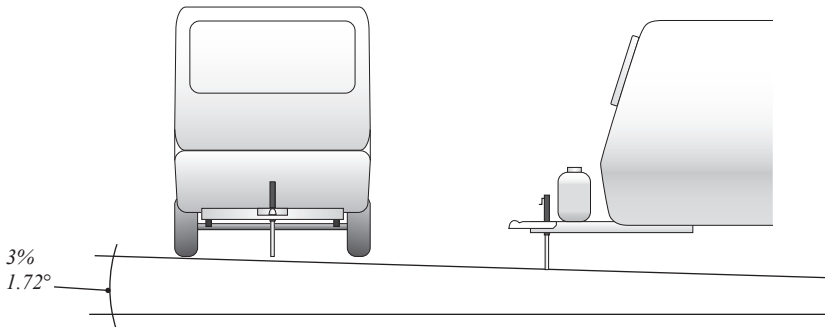

Do not use Flip with trailer parked on a slope steeper than a 3% grade, or 1.72 degrees.

Also make sure that the spot where the jack foot will rest is as level as possible, and free from debris like sticks or stones that might keep the jack foot from being completely supported.

Chock the wheels on both sides of the trailer securely. Disconnect trailer plug, safety chains, and breakaway cable from the tow vehicle. Uncouple the coupler, and extend the jack to raise the coupler off the ball.

If using a weight distributing hitch, you may use the jack foot to raise both the tow vehicle and trailer to make it easier to disconnect the hitch. Once the spring arms are disengaged, lower the trailer and tow vehicle back to a point where the tow vehicle is supporting all of the trailer's tongue weight. Uncouple the coupler, and extend the jack to raise the coupler off the ball.



Support tongue weight with jack foot in vertical position only when attachment bolt is resting at bottom of guide slot.

STEP 6

The Flip jack foot is designed to straighten automatically as more weight is applied. At times it may be helpful to move it forward slightly with your foot to make sure it sits directly below the jack so that the jack tube rests correctly at the bottom of the bolt slot, and against the front of the jack foot or on top of the support/locating plate.

If the full tongue weight is placed on the jack with the jack foot out of position, the inner jack tube can bend, resulting in improper function of the jack or jack foot. It may also damage the jack foot or trailer.

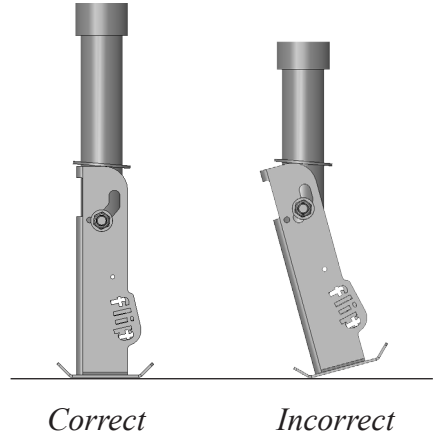

STEP 7

If you must drop the trailer in a place where there is not enough clearance below the jack for the Flip jack foot to pivot down properly, the jack may be extended with the jack foot in a horizontal position. A small block of wood placed directly under the inner jack tube will help keep the weight from bending the Flip jack foot.

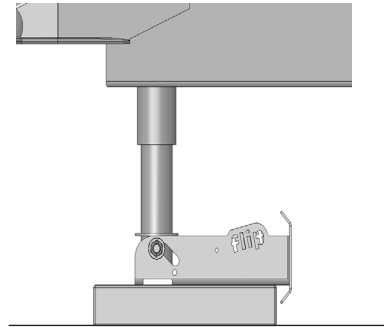

Low ground clearance option.

STEP 8

To couple your trailer:

Back the hitch ball under the coupler. Retract the tongue jack until the coupler rests on the hitch ball. Lock the coupler. If you are using a weight distributing hitch, extend the jack and tension the weight distribution bars.

Retract the jack completely until the flip rotates up and out of the way for towing. Do not force the jack handle after the jack has reached the top of travel. Rotate it back slightly if necessary for towing.

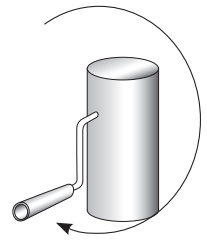
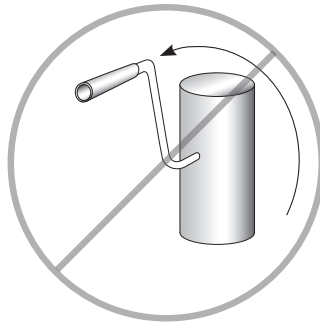

Don't force jack. Rotate back slightly if necessary.

Limited One Year Warranty

Progress Mfg. Inc. warrants, to the original purchaser, this product against defects in materials and workmanship for a period of one year from date of purchase. This warranty does not cover damage due to normal wear and tear, misuse, neglect, abuse, or product finish. Progress Mfg. Inc. reserves the right to repair or replace the defective part(s) at their discretion. Replacement of product or refund constitutes the fulfillment of all liabilities of Progress Mfg. Inc. under this warranty. For questions about warranty coverage and warranty authorization, please call (877) 523-9103. If warranty repair or replacement is approved, send the entire product and proof of purchase, shipping pre-paid, to: Progress Mfg. Inc., 533 South 500 West, Provo, UT 84601

A Product of Progress Mfg. Inc.

Other Great Fastway Products!

The Fastway® Zip™ breakaway cable's coiled design keeps your cable from dragging!

Zip™
Trailer Breakaway
Cable & Switch



Fastest and easiest tandem axle wheel chock ever!

ONEstep™
tandem axle wheel chock

Easy as...

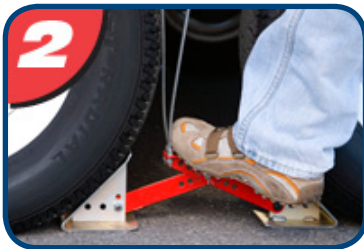
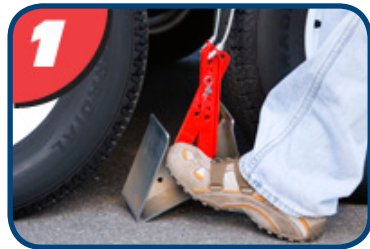

Fastway® Trailer Products
533 South 500 West, Provo, UT 84601
(877) 523-9103
www.FastwayTrailer.com

© 2009 Copyright Progress Mfg. Inc., All rights reserved.

FLIN_0610

All products patent pending.