



**OVER 35 YEARS OF INNOVATION, QUALITY, SAFETY.  
IMPORTANT OWNER-OPERATOR INSTALLATION INSTRUCTIONS**

**C3206A**



**REVISED Version 7 BY: JL 05/6/2015  
TECH SUPPORT (800) 246-8132**

**AFTER INSTALL, PLEASE GIVE  
THIS BOOKLET TO YOUR CUSTOMER**

# Warnings

## Truck Bed and Camper Protection

Torklift **does not** recommend installing your camper on top of a plastic bed liner (or other compressible material such as foam). These materials can act as a spring, causing increased vertical truck camper movement independent of the vehicle. Plastic bed liners can slide on the truck bed surface, and the truck camper can slide on top of the bed liner. Using a plastic bed liner or similar compressible material will void your warranty and may additionally cause truck bed and/or camper damage.



Minor movement or settling can occur in some incidental harsh driving conditions (on or off-road). A rubber bed mat is recommended to protect the truck bed and camper, but is not a requirement to maintain the Torklift legendary lifetime warranty.

## Suspension

To significantly reduce body roll, sag and sway Torklift strongly recommends the StableLoad. Torklift International StableLoads improve safety, handling, and to help level your truck. More information can be found at ([www.Torklift.com/stableload](http://www.Torklift.com/stableload)).

If your truck is additionally equipped with suspension air bags Torklift cautions against over pressurization as this may lead to unsafe vehicle handling characteristics. We have found that airbags used in conjunction with StableLoads have allowed operators to lower air bag pressure by 50% or more. Only pressurize suspension air bags enough to level the truck.

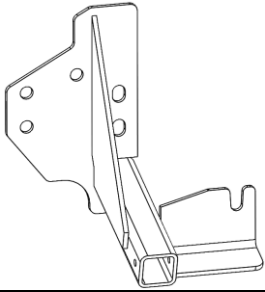
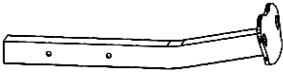
# Included Parts

	<p>Tie Down Receiver</p>	<p><b>2</b></p>
	<p>Bent Tie Down Insert</p>	<p><b>2</b></p>
	<p>M12-1.75x35mm Hex Bolt</p>	<p><b>4</b></p>
	<p>Finishing Kit (Talon Only)</p>	<p><b>1</b></p>

**Installation Notes:** *C3206, C3206A fits a large year range of Chevy and GMC trucks. Several frame photos are provided in step 1 of these instructions for clarification on which factory fasteners need to be removed.*

## Step 1:

Beginning on the driver side of the vehicle, remove the nuts and bolt plate (see photo 1.1) attaching the bumper bracket **(if installed)** to the side of

the frame (18mm). Additionally, remove the hex bolt installed in the frame just forward and above the bumper bracket (**long bed only**). Next remove the nut from the bolt holding the leaf spring shackle to the leaf spring hanger bracket (21mm). Leave the leaf spring hex bolt in place. Set all hardware aside for now. Reference the annotated photos 1.1 to 1.5 below depending on your vehicle.



Leaf Spring Bolt

Additional Frame Hex Bolt

Bumper Bracket Bolts

**Photo 1.2 (Factory Hardware)**

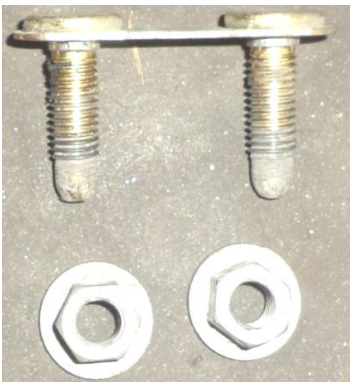

**Photo 1.3 (Receiver Mounting Holes)**

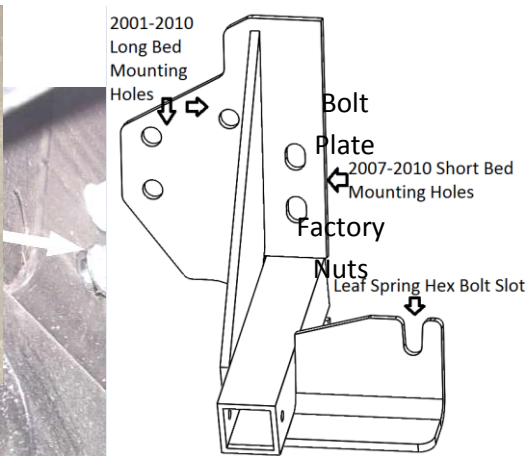

**Photo**

**Photo 1.5 (2007-2010 Short Bed)**



**Step 2:**

Swing the bumper bracket (**if applicable**) away from the frame. It may be necessary to loosen the nuts holding the bumper bracket to the bumper. Lift the **Tie Down Receiver** upwards between the vehicle frame and bumper bracket. Make sure that the leaf spring hanger bolt protrudes through the slot in the **Tie Down Receiver**. Loosely install the frame hex bolt that was removed in step one to hold the tie down receiver in place, as shown Photos 2.1 & 2.2 below. Alternately, use one of the supplied **M12-1.75 x 35mm** hex bolts on 2007-2010 short bed applications.

**Photo 2.1**



**Photo 2.2**

Loosely reinstall the factory hex bolt through the hole in the tie down receiver as pictured.

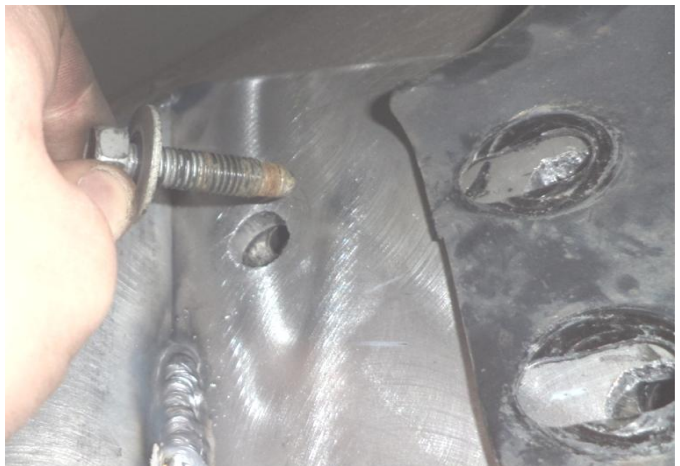

**Step 3:**

Reattach the bumper bracket to the frame over the **Tie Down Receiver**. Replace the factory bolt plate with the two **M12-1.75x35mm** hex bolts provided in the kit (Photo 3.1). Depending on your vehicle, it may be necessary to use a screwdriver or similar tool to align the slotted holes in the bumper bracket with those in the **Tie Down Receiver** and vehicle frame (Photo 3.2). Reinstall the factory nuts hand tight as shown (Photo 3.3).

**Photo 3.1**



**Photo 3.2**

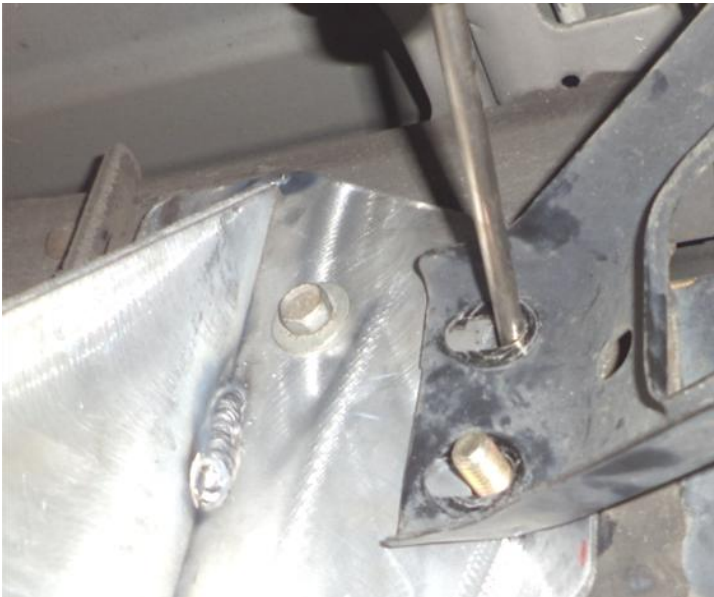

**Photo 3.3**



**Step 4:**

Push the **Tie Down Receiver** upwards until the protruding spring perch bolt is fully seated at the bottom of the slot in the **Tie Down Receiver**. Reinstall the factory nut and leave hand tight for now.

**Note:** It is strongly recommended that a thread locking compound such as “Blue Loctite” is used when reinstalling this factory fastener.

**Photo 4.1**

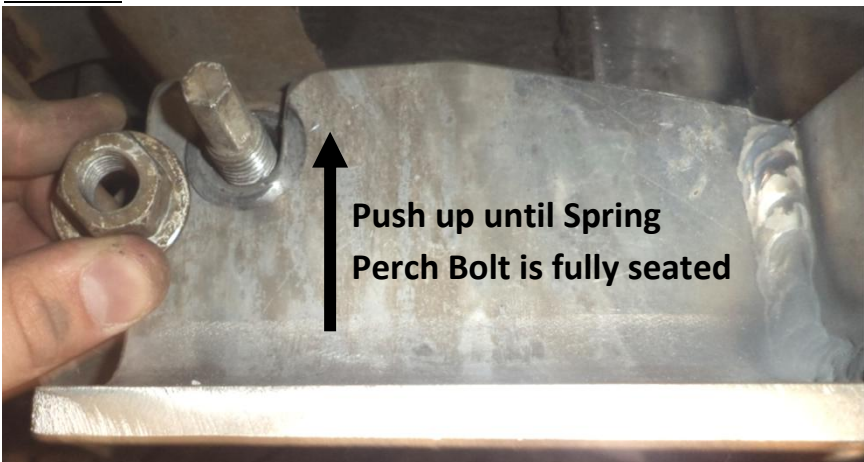



**Step 5:**

With all of the factory hardware installed hand tight, it is time to secure the **Tie Down Receiver** to the frame. Torque the two factory nuts of the bumper bracket to **60 ft-lbs**. It may be necessary to use a wrench on the inside of the frame to prevent the supplied **M12-1.75x35mm hex bolts** from spinning. Next, tighten the frame hex bolt to **25 ft-lbs**. Finally, torque the 21mm hex nut on the spring perch bolt to **90 ft-lbs**. The finished **Tie Down Receiver** should look like photos 5.1 & 5.2 below.

**Photo 5.1**



**Photo 5.2**



**Step 6:**

Install the **Tie Down Insert** into the **Tie Down Receiver**. The Plate at the end of the **Tie Down Insert** should be offset towards the rear of the vehicle. Secure the **Tie Down Insert** with a **Tie Down Lock**.

**Step 7:**

Repeat Steps 1-5 on the passenger side of the vehicle.

## TD Finishing Kit

	1-3/4" x 1-3/4" X 2" Foam Backing Plug	2
	2" x 2" x 1-1/2" Receiver Cap	2

### Step 1

Insert one **1-3/4" x 1-3/4" x 2" Foam Backing Plug** into the back of the **Aluminum Tie Down Receiver** opening. If the back of the receiver is inaccessible, insert the Foam Backing Plug in the front of the **Aluminum Tie Down Receiver** and press it back with the **Tie Down Insert** see Photo 1.1

### Photo 1.1

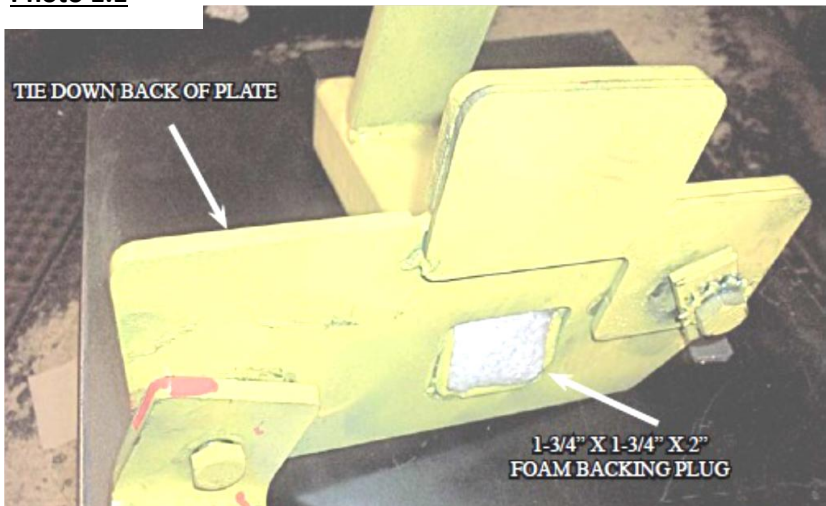

## Step 2

Insert one **2" x 2" x 1-1/2" Receiver Cap** over the end of the **Aluminum Tie Down Receiver**. See Photo 2.1 (if the 2" x 2" x 1-1/2" Receiver Cap does not fit over the receiver, you will need to notch it out using a box knife or similar) See Photo 2.2.

**PHOTO 2.1**



**PHOTO 2.2**



## **RECOMMENDED TRUCK CAMPER INSTALLATION INSTRUCTIONS**

When securing any heavy load (especially a camper) in your truck bed, your front tie down points should pull the load forward as much as possible. Some camper anchor points may differ with different manufacturers, as well as the camper jack mounting locations. Your Torklift tie down inserts have offset triangular brackets to increase the angle of pull. These are designed to be used in the front facing forward, and the rear facing rearward but can be used in either front or rear. These recommendations are to be considered and followed as a basic rule of thumb . Obviously there will be some applications where this may not be possible. At a minimum, if opposite pull of both front and rear Tiedowns cannot be achieved for whatever reason, you should have at least a forward pull at the front or rear location. If your camper does not come with Rubber Bumpers on the front lower portion of the camper, installing Rubber Bumpers (Torklift has Rubber Bumpers available Part A7001) or using a block of wood such as a 2 x 4 in the bed, will prevent the camper from damaging the front bulk head of the truck bed. Minor movement (or settling) can occur in some incidental harsh driving conditions (on or off road). A rubber bed mat is not a requirement to maintain the lifetime warranty on a Torklift system, but a strong recommendation simply as a safety precaution to protect the truck bed, the bottom of the camper and to give the camper additional support.

**TORKLIFT DOES NOT RECOMMEND:** Installing your truck camper in your truck on top of a drop in plastic bed liner!!! The drop in plastic bed liners can slide on top of the truck bed surface, and the camper can slide on top of the slick surface of the bed liner. The liner can also act as a spring causing a trampoline effect increasing vertical truck camper movement, independent of the vehicle, possibly resulting in truck bed, and camper damage!

## **INSTRUCTIONS FOR FINISH MAINTENANCE OF TORKLIFT PRODUCTS**

### **POWDER COATED STEEL:**

To keep your Torklift products looking good follow these guidelines. All steel powder coated Torklift products are sandblasted for maximum adhesion and use a high quality industrial urethane based powder coat. Due to the extreme, harsh, undercar environment that your Torklift products live in, (consistently sprayed with corrosive road chemicals such as salt, and road debris), Torklift does not warranty the power coated finish.

To minimize corrosion from these factors on powder coated steel products, Torklift recommends regularly cleaning and inspecting the powder coated surface and touching up any affected areas with an enamel or urethane based aerosol paint product. If there are any areas of surface rust, there are also aerosol spray rust converters available on the market that can be used as a preparation to touch-up paint application. These finish maintenance products are available at any automotive parts supplier.

### **POLISHED STAINLESS STEEL :**

TorkLift utilizes quality grade 304 stainless steel in our stainless steel polished products. 304 stainless steel is well known for its anti-corrosive properties. However, in some environments such as coastal regions or when coming in contact with some road chemicals, corrosion may occur. For a quick clean simply use WD40 and a cloth rag. We also recommend occasional polishing of our polished stainless products to maintain their attractive finish. Use an approved stainless steel chrome or aluminum mag wheel polish cleaning product which can be purchased from any automotive parts supplier.

# **Torklift International Limited Lifetime Warranty Information**

**322 Railroad Ave North, Kent, WA 98032**

Torklift will require proof of purchase to register, with pictures of any defective product before issuing a replacement. Torklift will not register any product without proof of purchase, which can be faxed, scanned, emailed, or mailed to the information provided below.

Torklift warrants it's hitches, custom hitch receivers, frame mounted tie downs, turnbuckles, and accessories (excluding wire harnesses which carry a 90 day warranty) from date of purchase against defects in material and workmanship under normal use and service for the ownership life of the original consumer purchaser. **ALL COMMERCIAL APPLICATIONS ARE WARRANTED FOR A PERIOD OF 90 DAYS FROM THE DATE OF INSTALLATION/SERVICE.**

Torklift will replace **FREE OF CHARGE** any part which proves defective in material or workmanship when presented to Torklift, **TRANSPORTATION CHARGES PREPAID** by purchaser, at the address above. **THIS WARRANTY IS LIMITED TO DEFECTIVE PARTS REPLACEMENT ONLY. LABOR CHARGES AND/OR DAMAGE INCURRED IN INSTALLATION OR REPLACEMENT, AS WELL AS INCIDENTAL AND CONSEQUENTIAL DAMAGES CONNECTED THEREWITH ARE EXCLUDED.**

This warranty does not include the finish or paint on our products. Rusting, cracking or peeling of the finish is also excluded. Some states do not allow the exclusion or limitation of incidental or consequential damages, so the above limitation or exclusion may not apply to you. Any damage to Torklift products as a result of misuse, abuse, neglect, accident, improper installation or any use violative of

instructions furnished by Torklift or **WHEN USED IN ANY COMMERCIAL APPLICATION WILL VOID THE WARRANTY.**

This warranty gives you specific legal rights, and you may also have rights which vary from state to state. With warranty service, you may be able to go to a small claims court, a state court or a federal district court.

**322 Railroad Ave North, Kent, WA 98032**  
**Phone (800) 246-8132 Fax (253) 854-8003**  
**Or visit our website: [www.TorkLift.com](http://www.TorkLift.com)**

Dear Valued Customer,

Thank you for making TorkLift your choice for truck, camper packages and accessories for your vehicle. By choosing TorkLift products, you have chosen a company that has been serving the RV industry for nearly 40 years and whose name has become synonymous with strength, quality and advanced design and installation.

Please take a few moments of your time to complete the Product Registration Warranty Card on the next page. When registering your newly purchased TorkLift products, you can be assured that your contact information is secure and that you and your product are getting the attention and respect that you deserve.

Thank you again for choosing TorkLift quality products.

**Register for your lifetime warranty and receive a free Torklift International gift.**

To Fax: Send copies of the questionnaire, warranty card and receipt to  
253-854-8003

To E-mail: Send copies of the questionnaire, warranty card and receipt to  
[warranty@torklift.com](mailto:warranty@torklift.com)

To Mail: Send to Torklift International **322 Railroad Ave North, Kent,  
WA 98032**



## OFFICIAL WARRANTY REGISTRATION CARD

PLEASE FILL OUT THIS FORM COMPLETELY AND RETURN TO TORKLIFT WITHIN

30 DAYS OF PURCHASE ACCOMPANIED BY A COPY OF YOUR ORIGINAL RECEIPT

### 1. PART(S) PURCHASED

TODAY'S DATE: \_\_\_\_\_

PART#: \_\_\_\_\_ PART#: \_\_\_\_\_

PART#: \_\_\_\_\_ PART#: \_\_\_\_\_

PART#: \_\_\_\_\_ PART#: \_\_\_\_\_

### 2. PURCHASER INFORMATION

NAME: \_\_\_\_\_

ADDRESS: \_\_\_\_\_

CITY: \_\_\_\_\_ STATE: \_\_\_\_\_ ZIP / POSTAL CODE: \_\_\_\_\_

PHONE: (\_\_\_\_) \_\_\_\_\_ - \_\_\_\_\_ EMAIL: \_\_\_\_\_

### 3. TRUCK INFORMATION

YEAR: \_\_\_\_\_ MAKE: \_\_\_\_\_

MODEL: \_\_\_\_\_ BED LENGTH: \_\_\_\_\_

### 4. CAMPER INFORMATION

YEAR: \_\_\_\_\_ MAKE: \_\_\_\_\_ MODEL: \_\_\_\_\_

### 5. DEALER INFORMATION

PURCHASED FROM: \_\_\_\_\_

ADDRESS: \_\_\_\_\_

CITY: \_\_\_\_\_ STATE: \_\_\_\_\_ ZIP / POSTAL: \_\_\_\_\_

INSTALLED BY: \_\_\_\_\_ OWNER \_\_\_\_\_ ABOVE DEALER \_\_\_\_\_ ANOTHER DEALER \_\_\_\_\_

IF ANOTHER DEALER, WHO: \_\_\_\_\_