

CRE/3000 Suspension System Owner's Manual

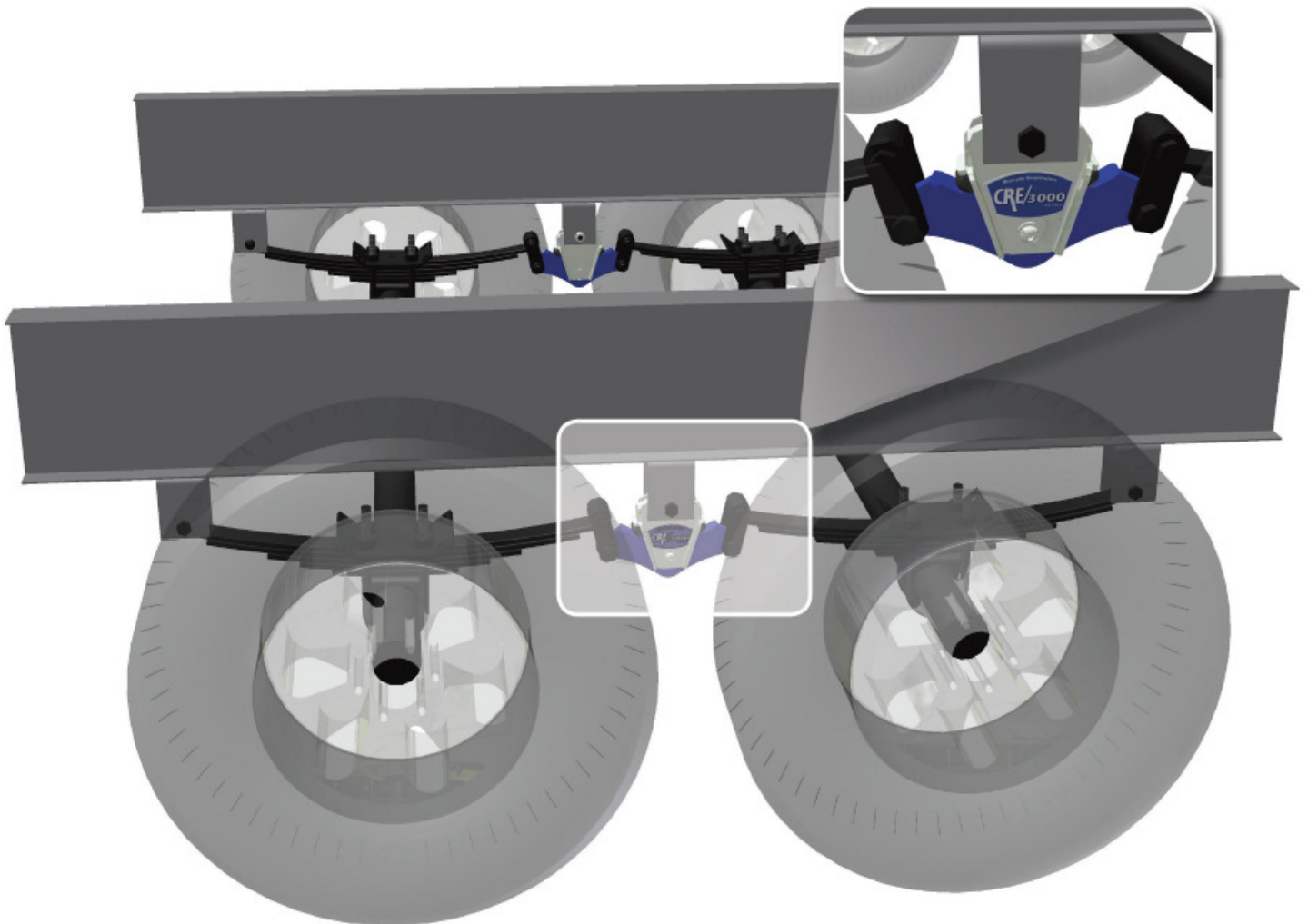

CRE/3000 Suspension System

Contents

Introduction.....	2
Parts Listing.....	3
Triple Axle Setup.....	4
Rubber Spring Inspection.....	5
Basic Troubleshooting.....	6

Introduction

Your recreational vehicle has been equipped with the MOR/ryde CRE/3000 Suspension System. The MOR/ryde system is located between the tandem axles on your trailer, replacing the steel equalizer (see diagram below). This system is uniquely engineered to work in concert with your steel leaf spring suspension to improve overall suspension performance.

At the heart of your MOR/ryde system are MOR/ryde's rubber springs that have been a mainstay in the recreational vehicle market for over 40 years. This new system has been engineered specifically for your trailer using the rubber springs' ability to isolate and absorb road shock and increase your trailer's overall dynamic axle travel. The combination of the MOR/ryde rubber equalizer working in concert with your trailer's leaf springs will greatly enhance your suspension system's ability to deal with today's rough roads. This means you will experience:

- **Smoother towing than with a conventional equalizer and leaf springs**
- **Better protection of your trailer from damaging road shock**

This manual will outline basic troubleshooting and check procedures for your MOR/ryde Suspension System. Service manuals and instructions will be provided with replacement parts in the unlikely event that service is required.

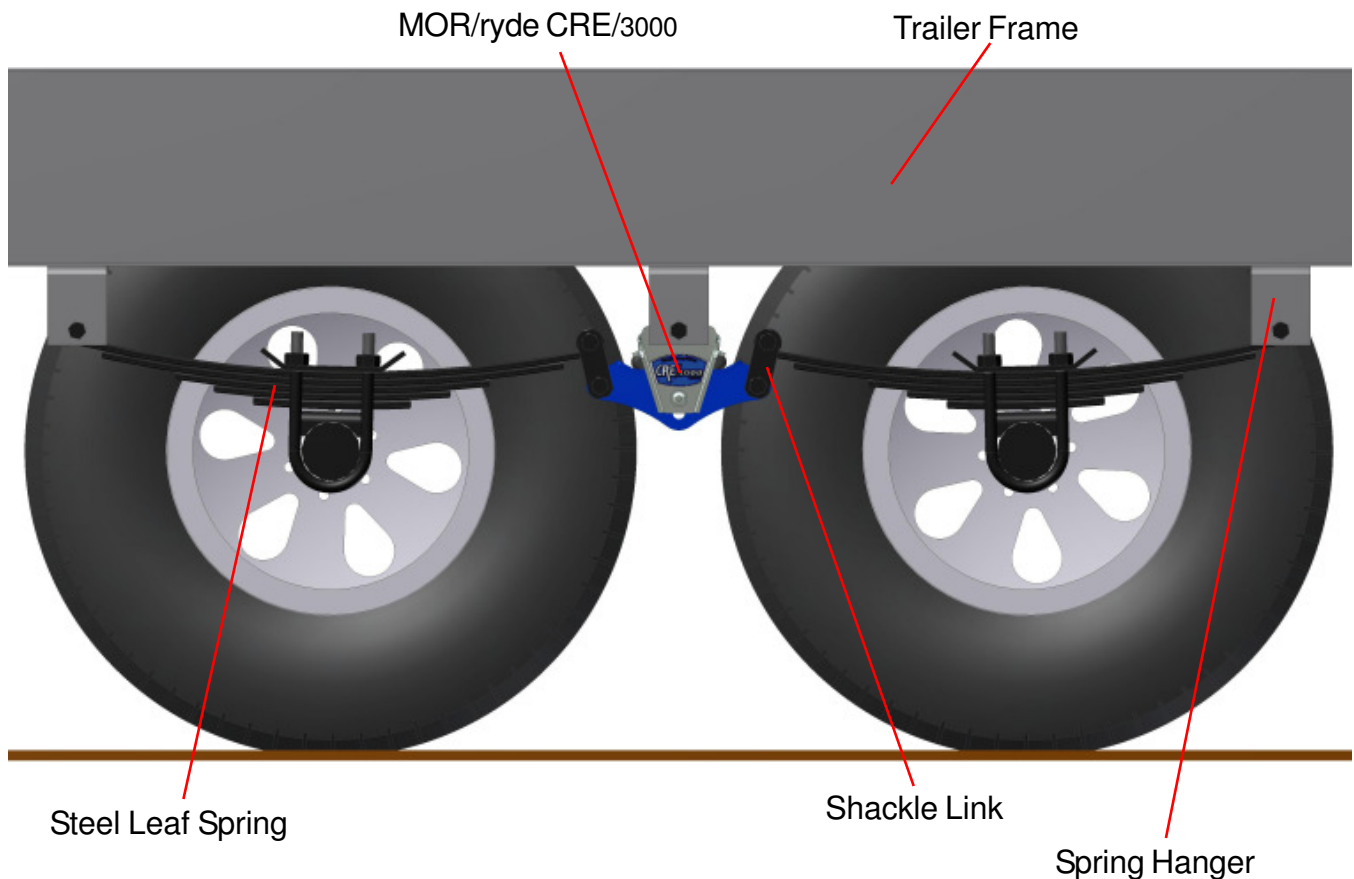

Parts Listing

Parts List		
Item	Qty	Description
1	1	Beam Arm
2	1	Rubber Spring
3	1	Spring Carrier
4	2	Plastic Spacer
5	3	Bronze Bushing
6	1	3/8-16 x 1-1/2" Hardened Coupler Nut
7	2	5/16" Washer
8	1	3/8-16 x 3/4" Button Head
9	1	3/8-16 x 3/4" Hex Head

Note: Quantities shown are per equalizer assembly.

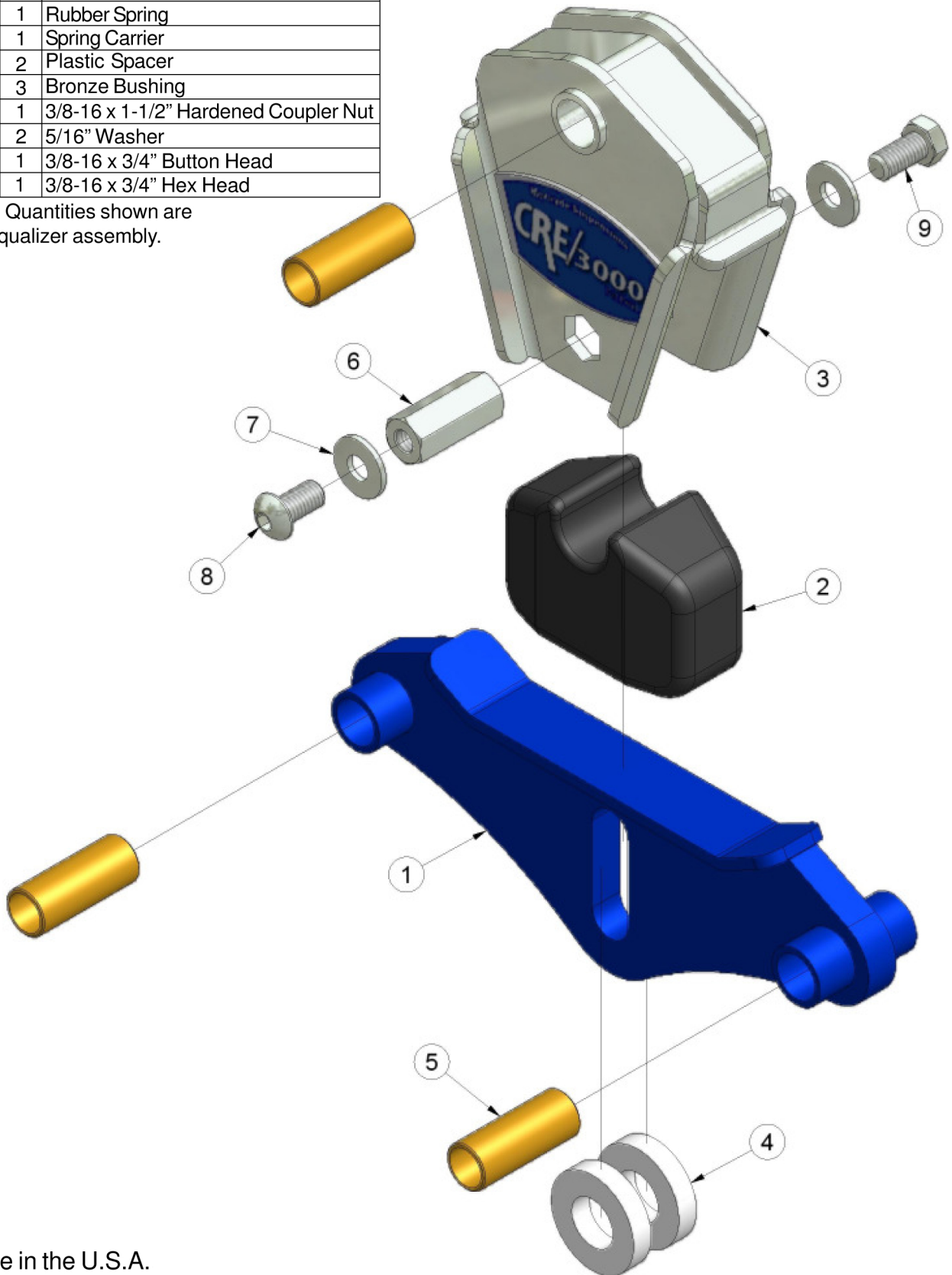

Made in the U.S.A.

Triple Axle Setup

The CRE assembly that has the Control Beam Arm ALWAYS gets installed between the front axle and the center axle.

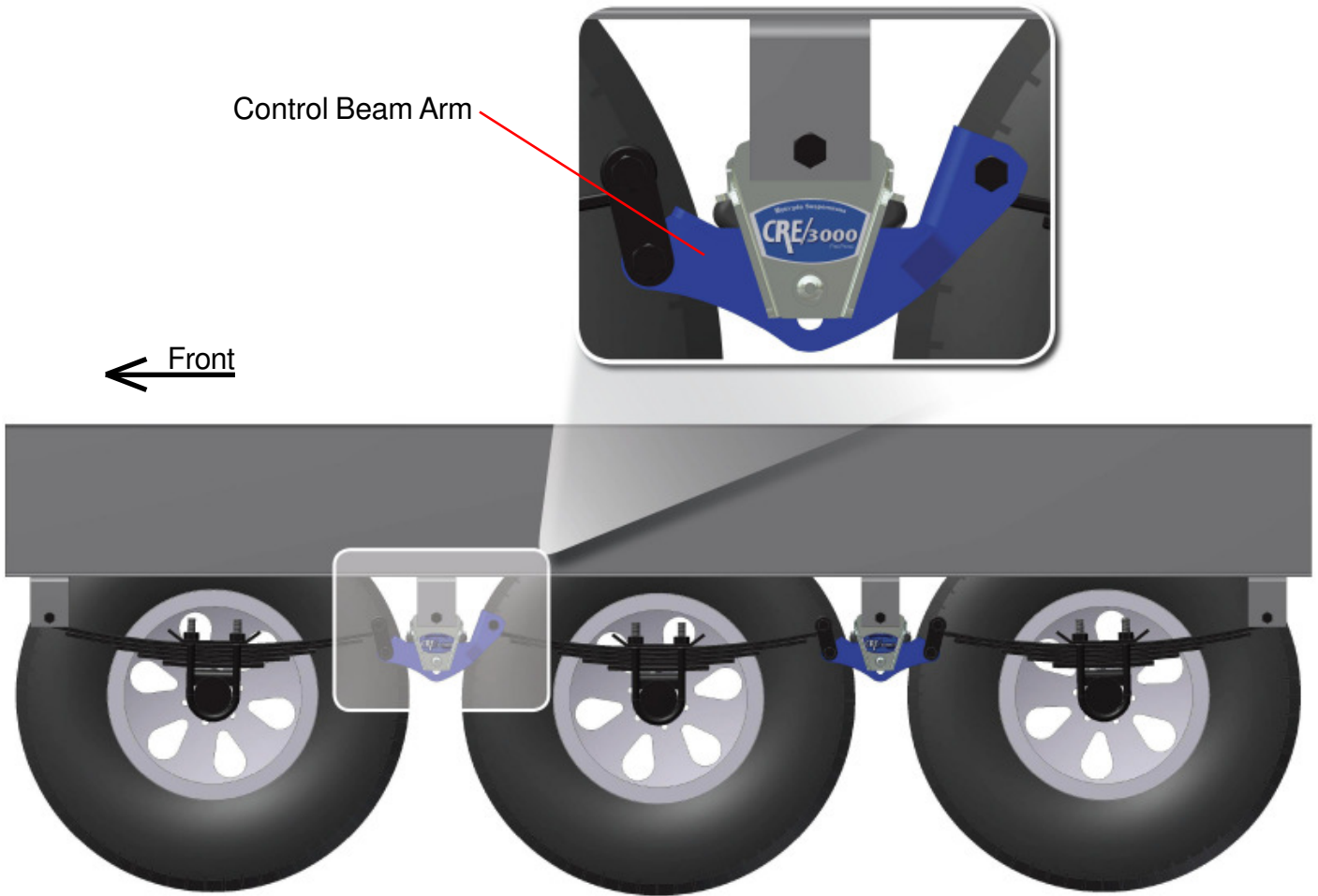

Additional Parts List		
Item	Qty	Description
10	1	Control Beam Arm

Note: Quantities shown are per equalizer assembly.

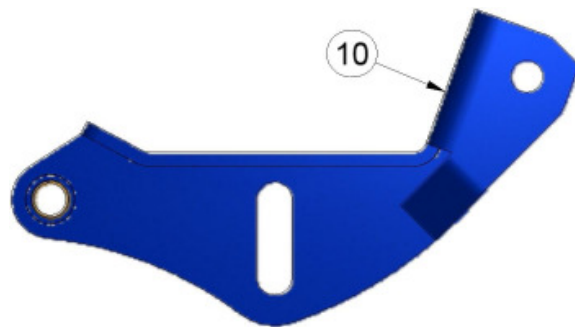

Rubber Spring Inspection

The rubber springs (Item #2 in Parts Listing) should be periodically inspected for deterioration. Figure 1 shows a rubber spring in good condition. If the Tabs that protrude from either side of the Spring Carrier (Item #3 in Parts Listing) are touching the top of the Beam Arm (Item #1 in Parts Listing or Item #10 in Additional Parts List) as shown below (Fig. 2), the spring rate of the spring has been affected and should be replaced. *Note: It is normal to see rubber spring weather checking, which is small surface cracks in the rubber. Weather checking does not require a rubber spring to be replaced. It is also common to see minor tearing or fretting of the rubber around the edges.*

FIG. 1



CRE/3000 with rubber spring in good condition shown at design load.

FIG. 2



CRE/3000 with rubber spring worn out shown at design load.

Note: Tabs must touch on BOTH sides of beam arm for rubber to be worn out.

Basic Troubleshooting

Problem/Symptom	Cause	Correction
Excessive Tire Wear	Axle alignment.	Align axles.
	Improper tire pressure.	Adjust air pressure.*
	Tires out of balance.	Balance tires.
	Improper brake adjustment.	Adjust brakes.
Rough Ride	Torn rubber spring.	Replace rubber spring.
	Trailer is not level front to back.	Adjust pin box height to level out trailer.
	Broken or cracked leaf spring.	Replace leaf spring.
Excessive Sway	Improper tire pressure.	Adjust air pressure.*
	Torn rubber spring.	Replace rubber spring.
	Improper hitch weight.	Travel trailers should have 10%-12% hitch weight. 5th wheel trailers should have 20%-25% hitch weight.

*According to tire manufacturer specifications, proper tire pressure means inflating tires according to individual wheel weights (as long as a wheel is not overloaded), not necessarily inflating to the maximum pressure as specified on the tire.

**If a problem occurs that is not addressed here, please contact MOR/ryde International direct for further service information at 574-293-1581.

MOR/ryde CRE/3000 Suspension System Limited Warranty

Summary of Warranty

We, MOR/ryde, Inc., 1966 Moyer Avenue, P.O. Box 579, Elkhart, Indiana 46515 ("MOR/ryde"), warrant to you, the original first purchaser of new MOR/ryde rubber suspension system ("Product"), for a period of three (3) years from the date of original first purchase ("Warranty Period"), that the Product is free of defects in material or workmanship under normal use and service and will meet or exceed all of our advertised written specifications, excepting items and uses excluded from this Warranty. For a copy of the complete MOR/ryde Warranty please call, write, or email us using the correspondence information listed below.

PLEASE DIRECT ALL CORRESPONDENCE TO:

**MOR/ryde International
P.O. Box 579
Elkhart, IN 46515
Phone: (574) 293-1581
Fax: (574) 294-4936
www.morryde.com
Email: service@morryde.com**

