



TRUE FRAME MOUNTED CAMPER TIE DOWNS

IMPORTANT OWNER-OPERATOR INSTALLATION INSTRUCTIONS

F2014/FMTPJ06FDSC6.5

FRONT TIE DOWNS

APPLICATION FITS

2006-2012 FORD F150 FLEETSIDE

6.5' BED - ALL CABS

CHAIN AND CLEVIS REMOVED ON 07.21.2011

Minor movement (or settling) can occur in some incidental harsh driving conditions
(on or off road).

A rubber bed mat is not a requirement to maintain the lifetime warranty on a Torklift system, but a strong recommendation, simply as a safety precaution to protect the truck bed, the bottom of the camper and to give the camper additional support.

Warning!!

TORKLIFT DOES NOT RECOMMEND: Installing your truck camper in your truck on top of a drop in plastic bed liner!!! THIS WILL VOID YOUR WARRANTY!

The drop in plastic bed liners can slide on top of the truck bed surface, and the camper can slide on top of the slick surface of the bed liner. The liner can also act as a spring causing a trampoline effect increasing vertical truck camper movement, independent of the vehicle, possibly resulting in truck bed damage and/or camper damage!



REVISED vers1 BY: MWP 07/19/2012

TECH SUPPORT (800) 246-8132

**AFTER INSTALL, PLEASE GIVE
THIS BOOKLET TO YOUR CUSTOMER**

F2014 PARTS INVENTORY

2 - FRAME MOUNT RECEIVER	2 - BENT TIE DOWN INSERTS (18")
2 - 1/4" PINS	4 - 1/2" X 2" GRD5 HEX BOLTS
4 - 1/2" GRD5 NUT	4 - 1/2" STAR WASHERS
1 - 1/2" BOLT FISHER	4 - 1/2" LOCK WASHERS
4 - 1 X 2 PLATE WASHERS	4 - 1/2" FLAT WASHERS
1 - GUSSET REINFORCEMENT PLATE	2 - 7/16" X 1 1/4" GRD 5 HEX BOLTS
2 - 7/16" NUT	2 - 7/16" LOCK WASHERS

INSTALLATION INSTRUCTIONS:

1. Locate and inventory all parts to become familiar with all brackets.
2. Starting with the driver's side, locate the hole on the side of the frame, directly below the rear most cab mount. Note that there is a cab mount bushing that may hang down significantly. (Picture A).
3. Next locate the oval hole on the bottom of the frame directly below the 1st hole (Picture B).
4. Using the supplied 1/2" bolt fisher, attach one 1/2 x 2 Grade 5 bolt along with one 1/2 star washer, and one 1x2 plate washer, then fish it through the first hole and into the second (Pictures C and D).
5. Next, using the same 1/2 bolt fisher, attach another 1/2 x 2 Grade 5 bolt, with one 1/2 star washer, and one 1 x 2 plate washer. You will then push the bolt through the 1st hole and pull it back out the same hole- (Pictures E and F). Be sure to leave the bolt fisher attached, so the bolt can not fall into the frame.
6. Now place the tie down into position, run the bolt fisher wire through the tie down (Picture G) to help with alignment. Attach Gusset Reinforcement Plate with 7/16" x 1 1/4" Grd5 Hex Bolts (Picture H). Be sure to also align the bottom bolt with the bottom hole (Picture I and J). Follow both bolts with one 1/2 flat washer, one 1/2 lock washer and one 1/2 nut. Tighten to 60ft lbs.
7. Repeat for passenger side.

***NOTE: THE INCLUDED TIE DOWN INSERTS HAVE TWO PRE-DRILLED PIN LOCATIONS. WHEN HOOKING UP YOUR CAMPER, EITHER HOLE MAY BE USED PROVIDING THERE IS A MINIMUM OF 2" CLEARANCE BETWEEN THE CHAIN/TURNBUCKLE ATTACHING ASSEMBLY AND THE TRUCK BED WALL. THERE ARE ALSO TWO PRE-PUNCHED HOLES LOCATED ON THE TRIANGULAR BULLET PLATE ON THE END OF EACH INSERT. WHILE EITHER OF THE TWO HOLES CAN BE USED, THE HOLE THAT PROVIDES THE GREATEST ANGLE IS PREFERRED.**

DRIVERS FRONT

A



B



C



D



E



F



G

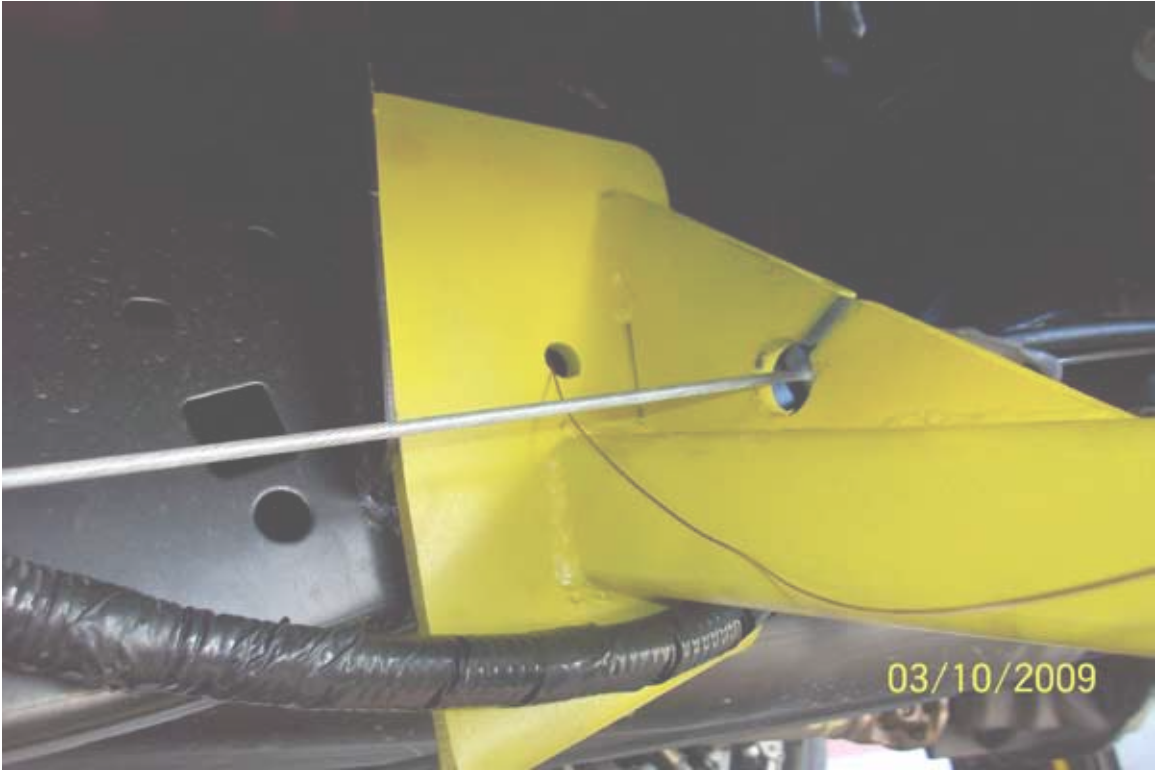

H



I

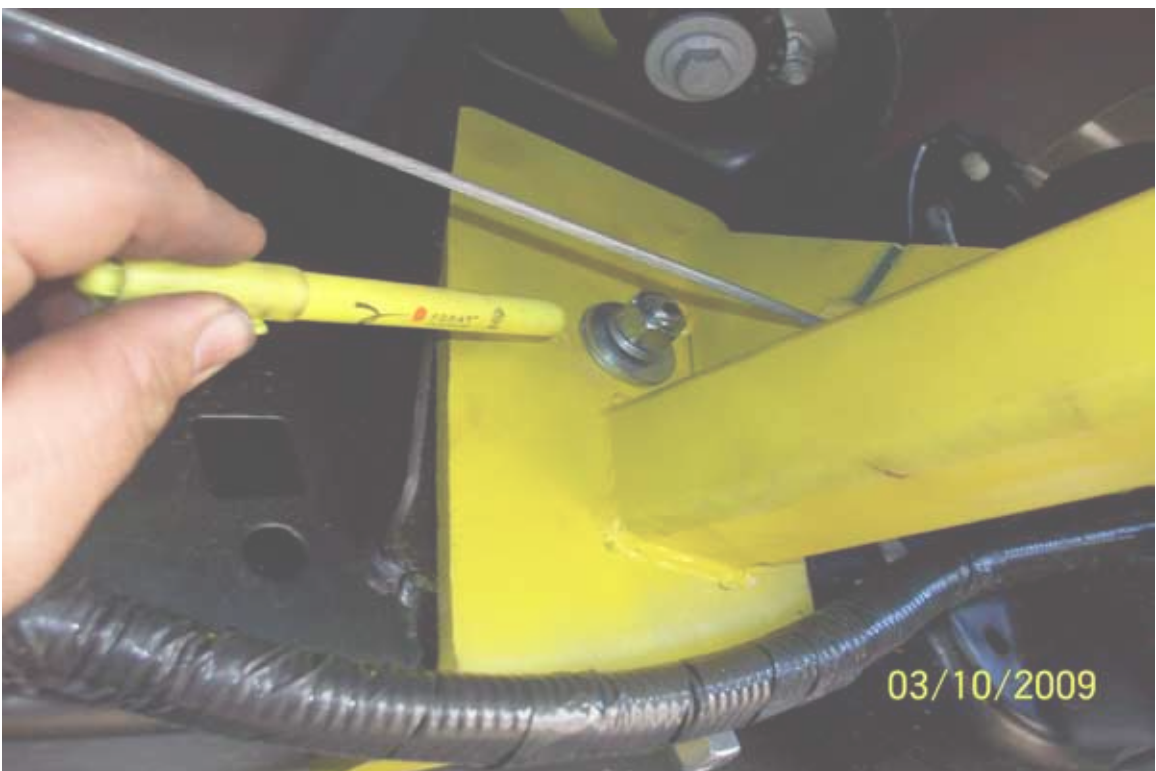

J



FIG 4



FIG 4B



FIG 4C



INSTRUCTIONS FOR MAINTENANCE OF POLISHED STAINLESS STEEL PRODUCTS



Torklift utilizes quality grade 304 stainless steel in this product.

304 stainless steel is well known for its anti corrosive properties, however in some environments such as coastal regions or when in contact with some road chemicals, corrosion may occur.

We recommend occasional polishing of our product to maintain its attractive finish. Use an approved stainless steel cleaning/polishing product which can be purchased from any automotive supplier.

- ▶ *Protect and Finish Off Your Tie Downs*
- ▶ *Minimizes the Effects of the Environment*
- ▶ *Kit includes: 2 cap covers, 2 expansion plugs*

Tie Down Cover

FINISHING KIT

TORKLIFT INTERNATIONAL
Celebrating Over 35 Years

1.800.246.8132
PART #: A7009

PART NUMBER: A7009

Frame Mounted Tie Downs



Leading the camper tie down industry in strength, quality, advanced design and installation. TorkLift TRUE frame mounted tie downs are far superior to all tie down systems available.

The TorkLift system is unique in its design and is patented. Four independent tie down points (with no belly or crossbar) working much like your receiver type trailer hitch as the inserts are removable allowing the system to be virtually undetectable when not in use.

They are designed for each make and model to fit tight to the frame so as not to compromise ground clearance. TorkLift tie downs are not universal 'one size fits all' therefore all the problems with correct fit for each particular application have been eliminated.

**VISIT WWW.TORKLIFT.COM
FOR MORE INFORMATION**

Super Hitch

High strength extended hitch system engineered for safely towing all types of trailers behind your truck and camper. With a towing capacity of 12,000 lbs. with an extension, (17,000 lbs. without) the SuperHitch is rated the strongest in the industry.



CONTACT YOUR LOCAL DEALER FOR MORE DETAILS

TORKLIFT'S BOLT FISHING GUIDE

Your guide to understanding the installation of our frame mounted tie downs.

Coiled End of Bolt Fisher

Note: The hardware may vary as to what is being fished along with the bolt. In this instance a 1" X 2" plate washer is being fished along with the hex bolt. Different applications may require fishing through various star washers and flat washers for example.

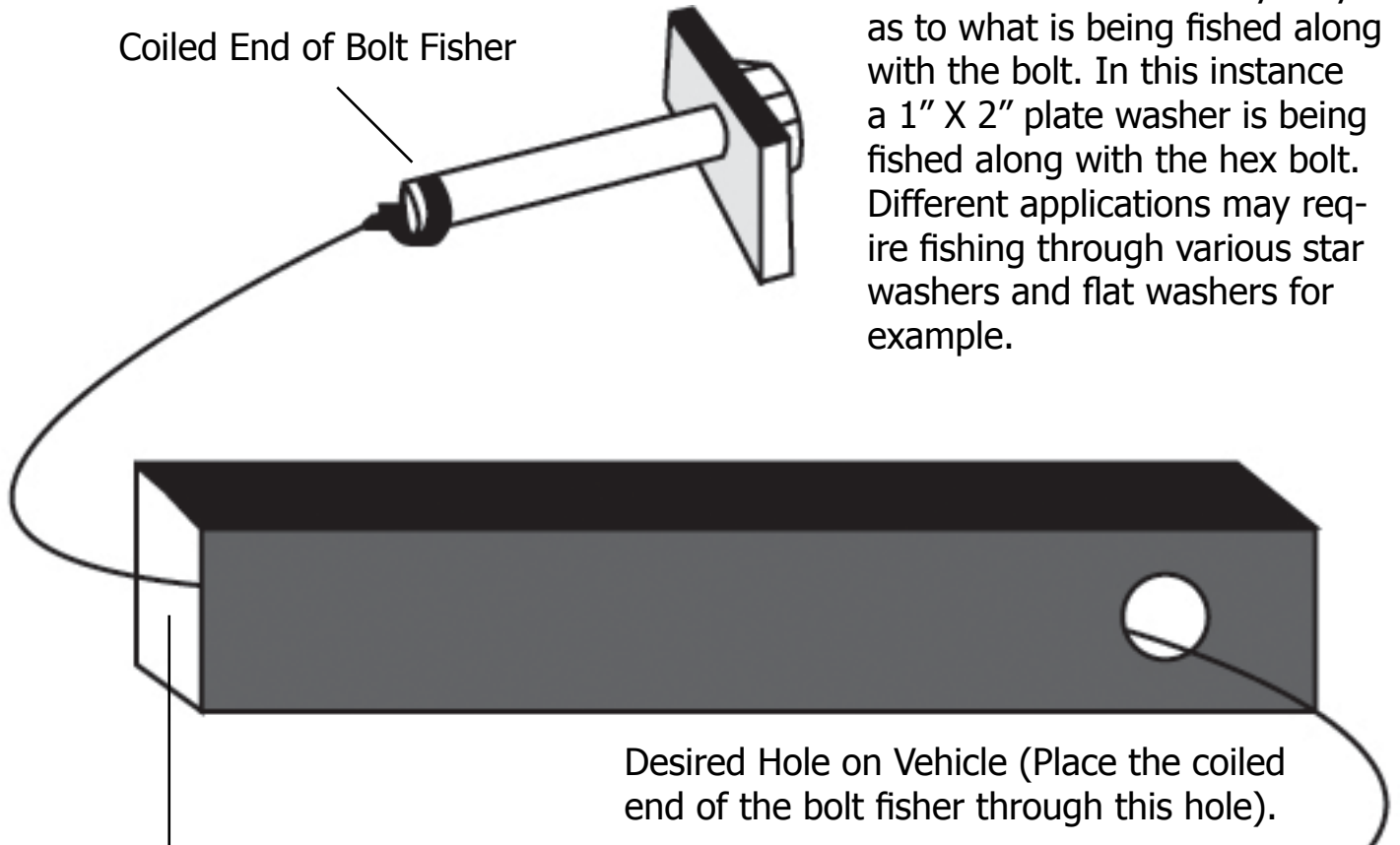

Desired Hole on Vehicle (Place the coiled end of the bolt fisher through this hole).

This side of the Bolt Fisher should come out of a hole where the required hardware (for example 1" X 2" plate washer) can pass through

Opposite End of Bolt Fisher

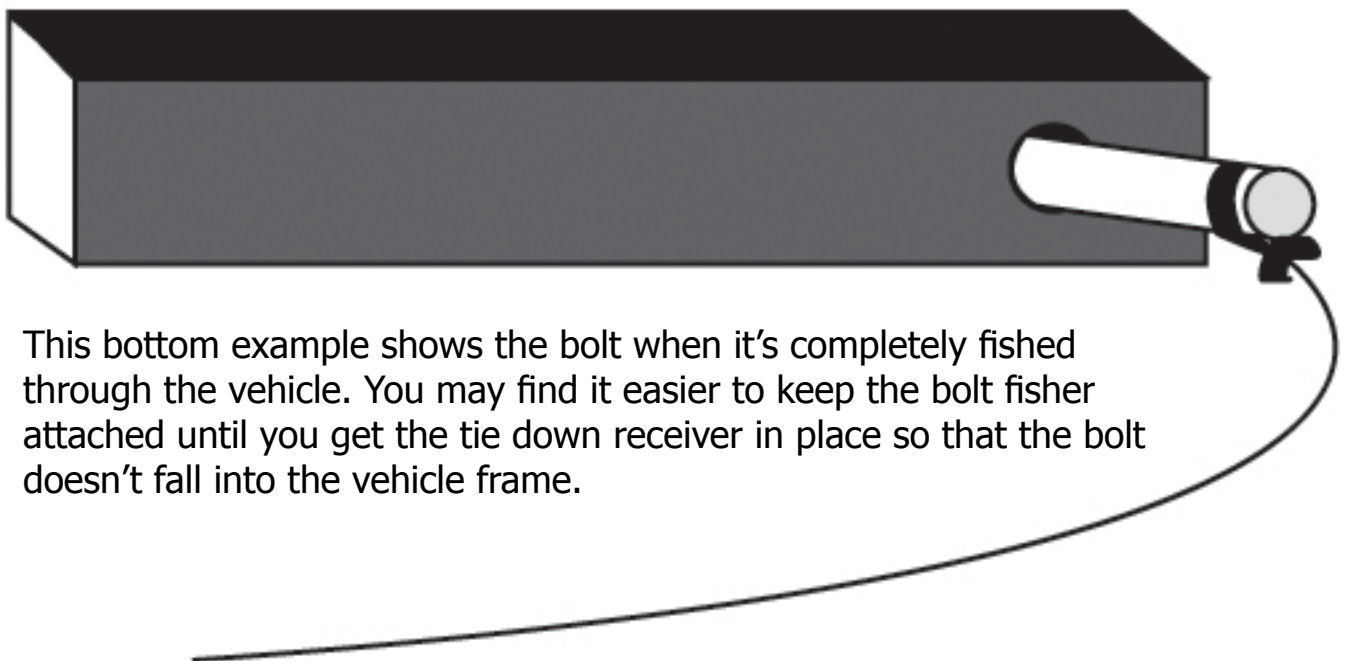

This bottom example shows the bolt when it's completely fished through the vehicle. You may find it easier to keep the bolt fisher attached until you get the tie down receiver in place so that the bolt doesn't fall into the vehicle frame.

WARNING: PULLING TOO HARD ON THE BOLT FISHER CAN RESULT IN LOST FASTENERS, OR BROKEN BOLT FISHER.

TIEDOWN INSERT INSTALLATION INSTRUCTIONS

On one end of each of your tiedown inserts is a triangular plate referred to by Torklift as a bullet plate. Your tiedown inserts should be installed with the shorter side of the bullet plate facing away from each other, i.e.. The shorter side of the front insert should point to the front of the truck and the shorter side of the rear insert should point towards the rear of the truck.

Once installed, attach the TorkLift directional stickers to the face of the bullet plate on the insert as a reminder.

DRIVERS SIDE FRONT



DRIVERS SIDE REAR



SHORTER SIDE

TURNBUCKLE SPRINGLOAD OPTIONS

CONTACT YOUR LOCAL DEALER FOR MORE DETAILS

Torklift requires all 4 tiedown points to be spring loaded in order to qualify for our manufacturer's

Industry Exclusive Camper Anchor and Truck Frame Warranty

BASIC SPRINGLOAD KIT - S9000

**Includes 2 External Springload Units
& 2 Heavy Duty Forged Turnbuckles.
Lifetime Guarantee**



FASTGUNS LEVER ACTION TURNBUCKLES

**S9520-GREY SS / S9521-WHITE SS / S9527-POLISHED SS
FOR BED MOUNTED TIEDOWNS**

**S9522-GREY SS/ S9523-WHITE SS/ S9526-POLISHED SS
S9529-BLACK SS**

FRAME OR BUMPER MOUNTED TIEDOWNS

**Includes 2 Stainless Steel Turnbuckles with an Internal
"Set" Spring. Available in 2 Lengths and 3 Finishes
(Grey, White or Polished Stainless Steel)
Lifetime Guarantee**



FASTGUN DERRINGERS

Zinc S9524

Stainless Powdercoat S9525

Polished Stainless S9528

**Transforms Your Pre-Existing Conventional
Turnbuckles into a Lever Action
FastGun Style Turnbuckle.
Kit includes 4 lever action Derringers**



SPRINGLOAD XL KIT - S9050

**This set includes 2 Long Chrome Barreled
Turnbuckles with an Internal "Set" Spring.
The Springload XL Kit comes with a Pol-
ished Chrome Finish and is compatible
with the FastGun Derringers.
2 year warranty**

RECOMMENDED TRUCK CAMPER

INSTALLATION INSTRUCTIONS

When securing any heavy load (especially a camper) in your truck bed, your front tie down points should pull the load forward as much as possible. Some camper anchor points may differ with different manufacturers, as well as the camper jack mounting locations. Your Torklift tie down inserts have offset triangular brackets to increase the angle of pull. These are designed to be used in the front facing forward, and the rear facing rearward but can be used in either front or rear. These recommendations are to be considered and followed as a basic rule of thumb . Obviously there will be some applications where this may not be possible. At a minimum, if opposite pull of both front and rear tiedowns cannot be achieved for whatever reason, you should have at least a forward pull at the front or rear location.

If your camper does not come with Rubber Bumpers on the front lower portion of the camper, installing Rubber Bumpers (Torklift has Rubber Bumpers available Part A7001) or using a block of wood such as a 2 x 4 in the bed, will prevent the camper from damaging the front bulk head of the truck bed.

Minor movement (or settling) can occur in some incidental harsh driving conditions (on or off road). A rubber bed mat is not a requirement to maintain the lifetime warranty on a Torklift system, but a strong recommendation simply as a safety precaution to protect the truck bed, the bottom of the camper and to give the camper additional support.

TORKLIFT DOES NOT RECOMMEND: Installing your truck camper in your truck on top of a drop in plastic bed liner!!! The drop in plastic bed liners can slide on top of the truck bed surface, and the camper can slide on top of the slick surface of the bed liner. The liner can also act as a spring causing a trampoline effect increasing vertical truck camper movement, independent of the vehicle, possibly resulting in truck bed, and camper damage!

INSTRUCTIONS FOR FINISH MAINTENANCE **OF TORKLIFT PRODUCTS**

POWDER COATED STEEL:

To keep your Torklift products looking good follow these guidelines. All steel powder coated Torklift products are sandblasted for maximum adhesion and use a high quality industrial urethane based powder coat. Due to the extreme, harsh, undercar environment that your Torklift products live in, (consistently sprayed with corrosive road chemicals such as salt, and road debris), Torklift does not warranty the powder coated finish.

To minimize corrosion from these factors on powder coated steel products, Torklift recommends regularly cleaning and inspecting the powder coated surface and touching up any affected areas with an enamel or urethane based aerosol paint product. If there are any areas of surface rust, there are also aerosol spray rust converters available on the market that can be used as a preparation to touch-up paint application. These finish maintenance products are available at any automotive parts supplier.

POLISHED STAINLESS STEEL :

Torklift utilizes quality grade 304 stainless steel in our stainless steel polished products. 304 stainless steel is well known for its anti-corrosive properties. However, in some environments such as coastal regions or when coming in contact with some road chemicals, corrosion may occur.

For a quick clean simply use WD40 and a cloth rag. We also recommend occasional polishing of our polished stainless products to maintain their attractive finish. Use an approved stainless steel chrome or aluminum mag wheel polish cleaning product which can be purchased from any automotive parts supplier.

Torklift International Limited Lifetime Warranty Information

322 N Railroad Ave, Kent WA 98032

Torklift will require proof of purchase to register, with pictures of any defective product before issuing a replacement. Torklift will not register any product without proof of purchase, which can be faxed, scanned, emailed, or mailed to the information provided below. Torklift warrants its hitches, custom hitch receivers, frame mounted tiedowns, turnbuckles, and accessories (excluding wireharnesses which carry a 90 day warranty) from date of purchase against defects in material and workmanship under normal use and service for the ownership life of the original consumer purchaser. Torklift will replace **FREE OF CHARGE** any part which proves defective in material or workmanship when presented to Torklift, **TRANSPORTATION CHARGES PREPAID** by purchaser, at the address above. **THIS WARRANTY IS LIMITED TO DEFECTIVE PARTS REPLACEMENT ONLY. LABOR CHARGES AND/OR DAMAGE INCURRED IN INSTALLATION OR REPLACEMENT, AS WELL AS INCIDENTAL AND CONSEQUENTIAL DAMAGES CONNECTED THEREWITH ARE EXCLUDED.** This warranty does not include the finish or paint on our products. Rusting, cracking or peeling of the finish is also excluded. Some states do not allow the exclusion or limitation of incidental or consequential damages, so the above limitation or exclusion may not apply to you. Any damage to Torklift products as a result of misuse, abuse, neglect, accident, improper installation or any use violative of instructions furnished by Torklift **WILL VOID THE WARRANTY.** This warranty gives you specific legal rights, and you may also have rights which vary from state to state. With warranty service, you may be able to go to a small claims court, a state court or a federal district court.



322 N. RAILROAD PHONE (800) 246-8132
KENT, WA 98032 FAX (253) 854-8003

OR VISIT OUR WEBSITE: WWW.TORKLIFT.COM

Dear Valued Customer,

Thank you for making TorkLift your choice for truck, camper packages and accessories for your vehicle. By choosing TorkLift products, you have chosen a company that has been serving the RV industry for nearly 40 years and whose name has become synonymous with strength, quality and advanced design and installation.

Please take a few moments of your time to complete the Product Registration Warranty Card on the next page. When registering your newly purchased TorkLift products, you can be assured that your contact information is secure and that you and your product are getting the attention and respect that you deserve.

Thank you again for choosing TorkLift quality products.

Register for your lifetime warranty and receive a free Torklift International gift.

To Fax: Send copies of the questionnaire, warranty card and receipt to 253-854-8003

To E-mail: Send copies of the questionnaire, warranty card and receipt to warranty@torklift.com

To Mail: Send to Torklift International 322 Railroad Ave., Kent, WA 98032



OFFICIAL WARRANTY REGISTRATION CARD

PLEASE FILL OUT THIS FORM COMPLETELY AND RETURN TO TORKLIFT WITHIN 30 DAYS OF PURCHASE ACCOMPANIED BY A COPY OF YOUR ORIGINAL RECEIPT

TODAY'S DATE: _____

1. PART(S) PURCHASED

PART #: _____ PART #: _____

PART #: _____ PART #: _____

2. PURCHASER INFORMATION

NAME: _____

ADDRESS: _____

CITY: _____ STATE: _____ ZIP / POSTAL CODE: _____

PHONE: (____) _____ - _____ EMAIL: _____

3. TRUCK INFORMATION

YEAR: _____ MAKE: _____

MODEL: _____ BED LENGTH: _____

4. CAMPER INFORMATION

YEAR: _____ MAKE: _____ MODEL: _____

5. DEALER INFORMATION

PURCHASED FROM: _____

ADDRESS: _____

CITY: _____ STATE: _____ ZIP / POSTAL: _____

INSTALLED BY: OWNER ABOVE DEALER ANOTHER DEALER

IF ANOTHER DEALER, WHO: _____