



Portable Omni-directional HDTV Antenna Model OA1501

Contents

- KING OmniGo Antenna
- Tripod Mount
- Magnetic Vehicle Mount with Protective Rubber Base Cover
- Coax Cable
- Power Injector
- 110 VAC Power Supply
- 12 VDC Auxiliary Power Cord
- Carry Bag

See reverse side for setup and operation.

FAQs

Which way should I point my KING OmniGo?

The KING OmniGo is an omni-directional antenna and receives signal from any direction. No pointing is required.

Why am I not getting any channels?

Make sure all of the proper connections are made as shown on the reverse side. In some areas, there may not be over-the-air channels available.

Can I connect the power injector in either direction?

No. Make sure to connect the power injector only in the direction shown on the reverse side.

Can I use my KING OmniGo in wet weather?

Yes! The KING OmniGo is highly weather-resistant.

Can I register my KING OmniGo?

Yes. Please go to kingconnect.com/products/product-registration.

Limited Warranty

Every new KING OmniGo Antenna is covered by a one-year parts and labor limited warranty from the date of original purchase: The customer is not responsible for the cost of replacement parts or labor if the original part is determined to be defective under the terms of the warranty. The customer is responsible for these costs after one year.

Should any trouble develop during the warranty period, contact KING. You must contact KING before the warranty period expires. The customer must supply proof of purchase (such as a dated sales receipt) when requesting warranty service. If customer cannot supply proof of purchase, warranty period shall start 30 days after date of manufacture. Only KING will perform warranty evaluations and repairs.

If it is determined that the unit needs to be returned to KING, customer must return COMPLETE product, freight prepaid, to:

KING, 11200 Hampshire Avenue South, Bloomington, MN 55438-2453.

If inspection shows the trouble is caused by defective workmanship or material, KING will repair (or at its option, replace) without charge. When returning product, KING will supply an RMA number (Return Merchandise Authorization). This number must be clearly written on the box. Failure to clearly write RMA number on box may result in delays in processing claim. Along with product, customer should include in the box: his/her name, address, daytime phone number, proof of purchase and description of the problem.

This warranty does not cover installation and external wiring, or remanufactured units. This warranty is not transferable from the original owner. This warranty also does not apply where:

- The product has been abused, misused, improperly installed or improperly maintained.
- Repairs have been made or attempted by others that are not certified by KING to do such repairs.
- Repairs are required because of normal wear and tear.
- Alterations have been made to the product.
- The product enclosure has been opened.
- Damage has been caused by power washing.
- Circumstances beyond the control of KING cause the product to no longer operate correctly.
- Customer is not the original owner.

In no event shall KING be liable for any indirect, incidental, or consequential damages from the sale or use of the product. This disclaimer applies both during and after the term of the warranty. KING disclaims liability for any implied warranties, including implied warranties of "merchantability" and "fitness for a specific purpose," after the one year term of this warranty.

This warranty gives you specific legal rights, and you may also have other rights, which vary from state to state. Some states do not allow the exclusion or limitation of incidental or consequential damages, so the above limitation or exclusion may not apply to you. Some states do not allow limitations on how long an implied warranty lasts, so the above limitation may not apply to you.

Operation

1 Set up and make connections as shown below.

3 Watch TV. Enjoy!

2 Perform a channel scan with your digital tuner or digital TV.

Connections

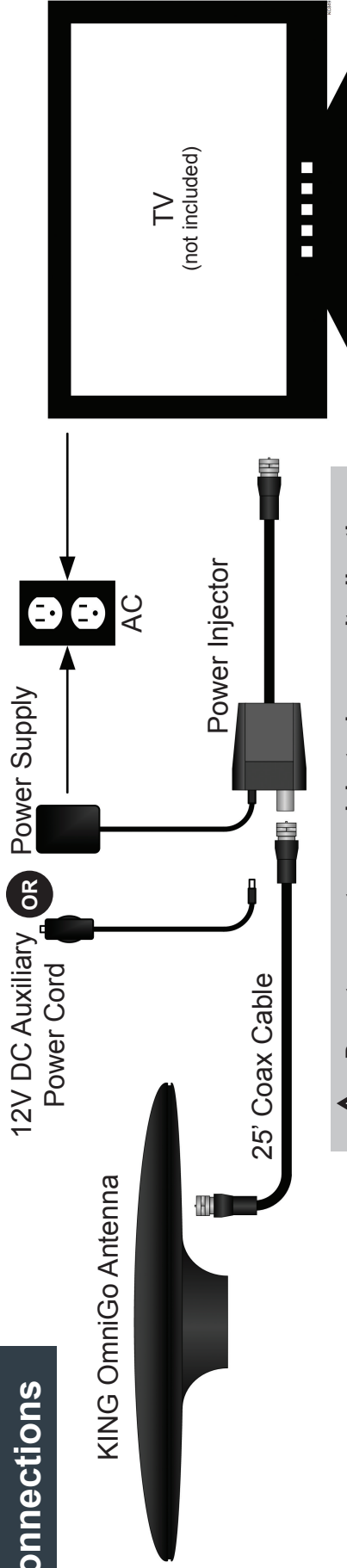

! Do not connect power injector in opposite direction. Incorrect connections may damage equipment.

Antenna Setup

Magnetic base may be temporarily mounted to any magnetic surface. Use rubber base cover to protect surface.

Not for in-motion use!

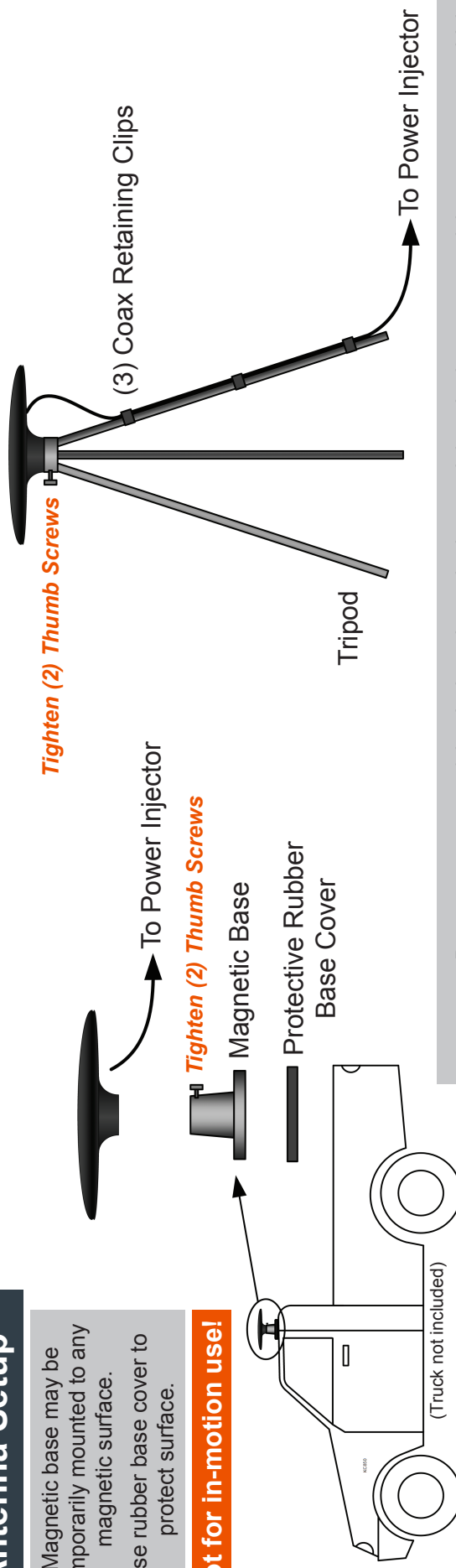

- Do not put antenna/tripod where it can be bumped, knocked over or struck by a person or vehicle.
- Do not put near any heat sources.
- Do not route coax where it can be tripped on or run over by a vehicle.
- Do not overtighten coax connections.
- Do not put sharp bends or kinks in coax cable.



KING

11200 Hampshire Ave S, Bloomington MN 55438
PH 952.922.6889 FAX 952.922.8424
www.kingconnect.com 22544 Rev A ©2016
KING OmniGo is a trademark of Electronic Controlled Systems, Inc.
KING is a registered trademark of Electronic Controlled Systems, Inc.