



SQUARE HYDRAULIC JACK

INSTALLATION & OWNER'S MANUAL



VISIT OUR WEBSITE @
WWW.BIGFOOTLEVELER.COM

Quadra Mfg. Inc.

CORPORATE
305 US 131 SOUTH
WHITE PIGEON, MI 49099
1 (269) 483-9634

SOUTHERN DIVISION
305 US 131 SOUTH
WHITE PIGEON, MI 49099
1-800-699-6680

THERE ARE *SIX* KITS AVAILABLE:

12k Standard Single Point

- One Jack, One Pump, and Weatherproof Control Box.

12k Wireless Single Point

- One Jack, One Pump, and Wireless Key Fob & Emergency Switch Inside Tank.

12k Standard Slave Kit

- Two Jacks, One Pump, and Weatherproof Control Box,
- NO side to side leveling.

12k Wireless Slave Kit

- Two Jacks, One Pump, and Wireless Key Fob & Emergency Switch Inside Tank,
- NO side to side leveling.

12k Standard 2^{PT} Kit

- Two Jacks, Two Pumps, and Weatherproof Control Box,
- Jacks can run individually so side to side leveling can be achieved.

6k SQ20 1pt Kit

- One Jack, One Pump, and Toggle Switch Mounted to backside of Tank Assembly.

Standard Single Point

DESCRIPTION OF PART	PART #	QTY.
SQ1-24	M4020	1
Medium Tank Assembly Plastic Reservoir	M26850	1
TANK COVER	M12002	1
#10 TEK SCREW (FOR TANK COVER)	M80940	2
TABS (FOR MOUNTING TANK TO LEG)	M28725	2
3/8-24 HEX BOLT (MOUNTS TAB TO LEG)	M80212	2
90° FITTINGS	M57001	2
80 AMP BREAKER	M46300	1
#10-16X1.25" SELF-TAPPING SCREWS HEX FLANGE HEAD	M80938	2
GRAY BOX 1PT	M37022	1
PUSH ON CONNECTORS	M96000	2
5/16 RING TERMINAL	M94000	1
3' Battery Cable	M48000	2
3/8 Battery Lugs	M99000	4
HOSE w/ FITTINGS – 17, 19	M52000	2
"B" Brackets - 4"	M28930	4
7/16-14 G8 HEX BOLT 1.75 LONG	M80316	4
7/16-14 G8 HEX NUT	M80346	4
7/16 G8 LOCKWASHER	M80344	4
½-13 G8 HEX BOLT 5.5" LONG	M80425	2
½-13 G8 HEX BOLT 6.5" LONG	M80426	2
½-13 G8 HEX NUT (BLACK)	M80462	4
½ LOCKWASHER	M80452	4

Wireless Single Point

DESCRIPTION OF PART	PART #	QTY.
SQ1-24	M4020	1
Medium Tank Assembly Plastic Reservoir	M26850	1
TANK COVER	M12002	1
#10 TEK SCREW (FOR TANK COVER)	M80940	2
TABS (FOR MOUNTING TANK TO LEG)	M28725	2
3/8-24 HEX BOLT (MOUNTS TAB TO LEG)	M80212	2
90° FITTINGS	M57001	2
80 AMP BREAKER	M46300	1
#10-16X1.25" SELF-TAPPING SCREWS HEX FLANGE HEAD	M80938	2
WIRELESS 1pt KIT (RECEIVER & KEY FOB) (2 ND GEN)	M37028	1
#8 PHILLIPS HEAD MACHINE SCREWS (FOR TANK)	M80916	6
#8 HEX NUT w/ SPROCKET FLANGE	M80918	6
PUSH ON CONNECTORS (2 FOR TANK)	M96000	4
5/16 RING TERMINAL (3 FOR TANK)	M94000	4
FEMALE SPADE CONNECTOR (ALL FOR TANK)	M91500	6
3' Battery Cable	M48000	2
3/8 Battery Lugs	M99000	4
HOSE w/ FITTINGS – 17, 19	M52000	2
"B" Brackets - 4"	M28930	4
7/16-14 G8 HEX BOLT 1.75 LONG	M80316	4
7/16-14 G8 HEX NUT	M80346	4
7/16 G8 LOCKWASHER	M80344	4
½-13 G8 HEX BOLT 5.5" LONG	M80425	2
½-13 G8 HEX BOLT 6.5" LONG	M80426	2
½-13 G8 HEX NUT (BLACK)	M80462	4
½ LOCKWASHER	M80452	4

Standard Slave Kit

DESCRIPTION OF PART	PART #	QTY.
SQ1-24	M4020	2
Medium Tank Assembly Plastic Reservoir	M26850	1
TANK COVER	M12002	1
#10 TEK SCREW (FOR TANK COVER)	M80940	2
"TEE" FITTING SWIVEL	M57018	2
90° JIC SWIVEL	M57007	4
TABS (FOR MOUNTING TANK TO LEG)	M28725	2
3/8-24 HEX BOLT (MOUNTS TAB TO LEG)	M80212	2
90° FITTINGS	M57001	4
80 AMP BREAKER	M46300	1
#10-16 x 1.25" SELF-TAPPING SCREWS HEX FLANGE HEAD	M80938	2
GRAY BOX 1PT	M37022	1
PUSH ON CONNECTORS	M96000	2
RING TERMINAL	M94000	1
3' Battery Cable	M48000	2
3/8 Battery Lugs	M99000	4
HOSE w/ FITTINGS – 17, 19, 12'6" (2x)	M52000	4
"B" Brackets - 4"	M28930	8
7/16-14 G8 HEX BOLT 1.75 LONG	M80316	8
7/16-14 G8 HEX NUT	M80346	8
7/16 G8 LOCKWASHER	M80344	8
½-13 G8 HEX BOLT 5.5" LONG	M80425	4
½-13 G8 HEX BOLT 6.5" LONG	M80426	4
½-13 G8 HEX NUT (BLACK)	M80462	8
½ LOCKWASHER	M80452	8



Wireless Slave Kit

DESCRIPTION OF PART	PART #	QTY.
SQ1-24	M4020	2
Medium Tank Assembly Plastic Reservoir	M26850	1
TANK COVER	M12002	1
#10 TEK SCREW (FOR TANK COVER)	M80940	2
"TEE" FITTING SWIVEL	M57018	2
90° JIC SWIVEL	M57007	4
TABS (FOR MOUNTING TANK TO LEG)	M28725	2
3/8-24 HEX BOLT (MOUNTS TAB TO LEG)	M80212	2
90° FITTINGS	M57001	4
80 AMP BREAKER	M46300	1
#10-16 x 1.25" SELF-TAPPING SCREWS HEX FLANGE HEAD	M80938	2
WIRELESS 1pt KIT (RECEIVER & KEY FOB) (2 ND GEN)	M37028	1
#8 PHILLIPS HEAD MACHINE SCREWS (FOR TANK)	M80916	6
#8 HEX NUT w/ SPROCKET FLANGE	M80918	6
PUSH ON CONNECTORS (2 FOR TANK)	M96000	4
5/16 RING TERMINAL (2 FOR TANK)	M94000	4
FEMALE SPADE CONNECTOR (ALL FOR TANK)	M91500	6
3' Battery Cable	M48000	2
3/8 Battery Lugs	M99000	4
HOSE w/ FITTINGS – 17, 19, 12'6" (2x)	M52000	4
"B" Brackets - 4"	M28930	8
7/16-14 G8 HEX BOLT 1.75 LONG	M80316	8
7/16-14 G8 HEX NUT	M80346	8
7/16 G8 LOCKWASHER	M80344	8
½-13 G8 HEX BOLT 5.5" LONG	M80425	4
½-13 G8 HEX BOLT 6.5" LONG	M80426	4
½-13 G8 HEX NUT (BLACK)	M80462	8
½ LOCKWASHER	M80452	8

Standard 2^{PT} Kit

DESCRIPTION OF PART	PART #	QTY.
SQ1-24	M4020	2
Medium Tank Assembly Plastic Reservoir	M26850	2
TANK COVER	M12002	2
#10 TEK SCREW (FOR TANK COVER)	M80940	4
TABS (FOR MOUNTING TANK TO LEG)	M28725	4
3/8-24 HEX BOLT (MOUNTS TAB TO LEG)	M80212	4
90° FITTINGS	M57001	4
80 AMP BREAKER	M46300	1
#10 SELF THREADING SCREWS HEX FLANGE HEAD	M80938	2
GRAY BOX 2PT	M37007	1
PUSH ON CONNECTORS	M96000	4
5/16 RING TERMINAL	M94000	2
3' Battery Cable	M48000	3
3/8 Battery Lugs	M99000	6
HOSE w/ FITTINGS – 17, 19 (2 EACH)	M52000	4
"B" Brackets - 4"	M28930	8
7/16-14 G8 HEX BOLT 1.75 LONG	M80316	8
7/16-14 G8 HEX NUT	M80346	8
7/16 G8 LOCKWASHER	M80344	8
½-13 G8 HEX BOLT 5.5" LONG	M80425	4
½-13 G8 HEX BOLT 6.5" LONG	M80426	4
½-13 G8 HEX NUT (BLACK)	M80462	8
½ LOCKWASHER	M80452	8

SQ20 6k-lb Jack

(3 1/2" Outer Square Tubing) Installation Diagram

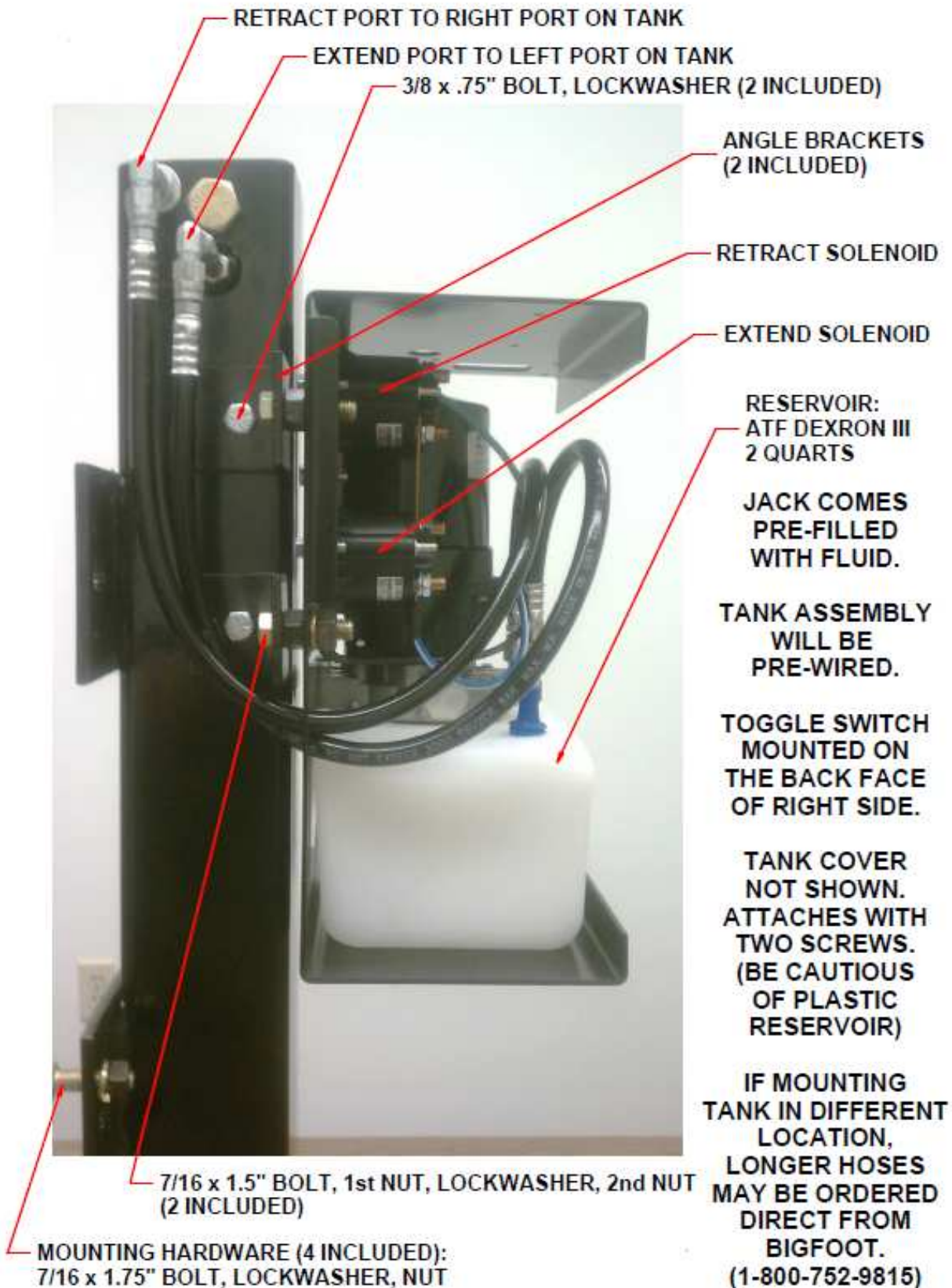

MOUNTING INSTRUCTIONS

BOLT ON:

- Mount the Angle brackets onto the rear of the Bigfoot jack using optional 7/16 hardware.
- Level trailer and support front of the trailer with jack stands.
- Unbolt and remove existing jack (and brackets).
- Set the Bigfoot jack temporarily to desired placement.
- (Recommended Ground Clearance: Minimum of 8 inches)
- Mark placement of mounting holes on frame.
- If existing holes in channel do not match the bracket holes, drill holes in channel using 15/32 drill bit.
- Attach your Bigfoot Jack to frame channel with the 7/16 hardware.

OR

- Using the “B” brackets (4” long brackets with slots in them, shipped loose) These brackets bolt to the jack plate bracket using the 7/16 hardware. And bolt to the bulkhead frame of your horse trailer using the 5 ½” & 6 ½” long bolts (½” hardware).

WELD ON:

- Level the trailer and support front of trailer with jack stands.
- If welding to existing jacks, retract jack fully: otherwise remove the jack.
- Mount supplied Angle brackets to the brackets on the back of your Bigfoot Jack using the optional 7/16 hardware, adjusting the width of the Angle Bracket to allow the Bigfoot Jack to fit the width of the existing jack or frame channel.
- Set the Bigfoot Jack to the desired placement.
- (Recommended Ground Clearance: Minimum of 8 inches)
- Run a continuous weld on all edges of each side of the Angle Bracket that is in contact with existing jack or channel.

HOSE PLUMBING:

- If the tank hoses are not already connected to the leg, the upper left fitting on the tank assembly goes to the bottom fitting on the Bigfoot Jack, (the longest hose.)

MEDIUM TANK ASSEMBLY DIAGRAM

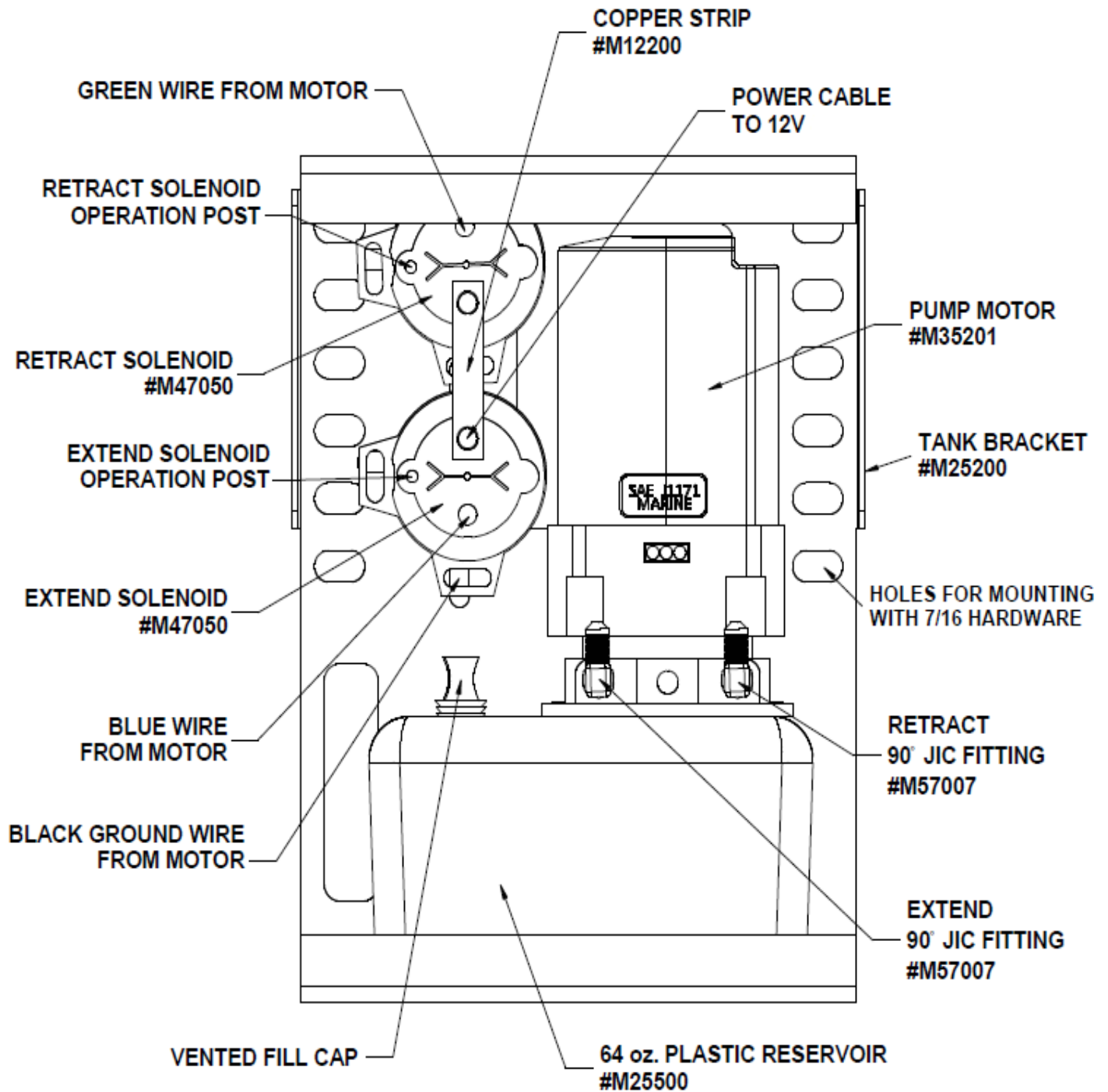

NOT PICTURED:

TANK COVER (BLACK TEXTURED PLASTIC) #M12002

OVERALL DIMENSIONS:

9" WIDE
12.5" TALL
5.75" DEEP

ELECTRICAL AND FINAL PREP

- ▶ Hydraulic jack requires 12 volt battery; make sure you use at least a 4 gauge battery cable for the power to the jack.
- ▶ Remove plastic cover from pump assembly (if installed).
- ▶ (Standard kits) Mount weather proof control box assembly in a convenient location making sure to allow enough wire harness to reach the pump assembly.
- ▶ Most trailers have the battery mounted on the front of the trailer in a box; install the 80 amp breaker (if equipped) using the self tapping screws in-line somewhere between the jack and the battery.
- ▶ Hooking up the breaker: Using the battery cable (if equipped); attach one end of the cable to the bottom solenoid on the lug with the copper strip. Route the cable through the grommet holes in the marked AUX then attach the other cable (if equipped) to the circuit breaker post marked BAT and route the cable to the battery (DO NOT CONNECT UNTIL THE REST OF THE TANK WIRING IS COMPLETE)
- ▶ (Standard kits) Route the harness from the switch box through the grommet on the back of the pump. Connect the green wire with the white strip to the small post on the top solenoid (make sure to use the crimp on push on connector if supplied). Next, connect the solid green wire to the small post on the bottom solenoid. You may now connect the battery cable to the battery.
- ▶ In the event the Tank Assembly *is not* attached or mounted to steel; it is necessary to attach the AUX Ground from tank assembly to frame. (If tank Assembly *is* mounted to steel, the ground is reached thru the tank body and frame of vehicle.)
- ▶ At this point add fluid (ATF) to the pump (red fill cap) make sure you fill the tank so that the fluid is $\frac{3}{4}$ " below the top.
- ▶ Then you must press the extend button and fully extend the jack(s) until it reaches full extension. Let it set this way for 30 minutes, this bleeds the air from the lines.
- ▶ Once that is done lower your system and enjoy your brand new **BIGFOOT LEVELER**.

2nd Gen Wireless 1pt

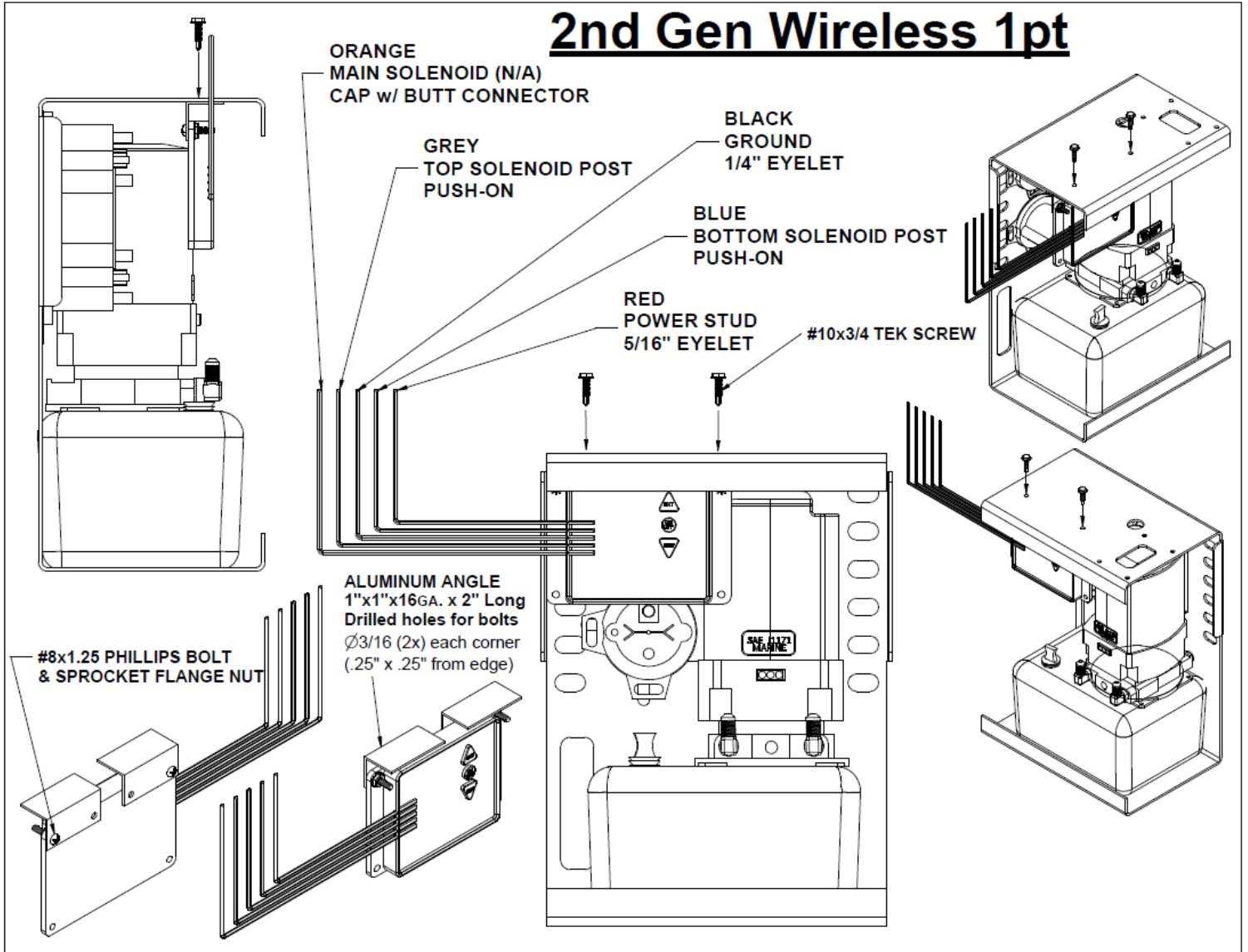

A weatherproof key fob is included in this kit as well. To sync the key fob to the receiver box, hold down the on/off button on the receiver until the light blinks, then press the on/off button on the fob. Your fob is now synced!

For operation, simply press the on/off button on the fob and then press & hold the extend button to lift the trailer and the retract button to lower the trailer. If you lose your key fob, or the battery runs out, follow the instructions on the next page.

1pt or Slave Wireless Emergency Controls

Operating your Jack with the Emergency Controls:

- 1.) Remove cover screws (two)
- 2.) Remove the cover
- 3.) Press ON/OFF switch
- 4.) Press EXTEND or RETRACT

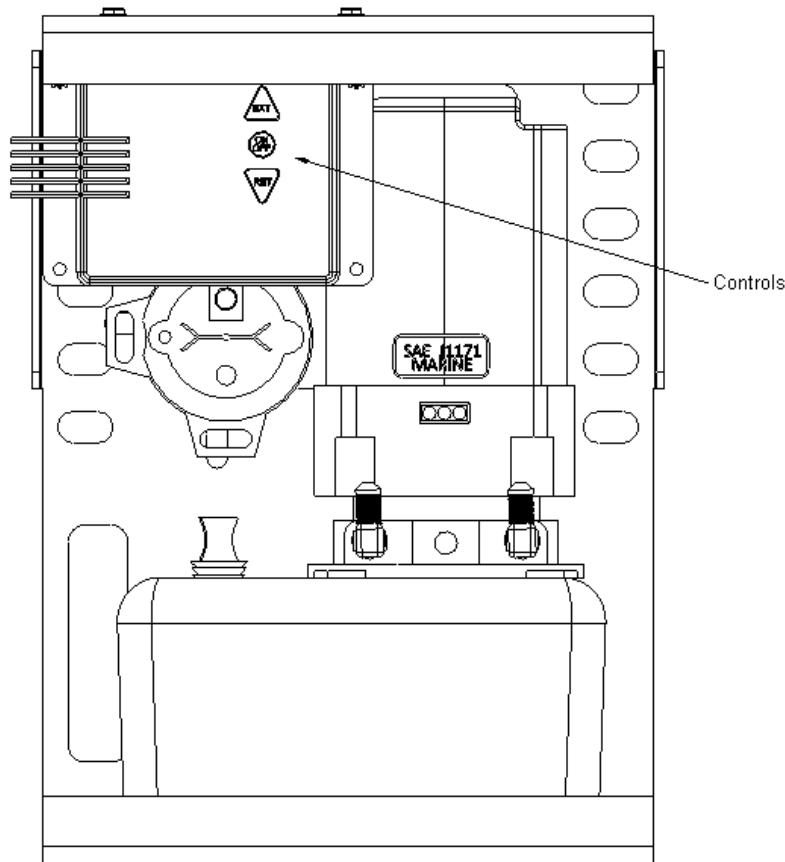

Primary Control for the Jack is your Key Fob, but if that is misplaced, there is still a way out!

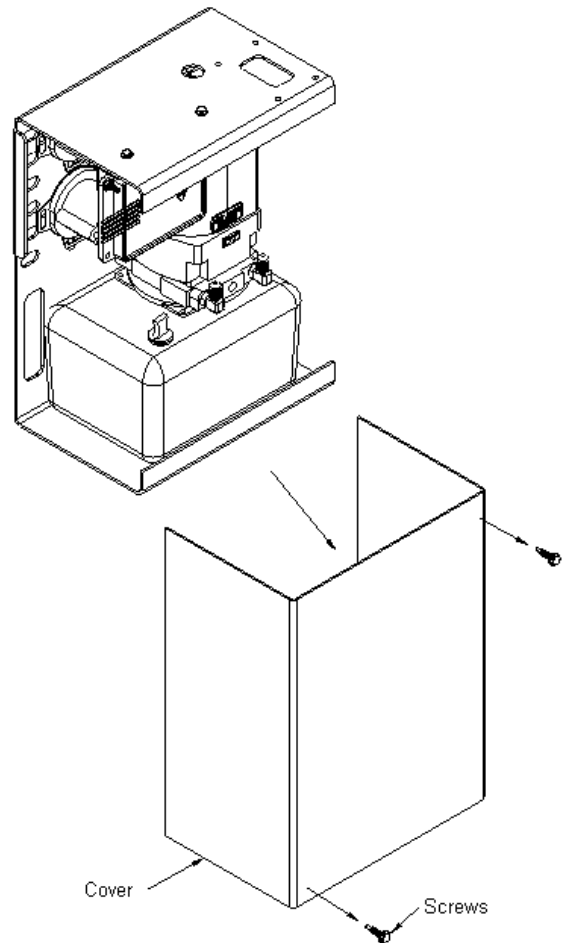

MEDIUM TANK ASSEMBLY

#M26850

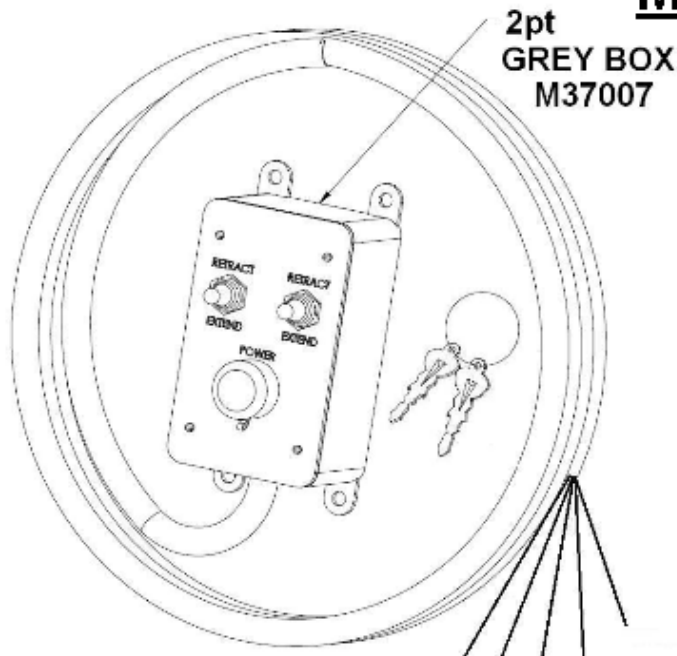

OVERALL DIMENSIONS:
9" WIDE
12.5" TALL
5.75" DEEP

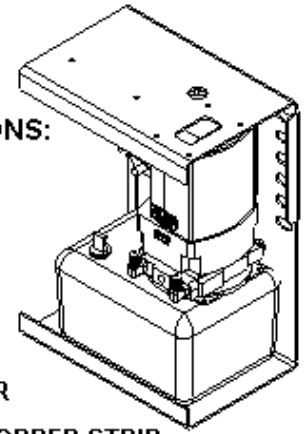

GREEN WIRE
FROM MOTOR

COPPER STRIP
#M12200

PUMP MOTOR
#M35201

**GREEN w/ WHITE
OR BLUE w/ WHITE
WIRE FROM BOX**
RETRACT SOLENOID
OPERATION POST

**RED WIRE
FROM BOX**

4 GA. BATTERY CABLE
ONE END HERE THEN
TO BREAKER MARKED 'AUX'
THEN FROM POST MARKED 'BAT'
TO POSITIVE TERMINAL
ON BATTERY

**GREEN WIRE
OR BLUE WIRE
FROM BOX**
EXTEND SOLENOID
OPERATION POST

BLUE WIRE
FROM MOTOR

BLACK GROUND WIRE
FROM MOTOR

VENTED FILL CAP

1pt GREY BOX (#M37022)
WIRES UP THE SAME WAY
(ONLY ONE SWITCH & ONE SET OF WIRES)

64 oz. PLASTIC
RESERVOIR
#M25500

EXTEND
90° JIC FITTING
#M57007

RETRACT
90° JIC FITTING
#M57007

NOT PICTURED:

TANK COVER (BLACK TEXTURED PLASTIC) #M12002

5/9/11

QUADRA
MANUFACTURING

MANUAL RETRACT & TOGGLE SWITCH WIRE DIAGRAM

MANUAL RETRACT (if equipped)

- ▶ If your jack is equipped with manual retract there will be a 6" hex bit in with your kit, there will also be a hole in the top of your tank assembly to access the drive at the top of the pump.
- ▶ Use a drill to retract or extend cylinder, this is not a quick operation but will work in case of emergency.

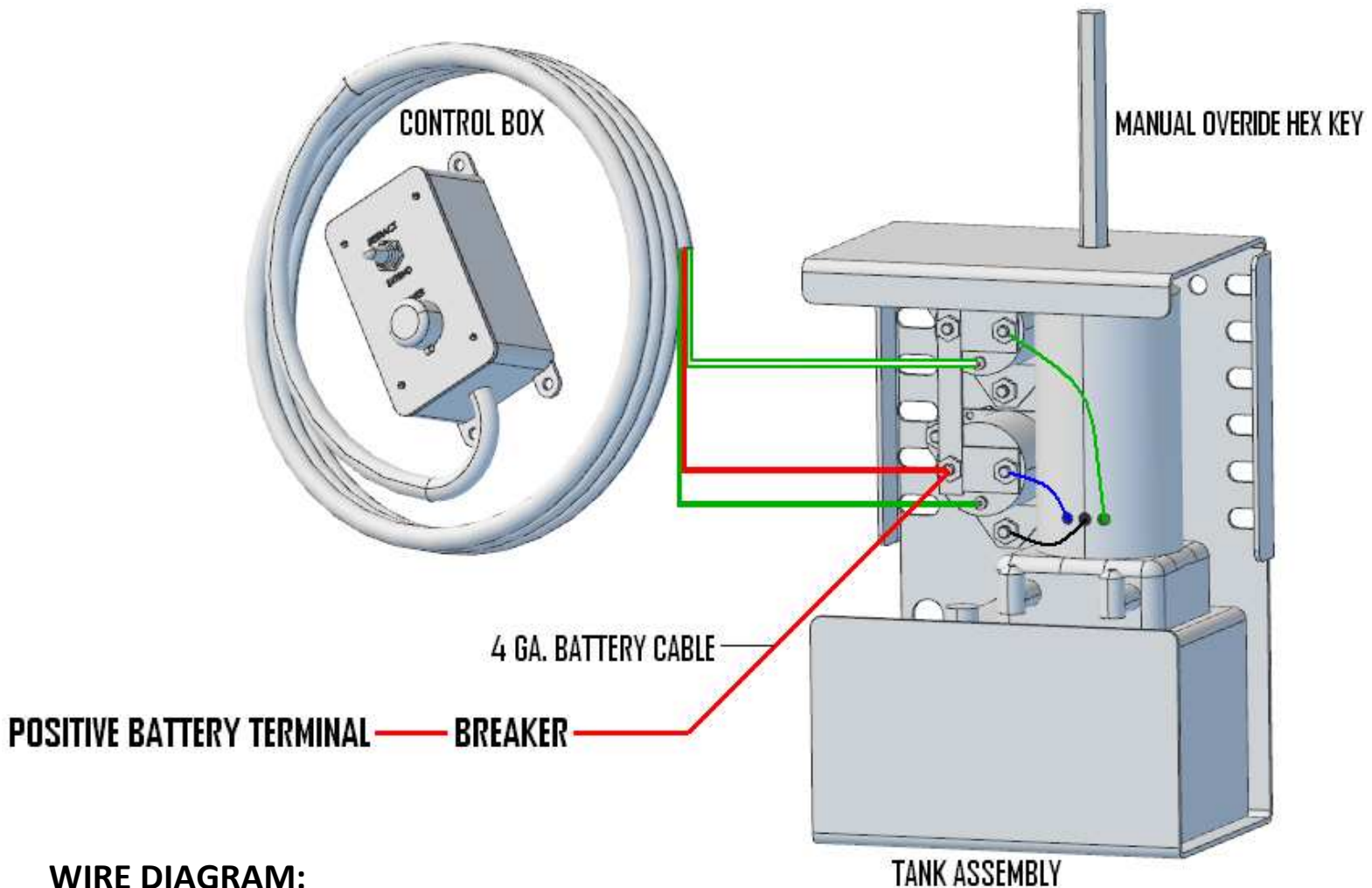

WIRE DIAGRAM:

- ▶ Green Wire attaches to lower solenoid stud.
- ▶ Red Wire attaches to bottom solenoid terminal over the copper strip.
- ▶ Red 4 Ga. battery cable attaches to same stud then goes to breaker then battery. (positive)
- ▶ Green/White Wire attaches to upper solenoid stud.

TROUBLE SHOOTING

“The jack runs for a few seconds, then stops”

- The battery is weak or the battery capacity has diminished.

“The jack only runs in one direction”

- Check battery voltage.
- Check all wire connections.

“I push the switch but nothing happens”

- Check both positive & negative 12V connections.
- Check for full charge of battery.
- Check that tank assembly has proper ground.
- Check wiring diagrams.

“The jack is jerky when retracting”

- There may be air in the system Fully extend both jacks leave for 30 minutes... Lower jacks.
- Low fluid level (Must be 3/4” below top of reservoir)
- Incorrect hose installation.
- To purge system, add necessary fluid and extend/retract leg a few times.

“Only one jack is working”

- Check the Yellow handle on the valve... it must be at a 45 degree angle to open the valve to operate both jacks.

The #1 issue is poor battery connection or power...

So check that first!

Otherwise give us a call!

(269) 483-9633

More Common Troubleshooting on the next page!

What Hydraulic Fluid do I use?

Automatic Transmission Fluid (ATF): Dexron II, Dexron III, ATF+4, Mercon, Mercon V

Panel won't turn on, system won't run, clicking noise...

Battery low, panel won't turn on = coach battery, the rest of system relies on house battery. The battery needs to be 100% charged for the system to work, it doesn't make a difference if the coach is new, that doesn't mean the battery is fully charged or even good. Batteries don't charge instantaneously, so one can't just expect to hook it up to a charger and the system will work immediately, they can un-plug/re-plug their battery gauges to show the true charge.

If the battery does for sure sound good, then the unit might have a ground issue.

Cylinders won't retract...

Broken/crushed limit switches, bent or broken clevis pins (especially rear jacks on fifth wheel)

Limit Switch barrels mounted too low, 1" is bad, 1 1/8" is good (Manufacturing defect).

Need new Limit Switches, Clevis pins & Limit Switch Washers (one of each per cylinder).

Medium Tank Assembly (Plastic Reservoir)

Plastic Foaming of fluid or overflow in reservoir....

- Check fluid level of reservoir with legs retracted (should be 3/4"-1" below top).
 - Rear jacks on fifth wheel?... Does it have red caps?... Send Blue Caps
 - The blue cap might be down too far into the hole of the reservoir... This blocks the air ventilation and causes the fluid to foam or overflow... Most of the cap should be sticking above the hole; it just needs to be "snug".
-

Cylinders *(Prior to 2008, cylinders only have 5 year warranty)*

Cylinders "creep" down when not in use... Check fluid level, OR Bleed System (air in the system)

Cylinders make loud "squeaking" noise while operating... Spray rams with Teflon spray (or dry lubricant).

Hydraulic Fluid on footpad or on ground around cylinder... Loose fitting or broken hydraulic line.

Cylinders "creep" down or don't hold pressure when lifting/holding coach...

- Check fluid level
- Check for leaks in hydraulic lines/fittings... if lines damaged, have them measure and order replacements from Quadra
- Possibly plumbed backwards... (Bottom port on cylinder tube should connect to right port on pump)
- Relief Valves have failed on pump motor... replace motor/return it to Quadra
- Hydraulic seal failure, check for oil around bottom of cylinder... replace/return cylinder OR seal kit

Warranty Guide

1 & 2pt Square Leg Systems:

Limited 5 years cylinders, 2 years on parts and 1 year on labor.

Should the product be defective due to workmanship and/or material flaw, we will repair or replace the defective material.

Quadra is NOT responsible for:

- **Freight on warranty parts.**
- **Replacing footpads, bolts, or fluids lost as a result of failure to maintain the system (Loose footpads should be tightened at owner's expense).**
- **Damages caused by abuse, misuse, negligence, misapplication, error of operation, accidental or purposeful damage or faulty installation. Including but limited to hoses, fittings & wiring components.**
- **Liability for loss to the vehicle, or apparatus or property, loss of time, manufacturing costs, labor, material, loss of profits, consequential damages (direct or indirect).**
- **For transportation to and from a service center, onsite service calls to or from the customer, damage from road hazard, loss of salaries, commissions, lodging, towing charges, bus fares, car rentals, fuel expense, telephone charges, inconvenience compensation while repairing or replacing a defective part or material.**

This warranty voids all previous issues. Effective date: 9/1/11

**OWNERSHIP MUST BE REGISTERED WITHIN 30 DAYS FROM THE DATE OF PURCHASE TO
ACTIVATE WARRANTY.**

Prior to any work being done an **authorization number must be obtained** by calling 269-483-9633 for Warranty Parts or Service Labor. For full warranty transcript just contact us!

Service labor based on a flat rate schedule determined by Quadra for **authorized** work performed will be reimbursed. This will eliminate much diagnostic time and avoid **refusal of unauthorized claims**. Many problems may be resolved by contacting a Quadra service representative.

Credit card payment arrangements at time of order will be nullified upon our receipt of your defective parts. **All returned parts need to have the repair authorization number** and be received within 30 days of original order to avoid charges.

Provide the system serial number here _____.

Emergency Service

For after hours emergency service please call our normal office number

269-483-9633 and follow the instructions.