



Installation Instructions

Rear Trac Bar - Part # SS301U

**This product reduces the side shift of the rear axle on Chevrolet/Workhorse
P-30
With rear drum brakes.**

Installation time is 1 to 2 hours.

***Some exhaust and/or brake line modifications may be necessary and extra.**

- **A qualified mechanic should perform installation of this product using normal automotive tools and following all known safety measures.**
 - **Exhaust should exit ahead of rear wheels to provide adequate clearance.**
 - **The Exhaust Kit SS300TP is available to relocate for proper clearance.**
 - **The SuperSteer® Rear Trac Bar is designed to be mounted with the axle bracket on either the driver or passenger side with the frame bracket on the opposing side of the axle bracket.**
 - **Typical installations have the axle bracket placed on the driver side with the frame bracket on the passenger side. Chassis that have large spacer blocks or wedges on the driver's side spring pack may not have enough U-bolts protruding for proper installation. In these cases, the SuperSteer® Trac Bar axle bracket may be mounted on the passenger side of the axle with the frame bracket on the driver's side or utilizing the longer U-bolts supplied in this kit.**
- 1. Move the coach to a level, flat surface. Drive the coach onto approximately 4" blocks. Set the brakes. Or you may drive the coach over a work pit and chock the front wheels. Block off adequate space at the rear of the coach to work.**
 - 2. Measure U-Bolt length extending past OEM nuts, which should be at least 1 1/2" long. If the U-bolts are of this length, do not remove the four (4) nuts on the rear axle U-bolts, but apply the axle bracket onto the U-bolts to verify enough threads to install the nuts. Attach the axle bracket with the supplied lock-nuts. Torque to 140 ft. lbs. (SEE FIGURE 1, next page). U-bolts must protrude through the lock-nuts by at least two threads. If U-bolts do not protrude by at least two threads, install the new U-bolts provided in this kit.**
 - 3. Install the frame bracket and nut plate to the frame rail. The frame must be between the nut plate and Rear Trac Bar frame bracket. The Rear Trac Bar frame bracket is designed to mount to the bottom and sides of the frame rail. Position bracket directly next to the rear frame cross-member (place nut**

plate with lip facing down and towards center of vehicle). Make sure not to contact any wires, brake lines, etc.

Part #SS301U – Installation Instructions

4. Then install the jam nuts onto the ½-20 bolts and install on the frame bracket. Tighten to push the nut plate against the inside of the frame, then tighten the bottom bolts securely (SEE FIGURE 1).

FIG. 1

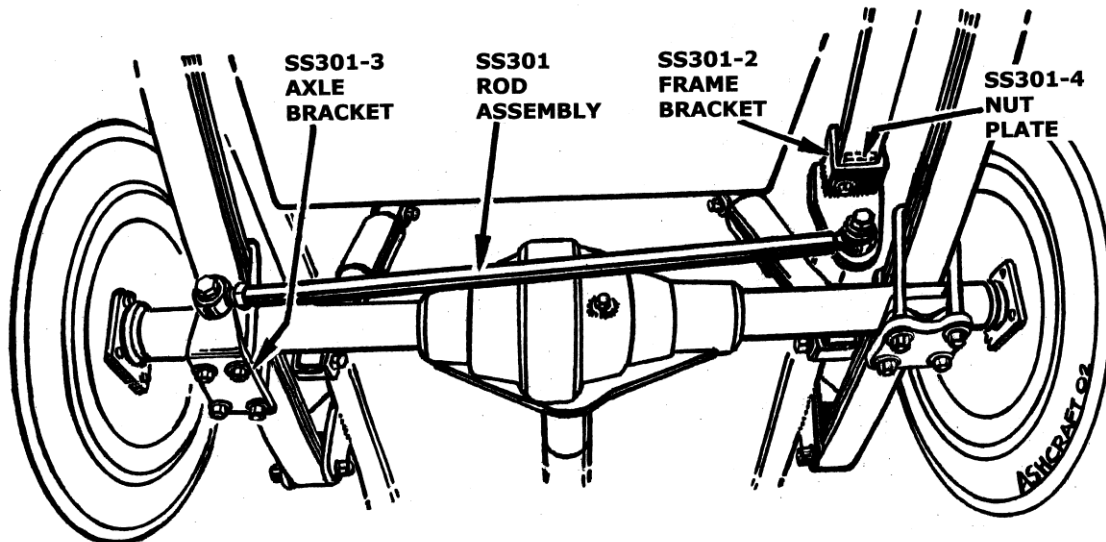

NOTE: USE SS301-5 BOLT KIT

SS301 TRAC BAR ON
P30 CHASSIS

5. Adjust and mount the Rod Assembly (Rod Assembly attaches to the rear of the brackets). Install bolts, washers and nuts. (Flat washers go on each side of bushings.) Torque to 120 to 150 ft. lbs.
6. Note: When adjusting the length of the Rod Assembly, it is necessary that the coach's full weight be on the suspension.
7. Tighten the Rear Trac Bar jam nuts to 100 to 150 ft. lbs.
Note: The Trac Bar should be below the rubber brake hose. Protect brake hose with convoluted tubing to prevent rubbing or possible failure.
8. Double-check fasteners, to make sure all are securely tightened.
9. Test drive. Complete and mail the warranty card.

Your comments are greatly appreciated. Please feel free to contact SuperSteer® at 888-898-3281 or e-mail at john@supersteerparts.com

Thank you for your purchase of the SuperSteer® Rear Trac Bar.