

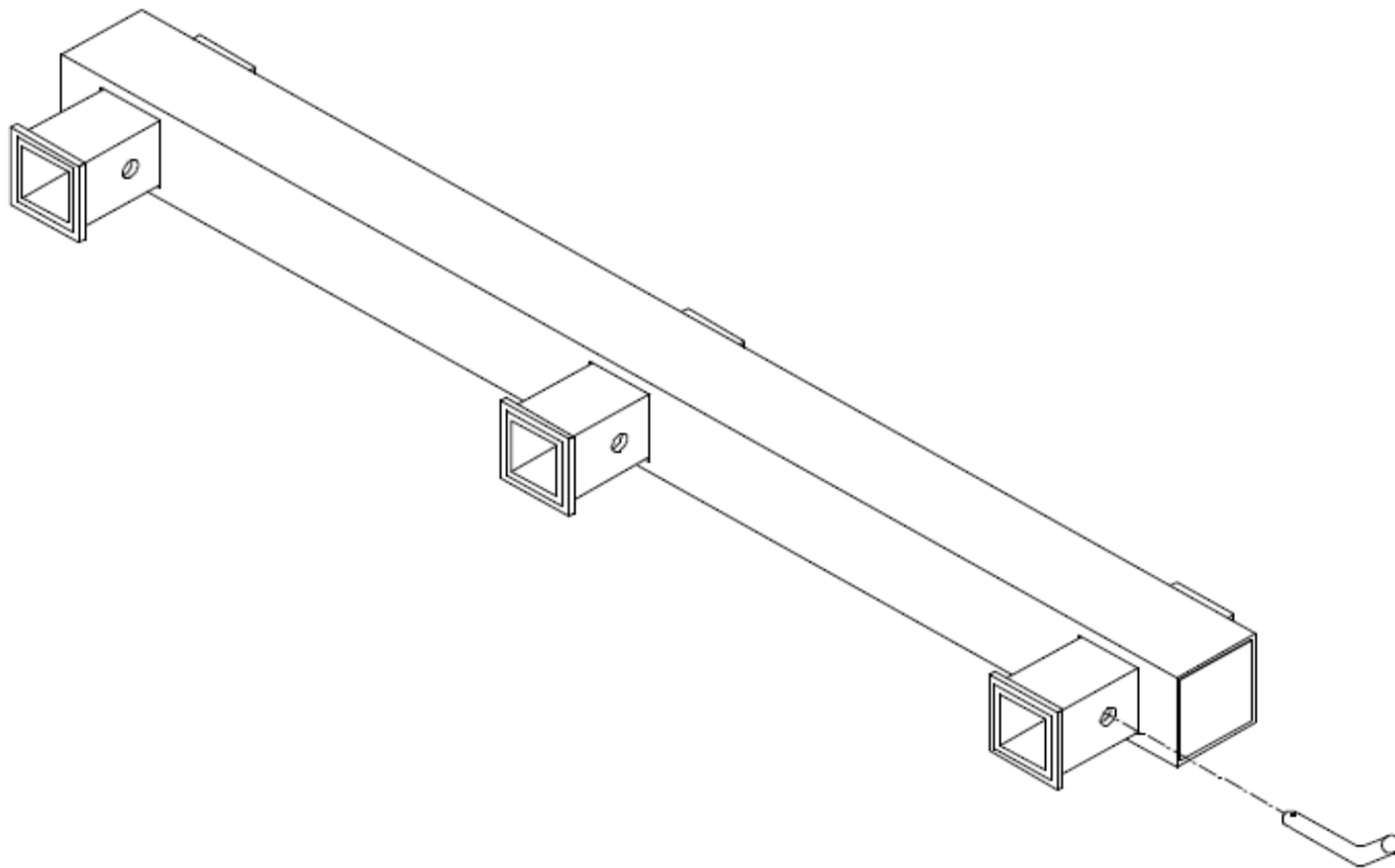

Strong As An Ox™

RECEIVER HITCH



Operator, Parts and Installation Manual

SC9000 Receiver Hitch SC9019 Receiver Hitch



Strong As An Ox™

IMPORTANT NOTES BEFORE INSTALLATION:

- Be sure to read the "Lift & Carrier Compatibility Information" to figure out if the lift or carrier is applicable onto the motorhome chassis and to figure out how much weight will be added to the rear axle of the motorhome.

- Installation of the receiver may require modification of mount plates or fabrication of new mount plates depending on the coach and chassis. Welding the mount plates to the 3 receiver weldment is also required:

- Use 3/8" to 1/2" hot rolled plate depending on application when fabricating the mount plates.

- Installers be aware of the rear exhaust of the RV when designing the mount plates, so the lift of carrier clears the exhaust when in operation.

- There should be six 3/4-10 hex bolts used on each mount plate.

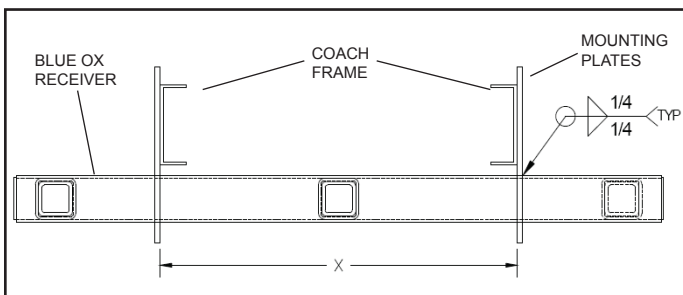

Fig. A

- The mount plates should be mounted directly to the main C-channels of the RV chassis for the most support.

- The hitch receiver needs to be welded by a certified welder.

INSTALLING HITCH RECEIVER

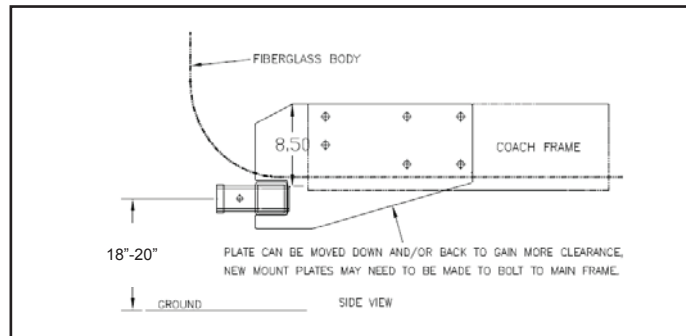

Fig. B

1. Note 1: If the original hitch has motor mounts incorporated into it, don't touch original hitch, the mount plates will have to go around it.

Note 2: The original hitch of the coach will need to be replaced with the SC9000 or SC9019 hitch receiver. Once the original hitch is removed, measure between the two c-channels of the frame of the coach. What ever this measurement is, is what the distance between the mounting plates need to be as shown in Fig. A. The hitch receiver needs to be positioned so the brackets of the lift or carrier will not hit the coach bumper or fiberglass body or exhaust pipe. (Fig. B). The recommended height of the Blue Ox receivers is 18-20 inches from the ground to the center of the receivers. The brackets can be pinned into the hitch receiver to give a better idea where the mounting plates need to be located. **Note: It is recommended that the 3 receivers have a 2 degree tilt up when welding or bolting the mount plates to the chassis. This will make sure the deck is level once cargo is loaded onto deck.** Bolt the hitch receiver assembly to the c-channels of the coach with 3/4-10 x 1 3/4 hex bolts, lockwashers, and hex nuts.



Strong As An Ox™

Parts List

| Ref. No. | Qty. | Part No. | Description |
|----------|------|----------|-------------------------------------|
| 1 | 1 | 61-5864 | Wldm't, Hitch (SC9000 & SC9019) |
| 2 | 2 | 101-6449 | Mounting Plate |
| 3 | 12 | 201-0286 | 5/8-11 x 1 3/4 Hex Bolt, GRD. 5, ZP |
| 4 | 12 | 202-0008 | 5/8-11 Hex Nut, ZP |
| 5 | 12 | 203-0013 | 5/8 Lock Washer, ZP |
| 6 | 3 | 200-1483 | Pin, 5/8 x 3 eff. w/clip |

Note: The SC9019 weldment doesn't require any mounting plates.

