

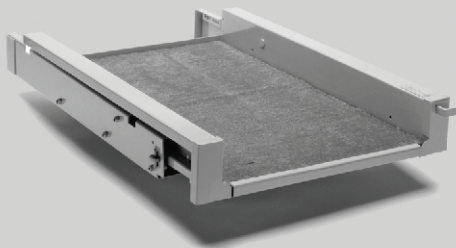

Super Slide™ Installation

© 2/04 Kwikkee Products Co., Inc.
Kwikkee #1421100 Rev. 2 2/04



Super Slide™ Installation Instructions

READ ALL INSTRUCTIONS CAREFULLY BEFORE STARTING

SUPER SLIDE ASSEMBLY

- 2 Slide assemblies (1 left, 1 right)
- 2 Base brackets (1 left, 1 right)

TRIM PIECES*

- 1 Front support bracket (U-channel)
 - 1 Rear support bracket (L-bracket)
- * 2-way pull uses 2 U-channels

OTHER HARDWARE AND PARTS

(NOT INCLUDED: Quantity of hardware and size of deck material vary by installation)

- 1 3/4" plywood deck, cut to fit application
- 5/16"-18 carriage bolts
- 1 Carpet or other material to cover plywood for deck (optional)
- 5/16"-18 carriage bolts (length depends on mounting surface thickness)
- 5/16" flat washers
- 5/16" split lock washers
- 5/16" 18 hex nuts
- 1/4" pan-head wood screws

- SuperSlide consists of seven component parts, 2 (left and right) base brackets, 2 (left and right) slide assemblies, 1 front U-channel*, 1 rear L-bracket*, 1 deck (constructed of 3/4" plywood and carpet, not included)
- * 2-way pull SuperSlides use 2 U-channels
- Make sure that all component parts and hardware listed are available before continuing installation.

- Set the base brackets in the compartment, positioning them a minimum of 2 1/2" back from the inside of the compartment door or door hardware if applicable.) Align both left and right base brackets in a squared parallel configuration as shown in **Figure 1**.

- Mark the locations of the square mounting holes, remove the base brackets and drill the mounting holes with an 11/32" diameter drill bit. Use 5/16"-18 carriage bolts, flat washers, lock washers, and hex nuts (not included) and securely bolt the base brackets in place.

- The depth of the deck is set by the vertical flanges on the slide assemblies. The width of the deck is determined by measuring the distance inside the vertical flanges on the base brackets and subtracting 2 1/2". Use the holes in the slide component horizontal flange to attach the deck.

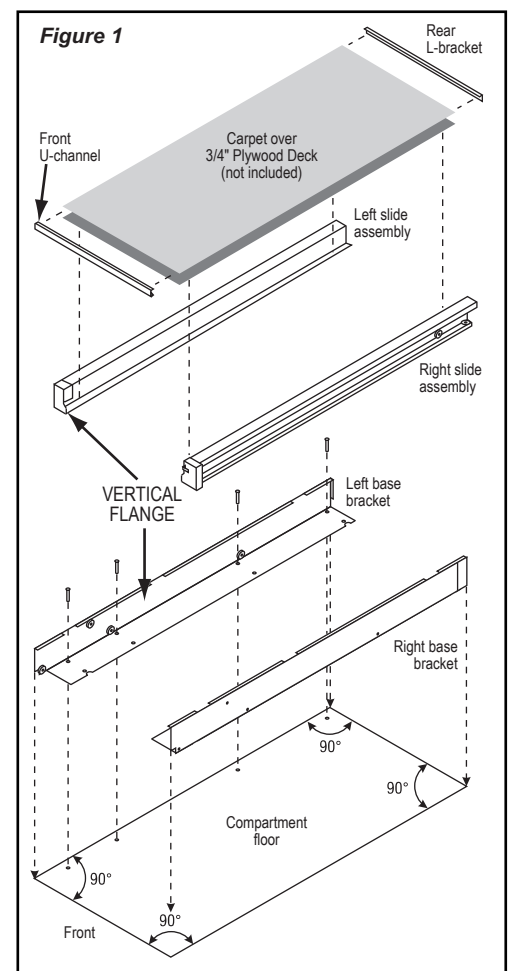

- Attach the front U-channel and rear L-bracket to the deck using pan-head screws and the holes provided. The 2-way pull SuperSlides use U-channel on front and rear.

NOTE: If compartment opening has a lip on the bottom edge which is greater than 3/4", it will be necessary to construct plywood spacers to raise the base brackets and allow clearance for slide extension. Make spacers the same dimension as the base bracket horizontal flanges.

Slide length determined by compartment depth.

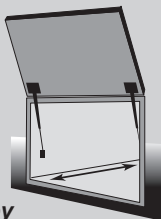

Slide width determined by width of deck installation.

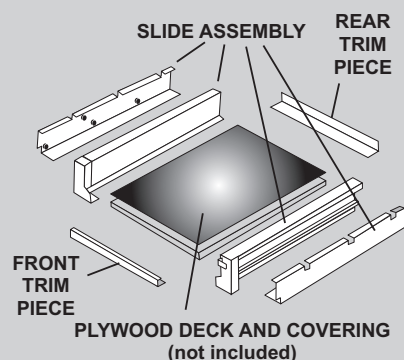

6. With the deck installed, you are ready to slip the completed slide assembly into the base brackets that have been secured to the compartment floor. Position the 1" square tube located on the outside of the slide assembly on top of the slide support bearings. (See Figure 2.)

Occasionally pull the latch release as the slide goes in so the latch bearing will clear the upper flange of the base bracket and the latch stops. Lift the front of the assembly slightly to gain clearance for the roller guide and roller bearing.

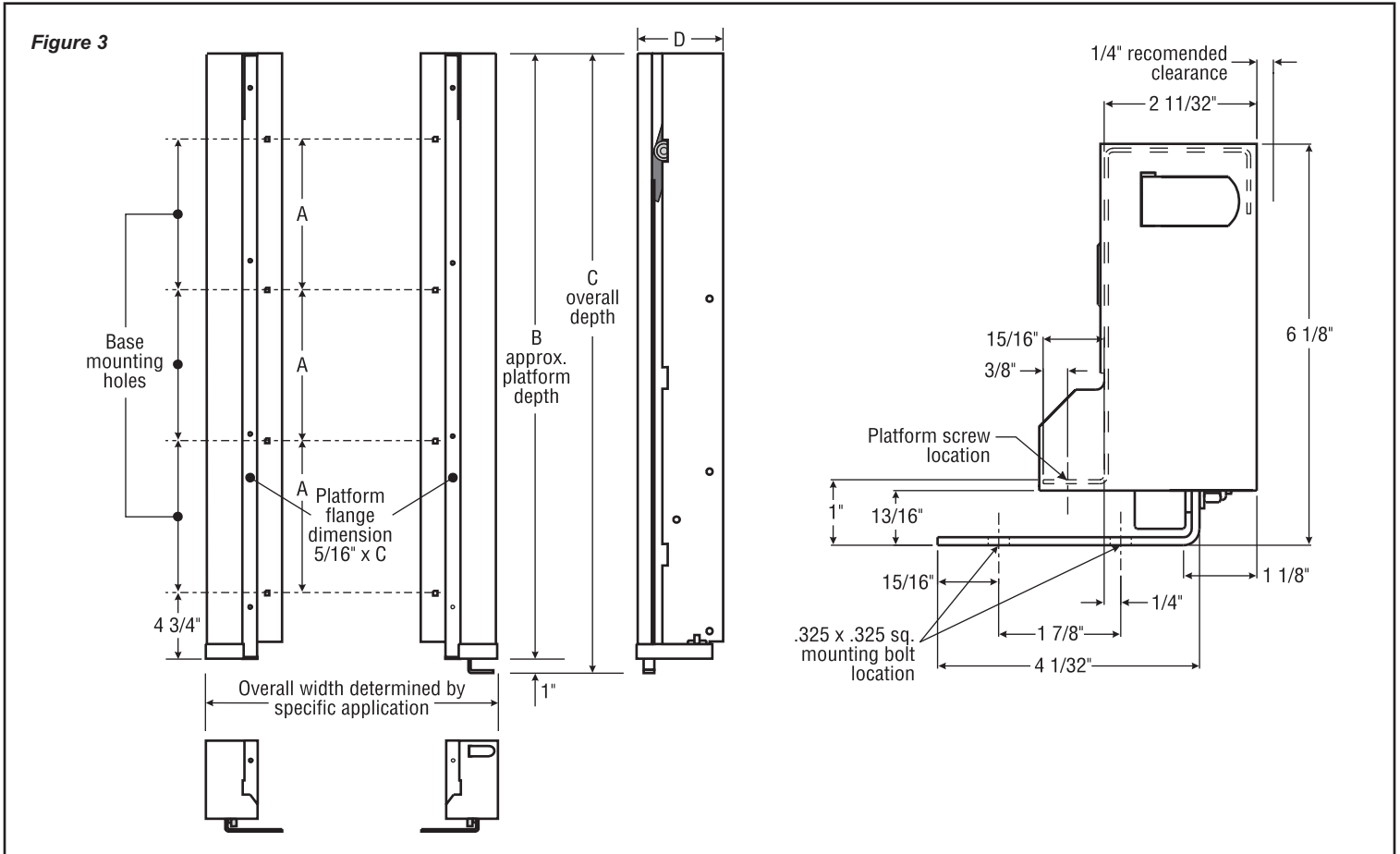
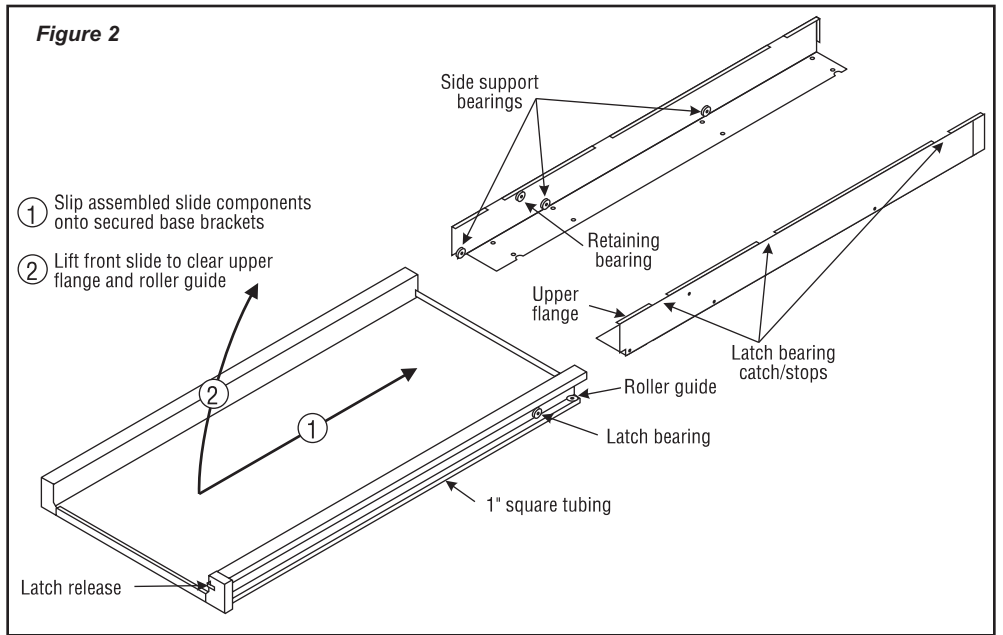

NOTE: Maximum weight capacity: 1,000 lbs. distributed evenly.
CAUTION: If operating the slide assembly when vehicle is not level, use caution.