

# BAL Hide-a-Spare Installation Instructions

Before installing, be sure to review placement on trailer frame and inspect for potential obstacles. Consider the locations of the entry step, slide room components, electrical or LP or plumbing lines, waste tanks and outlets. You will need open area on both sides of the trailer for the Pivot Bracket (A) and the Storage Bracket (B). Mounting the carrier closer to the axles offers less of a chance of ground clearance issues. You can mount the carrier to either side of the trailer based on your preference and frame limitations.

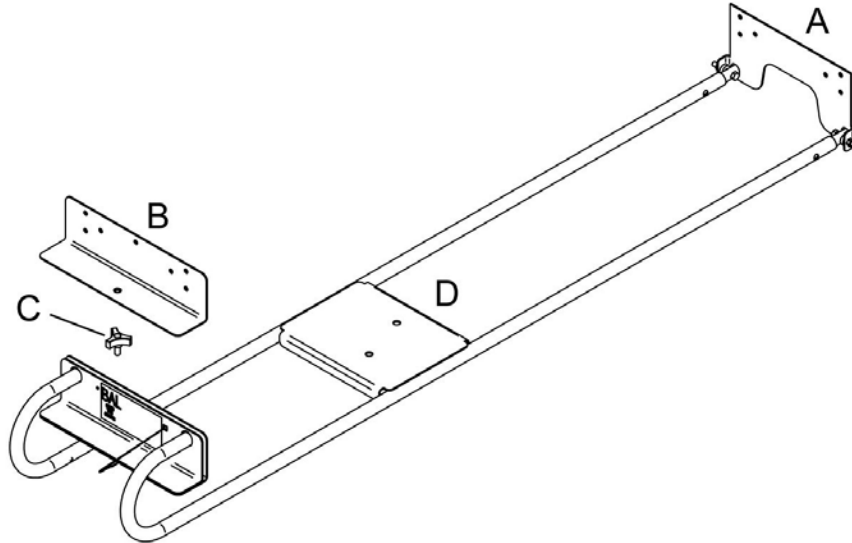

- 1) After determining the location for the Hide-a-Spare, use the Pivot Bracket (A) as a template for marking the screw locations. If you are installing a Hide-a-Spare on a trailer without enclosed underbelly, you will mount the Pivot Bracket on the interior of the frame rail. Trailers that have enclosed underbellies will mount on the exterior of the frame rail. Depending on your frame, pre drill for bolts (minimum of 2 bolts 5/16" diameter X proper length required) and you can also use self tapping screws for extra support. Before drilling or using self tapping screws to mount Pivot Bracket, make sure you will not be damaging any electrical, LP, or plumbing lines. If there are obstructions, either relocate the Pivot Bracket or move obstacles.
- 2) Once the Pivot Bracket is securely mounted to the frame, move to the opposite frame rail and temporarily lift the Hide-a-Spare up to the frame. Measure the distance between the bottom of your trailer floor or enclosure to the Spare Tire mount location (D). Compare this measurement to the width of your spare tire. If there is not enough clearance, you will need to lower the Hide-a-Spare's Storage Bracket (B) to a location on the exterior of the frame rail to increase the clearance to accommodate the spare tire. After determining the proper location, use the Storage Bracket as a template to mark the bolt/screw locations just as you did with the Pivot Bracket while considering all obstructions.
- 3) Now that the Storage Bracket is securely fastened to the exterior frame rail, lift the Hide-a-Spare up and over the Storage Bracket and align the hole for the plastic Locking Knob. Insert the Locking Knob (C) thru the two holes and insert the Cotter Pin to keep Knob in place. Stretch the Lanyard attached to the Locking Knob out to a location on the Hide-a-Spare plate or to the trailer frame that you can secure the Lanyard with a self tapping screw.
- 4) Remove the Locking Knob and drop the Hide-a-Spare to the ground. Telescope the carrier away from the trailer by pulling outward. Once the mount location plate (D) is accessible, place the spare tire on the carrier and fasten with included bolts. Push the carrier back into place under trailer and lift up to secure to Storage Bracket as done in Step 3.