

STOWMASTER™

Installation Instructions

Tow bar rated
at 6,000 pounds

851030-07 04/11

All specifications are subject to change without notice.

ROADMASTER, Inc. 6110 N.E. 127th Ave. Vancouver, WA 98682 800-669-9690 Fax 360-735-9300 www.roadmasterinc.com

**Owners and installers
must read the installation instructions
and carefully note the warnings!**

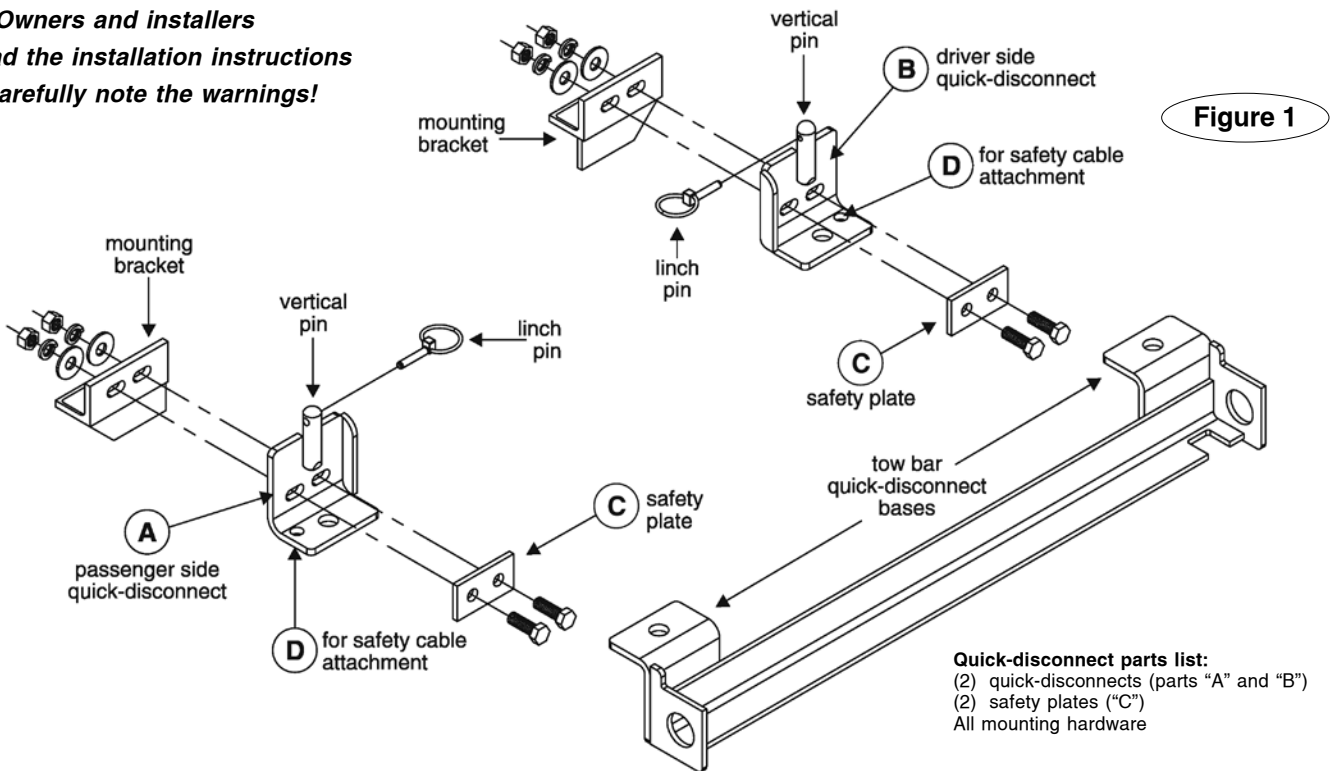

Installing the 'quick-disconnect' system

This tow bar is equipped with a "quick-disconnect" (or, "QD") system. Before connecting the tow bar to the vehicle, first install the components of the QD system to the mounting bracket.

1. First, attach the quick-disconnects ("QDs," parts "A" and "B" in Figure 1) to the tow bar mounting brackets. Attach the QDs so that the vertical pin on each is pointing up, as shown in Figure 1.

Attach part "A" on the passenger side, and part "B" on the driver side. Use the supplied ½" x 1¼" bolts, the two safety plates (parts "C"), and the flat washers, lock washers and nuts, as shown in Figure 1.

Note that both QDs have an extra hole – "D" in Figure 1 – for safety cable attachment. Mount parts "A" and "B" so that the "D" holes are to the outside.

Do not tighten any of the bolts – leave them loose for now – they will be tightened later.

WARNING

Use all mounting hardware and both safety plates. If all supplied materials are not used, the quick-disconnects, the quick-disconnect bases or other components may vibrate loose, which may cause property damage, personal injury or even death.

2. Now, test-fit the crossbar – lower the crossbar (Figure 2) over the quick-disconnects. The vertical pins at the top of both QDs should fit through the top holes at the ends of the crossbar (Figure 2), and the vertical pins at the bottom of the crossbar should fit through the lower holes on the quick-disconnects (Figure 2).

3. Both quick-disconnects must be positioned so that the crossbar is centered to the front of the vehicle – measure the distance between the side of one QD and the side of the mounting bracket it is attached to. Then, make certain there is an equal distance between the other QD and the other mounting bracket.

CAUTION

The quick-disconnects must be centered on the mounting brackets.

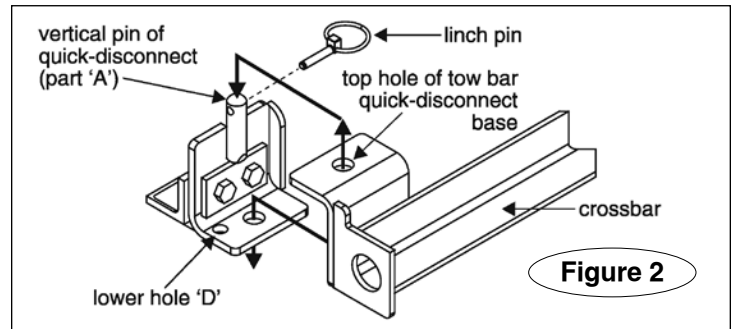

If they are attached too far to the left or the right, the tow bar will not be centered on the towed vehicle, which will cause excessive tire wear and other consequential, non-warranty damage.

4. Once the crossbar slides on and off easily, torque the four bolts to 75 ft./lbs.

Again, test-fit the crossbar over the QDs, to verify that the crossbar slides on and off easily. If it does not, adjust the QDs again.

5. Both lynch pins must be inserted through the upper holes in the vertical pins in parts "A" and "B," as shown in Figure 2.

Both lynch pins must be locked. The rings (Figure 4) are spring-loaded – they must be snapped over the pins, as shown in Figure 4, with the curved side of the lynch pin touching the ring, in order to keep the QD bases secure.

WARNING

Towing vibrations will force the lynch pins out unless they are properly locked in place over the vertical pins on both quick-disconnects. Refer to Figure 4.

Failure to properly attach and lock both lynch pins will result in the loss of the towed vehicle, which may cause property damage, personal injury or even death.

Installer's safety checklist

- **The installer must be sure that the vehicle is suitable or adaptable for towing.** Some vehicles must be equipped with a transmission lube pump, an axle disconnect, driveline disconnect or free-wheeling hubs before they can be towed. Failure to properly equip the vehicle will cause severe damage to the transmission. Check the manufacturer's instructions for the proper procedure(s) to prepare the vehicle for towing.
- **Read the instructions thoroughly before installing the 'quick-disconnect' ('QD') system and its components.** The tow bar will be attached to the QD system. If the QD system is not properly aligned, centered and positioned on the towed vehicle, the tow bar will not be centered on the towed vehicle, which may cause excessive tire wear and other consequential, non-warranty damage.
- **Stress to the owner that the tow bar must be level with the ball hitch on the motorhome.** Towing with the tow bar at an upward or downward slope puts undue strain on the tow bar mounting bracket and the ball mount. Driving over sharp inclines or declines could force the coupler off the hitch ball. (For the StowMaster 581 pintle hook tow bar only, the tow bar must be no more than three inches above or below level.)
- **Show the owner how to properly operate the tow bar.** Familiarize yourself with the features of the tow bar. Demonstrate them to the owner, and ask the owner to connect and disconnect the tow bar and other components of the towing system, until the owner is comfortable with its operation.
- **Advise the owner to always use safety cables when towing.** The safety cables must connect the towed vehicle to the towing vehicle, frame to frame. **The weight capacity of the safety cables must meet or exceed the towed weight, or the safety cables will fail.**
- The StowMaster tow bar is rated at a maximum of 6,000 pounds carrying capacity; therefore **the weight of the towed vehicle and all its contents cannot exceed 6,000 pounds.** In addition, the hitch ball, the receiver hitch, the safety cables and all supplementary towing equipment must be rated at no less than the weight of the towed vehicle and all its contents.
- **Caution the owner to use a hitch ball with a two-inch diameter.** If the hitch ball diameter is smaller than two inches, the coupler may disengage during towing. In addition, the diameter of the threaded hitch ball shank must match

- the diameter of the hole size in the ball mount hitch. If the threaded hitch ball shank is too small, towing vibrations could cause the hitch ball to unthread and separate from the ball mount hitch.
- **The tow bar must be attached to a bracket which is bolted to the towed vehicle's frame or unibody.** In order to be towed, virtually all vehicles require a tow bar mounting bracket that is connected to the frame, unibody or chassis and extends beyond the bumper.
- **The tow bar must be mounted upright, with the coupler facing out.** See Figure 3. Never mount the tow bar with the coupler facing any other way – the tow bar arms and other components will be severely damaged during towing.
- **Caution the owner to secure the tow bar with linch pins (or optional padlocks) before towing.** Unless the tow bar is secured to both vehicles with all appropriate pins (or padlocks), the towed vehicle will detach.
- **The installer must NOT use the tow bar as a ground for welding.** Connecting a ground to the 'A-frame' of the tow bar will cause current to flow through the locking spring, which will detemper the spring and destroy the locking mechanism.
- **Under no circumstances should the tow bar be welded to the vehicle,** nor should any of the pre-punched mounting holes be altered. Any welding or altering of the tow bar will void the owner's warranty.

WARNING

Failure to follow these instructions may cause property damage, personal injury or even death.

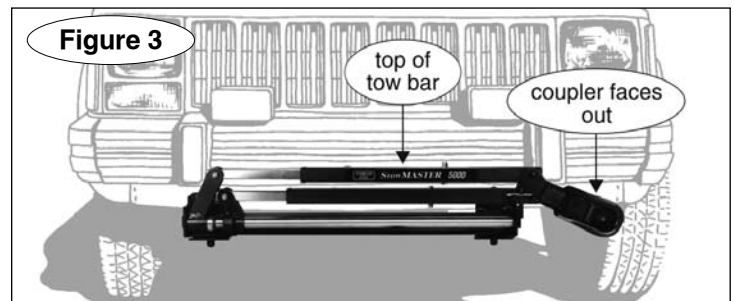

Connecting and disconnecting

CAUTION

Use caution when handling the tow bar – if your hands, fingers or any part of your body are caught between moving components, they can be pinched, cut or otherwise injured.

Connecting the tow bar

1. First, install the 'quick-disconnects' ("QDs") to the tow bar bracket, as described on the preceding page.
2. Next, attach the tow bar to the driver side and passenger side QDs – lower the tow bar over both QDs so that the vertical pins (Figure 2) extend upward through the top holes of the QD bases (Figure 2).
3. At the same time, make certain that the lower vertical pins of each QD base slide through the lower holes on both QDs (Figure 2).
4. The two linch pins (Figure 2 and 4) must be inserted through the upper holes in the vertical pins in both QDs.

Both linch pins must be locked. The rings (Figure 4) are spring-loaded – they must be snapped over the linch pin, as shown in Figure 4, with the curved side of the linch pin touching the ring, in order to keep the QD bases secure.

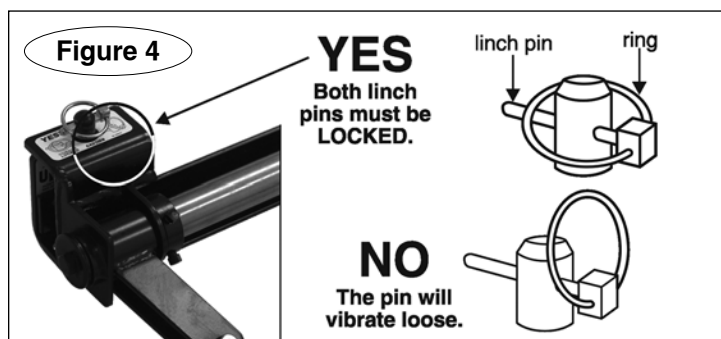

WARNING

Towing vibrations will force the linch pins out unless they are properly locked in place over the vertical pins on both quick-disconnects, as described above.

Failure to properly attach and lock both linch pins will result in the loss of the towed vehicle, which may cause property damage, personal injury or even death.

4. Drive the towed vehicle within three or three-and-a-half feet of the motorhome hitch receiver. The vehicle does not have to be perfectly centered to the hitch receiver, just close. Then, put the vehicle in gear (park), set the emergency brake and chock one of the wheels.
5. Pull the storage hairpin out of the groove on the stabilizer pin on the driver's side of the folded tow bar, and remove it.
6. Swing the tow bar up, in a counterclockwise direction, until it is fully extended. Then slide the driver's side arm to the extreme right side of the stainless steel slider bar.

CAUTION

Never release the tow bar arms when they are in the vertical position. The arms can fall and cause severe personal injury.

7. Lower the tow bar to position the coupler over the hitch ball. Slide the tow bar arms forward or backward, as needed, to maneuver the coupler over the hitch ball. If one of the tow bar arms does not slide forward or backward, press down on the Autowlok button to unlock it.
8. With the coupler over the hitch ball, raise the coupler locking lever (Figure 5) until the tab 'ear' (Figure 5) just clears the tab hole (Figure 5), and pull straight back toward the towed vehicle.

Now, lower the coupler over the hitch ball so that it completely covers it, and slide the coupler locking lever forward until it locks on the ball.

continued on next page

Connecting the tow bar

continued from preceding page

Note: an optional coupler lock (part number 305) is available for added protection against accidental coupler disconnect.

Be certain the coupler is properly locked onto the hitch ball. The tab ear will slide back into the tab hole when the mechanism is fully engaged.

WARNING

If the coupler is not properly locked onto the hitch ball, as described above, it will release during towing. The tow bar will separate from the motorhome, which may cause property damage, personal injury or even death.

9. Attach the safety cables (See "Proper installation of safety cables" and "How to use safety cables" in these instructions) and plug in the electrical wiring cord, according to the supplier's instructions.

Before towing the vehicle, make certain that the steering is unlocked, the transmission is in the proper setting, and the emergency brake is released.

Remove the wheel chock.

Check the manufacturer's specifications and the owner's manual for the proper towing procedures or requirement(s) for the vehicle to be towed.

WARNING

Do not tow the vehicle until the tow bar is properly attached with all pins or padlocks. Unless the tow bar is secured to both vehicles with all appropriate pins or padlocks, the vehicle will detach, which may cause property damage, personal injury or even death.

When you drive away, steer briefly to the left and then to the right, to extend, self-center and lock the tow bar.

Always stop at this time. Check the tow bar to ensure that both arms are locked, before assuming highway speed. Additionally, check the other components of your towing system, to ensure that they are fully engaged.

WARNING

Both tow bar arms must be locked before towing. If they are not, the momentum of the towed vehicle will apply excessive force to the tow bar arms and other components of the towing system, which may cause the towing system to fail, resulting in property damage, personal injury or even death.

WARNING

The tow bar arms will not automatically lock if the Autowlok buttons are missing or damaged. While the arms can be locked manually without the buttons, it creates the potential for tow system damage and separation of the towed vehicle, should you forget to do so. For this reason, replace missing or damaged Autowlok buttons immediately.

Failure to follow these instructions may cause property damage, personal injury or even death.

WARNING

Do not tow a vehicle using tow bar mounting brackets, safety

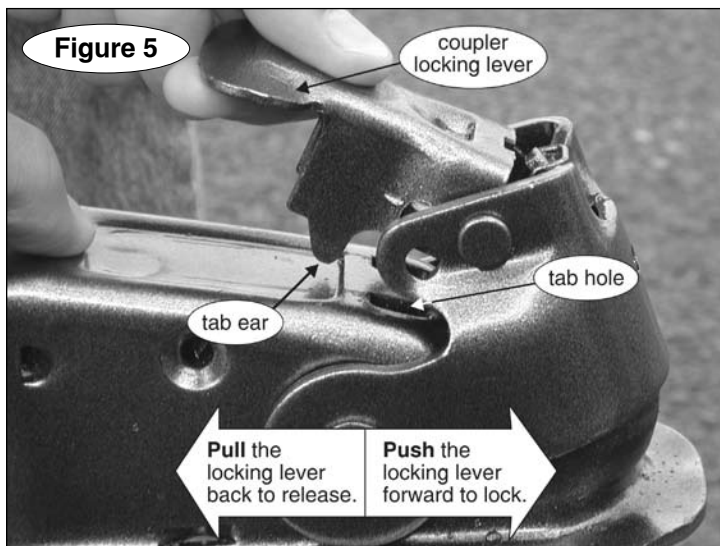

For the pintle hook tow bar...

...disregard references to the coupler, ball mount and related accessories. With this exception, follow all instructions and safety warnings in these instructions.

The tow bar may be used with most pintle hooks accepting a lunette ring with a 2½" inner diameter. The pintle hook must have a weight capacity equal to or exceeding the towed weight; follow the manufacturer's recommendations as to suitability for this application.

During towing, the pintle hook tow bar must be no more than three inches above or below level.

To connect and disconnect the tow bar, follow the pintle hook manufacturer's instructions.

cables, or a hitch receiver rated less than the actual weight of the towed vehicle.

If the brackets, safety cables, hitch receiver or any supplementary towing equipment is not rated at the weight of the towed vehicle and all its contents, it may fail during towing, causing property damage, personal injury or even death.

Disconnecting the tow bar

1. Disconnecting the tow bar is essentially the reverse of connecting it. Before you begin, always...

- ...try to park on level ground, with the towed vehicle in line with the motorhome; and
- ...turn the towed vehicle's steering wheel until the front wheels are in line with the motorhome.

This will eliminate most of the tension between the two vehicles, allowing for an easier disconnect.

2. Disconnect the electrical wiring harness, safety cables and any other towing system accessories.

3. Put the towed vehicle in gear (park), set the emergency brake and chock one of the wheels.

WARNING

Always put the towed vehicle in gear (park), set the emergency brake and chock one of the wheels before lifting the coupler off the hitch ball. Failure to do so may result in a 'runaway' vehicle or may crush you between the towed vehicle and the motorhome, causing property damage, personal injury or even death.

4. Pull back on the coupler locking lever (Figure 5) to release the coupler, and lift the coupler off the ball.

Note: if it is difficult to lift the coupler, the towed vehicle's weight may be pressing against it. Release the pressure by pushing down on one or both of the Autowlok buttons to unlock them.

If the Autowlok button(s) will not release, turn the towed vehicle's steering wheel as far as it can go to the left or right, then in the other direction. Then straighten out the steering wheel until the front wheels are in line with the motorhome.

CAUTION

Never use a hammer or mallet to disconnect the Autowlok buttons. This will drive the plastic buttons down the shaft, preventing the lock from releasing.

5. Lift the coupler up, until the tow bar is completely vertical. Push down on the Autowlok button on the driver's side arm, and allow the arm to compress.

Slide the driver's side arm to the extreme left side of the stainless steel slider bar, and lower the coupler onto the stabilizer pin.

Note: do not push the passenger side Autowlok button. Pushing only the driver's side button allows the tow bar to be lowered directly onto the stabilizer pin, without any adjustment.

6. To secure the tow bar, press the storage hairpin onto the groove in the stabilizer pin.

7. To remove the tow bar, remove the two lynch pins (Figures 2 and 4) at the top of both quick-disconnects, and lift the tow bar up and away.

(ROADMASTER recommends replacing at least one lynch pin with a padlock – part number 301 or 302 – to prevent accidental release or theft.)

CAUTION

Unless the storage hairpin is in place before the tow bar is removed, the base of the tow bar may fall, which may cause severe personal injury.

Do **not** run the safety cables between the hitch ball and the coupler. Use an optional **cable guide** (part number 669) to help prevent the safety cables and the electrical cord from being crushed or damaged, either between the coupler and the hitch ball, or between the ball mount and the road.

Connect the **snap hooks** to the steel loops on the hitch receiver or the frame of the motorhome.

Pass the safety cables through this loop – **DO NOT ATTACH THE SAFETY CABLES TO THE LOOP.**

Cross the safety cables under the coupler (Attach the ends of one cable to the driver's side of the tow bar and the passenger side of the motorhome, and vice versa.). This helps prevent the tow bar from hitting the road and "pole vaulting" if the tow bar separates from the hitch receiver.

Wind the safety cables around both tow bar arms to adjust for any excess slack. **The last pass must be to the inside**, to allow the towed vehicle to track in line behind the motorhome.

long safety cable
Use quick links for easy attachment and removal of the safety cables.

short safety cable
For double-hook safety cables – attach the second snap hook to a quick-link at the towed vehicle, as shown to the right.

Figure 6

How to use safety cables

Safety cables are an integral part of your towing system. They are a secondary safety device, required by law in many states. This section, and "Proper installation of safety cables" (on this page) will acquaint you with how to use them properly.

- The safety cables must be rated at 6,000 pounds weight capacity (the maximum capacity of the StowMaster tow bar). The weight of the towed vehicle and all its contents cannot exceed 6,000 pounds.
- The safety cables must connect the towing vehicle to the towed vehicle, frame to frame.
- Pull the safety cables so that all the slack is at the motorhome. **Make sure there is enough slack in the cables at the motorhome to allow for sharp turns** – if there is not enough slack, the towing system will be severely damaged when the motorhome turns.
- The safety cables must be the correct length...
 - Make sure the cables are not too short – if you use a receiver hitch extension or other equipment that extends the distance between the towed vehicle and the motorhome, the standard cables may be too short. If the cables are too short, the towing system will be severely damaged when the motorhome turns a sharp corner. (Safety cable extensions in a wide variety of lengths are available from ROADMASTER.)
 - Make sure the cables are not too long – the cables should not hang down to the extent they may catch on obstructions, or drag on the ground. This much slack could cause damage to the towing system, the towed vehicle, or the motorhome. If the cables are too long, wrap the excess cable around the tow bar to take up the slack. **Make sure there is enough slack in the cables at the motorhome to allow for sharp turns.** Damage caused by using safety cables of an incorrect length is not covered under warranty.
- Always cross the cables under the coupler, as shown in Figure 6 (above). In the unlikely event the tow bar separates from the motorhome, crossing the cables will help prevent the tow bar from dragging on the ground, which can cause the tow bar to "pole vault" the towed vehicle.
- Some ROADMASTER tow bar mounting kits with removable arms use two safety cables on each side. If two sets of safety cables are required, both must be used. This is required by law. Refer to "Proper installation of safety cables" (on this page) for further information.

WARNING

Failure to follow these instructions may cause property damage, personal injury or even death.

The StowMaster owner's manual...

...contains additional illustrations to accompany the "Connecting and disconnecting" instructions, as well as important safety information, the limited warranty, and other information to make your towing experience safe and pleasant.

Read the owner's manual cover to cover before towing a vehicle.

The ROADMASTER limited warranty...

...including full warranty text and the product registration card, is enclosed in the StowMaster literature package.

Proper installation of safety cables

Some ROADMASTER tow bar mounting brackets with removable arms, such as the ones in Figures 6 and 7, use both a long safety cable and a short safety cable on each side.

Each **long safety cable** runs from the towing vehicle to a **quick link** attaching it to one of the quick-disconnects. This quick link is also an attachment point for one of the **short safety cables**; another quick link attaches the short safety cable to the mounting bracket.

Unscrew the nuts on each quick link to connect the safety cable loops. Finger-tighten the nuts firmly, until the loop is completely closed, to secure the attachment.

Do not substitute carabiners or other devices for the quick links – the quick links are designed to hold the weight of a towed vehicle; carabiners or other devices are not.

Only ROADMASTER bracket kits with removable arms have these short safety cables (with the exception of MX brackets). Other bracket kits are bolted directly to the frame of the towed vehicle and do not require short safety cables.

If your ROADMASTER bracket kit contains short safety cables, refer to the installation instructions for complete information.

WARNING

The safety cables must be carefully routed so that they cannot become pinched, frayed, scraped or otherwise damaged, and so they will not drag when going over dips or low spots.

Do not use the cables if they show any signs of wear or damage – immediately discontinue towing and replace the cables.

Failure to follow these instructions will result in cable failure, which may cause property damage, personal injury or even death.

WARNING

If the quick links are not completely tightened, with the loop closed, the safety cables may detach. In the event of a towing system failure, the towed vehicle will detach, which may cause property damage, personal injury or even death.

WARNING

If your towing system requires two sets of safety cables, always use both the long and the short safety cables. Connect them as shown in Figures 6 and 7. Otherwise, in the event of a towing system failure, the towed vehicle will detach, which may cause property damage, personal injury or even death.

