



Time Tested • Time Proven

855408-01 10.15

Motorhome charge line kit
part number 156-75

Installation instructions

All specifications are subject to change without notice.

ROADMASTER, Inc. 6110 NE 127th Ave. Vancouver, WA 98682 800-669-9690 Fax: 360-735-9300 roadmasterinc.com

CAUTION

Read all instructions before installing or operating this device. Failure to understand how to properly install or operate the charge line kit could result in extensive property damage.



This kit requires...

- ...a 6-wire (or a 6-wire to 7-wire) power cord between the two vehicles with matching sockets; and
- ...a charge line kit similar in function to this kit in the towed vehicle. If a charge line isn't already present in the towed vehicle, order part number 156-25, the towed vehicle charge line kit.

Installation instructions

1. Attach one end of the included length of red 12 gauge wire to the charge line pin (the number 4 pin in Figure 1) in the motorhome's power cord socket.
2. Route the wire to the area of the positive battery terminal. Choose the shortest route that will avoid the possibility of a short circuit or other damage to the vehicle. The shorter the distance, the better the charge circuit will work.

Cover the wiring along its entire length with the included split loom.

WARNING

Route all wiring to avoid moving parts, sharp edges, the fuel lines or hot components such as the engine or exhaust systems. Use the included wire ties to secure the wiring out of the way.

Wiring exposed by moving parts, sharp edges or hot components may cause a short circuit, which can result in damage to the vehicle's electrical system as well as other, consequential damage.

Wiring which is attached in close proximity to the fuel lines may ignite the fuel.

Failure to follow these instructions may cause property damage, personal injury or even death.

3. Find a suitable mounting location for the included circuit breaker – it must be mounted on a flat surface, within approximately 6" of the vehicle's battery (the closer the better), at a point where it will not interfere with the operation of any components.

Using the two included self-tapping screws, attach the circuit breaker.

4. Route the red 12 gauge wire to the circuit breaker and cut it. Strip ¼" of insulation from the end of the wire and crimp it onto one of the #10 ring terminals.

Attach the terminal to the silver post on the circuit breaker (identified as 'AUX') with one of the included nuts.

6. Attach one end of the remaining length of red 12 gauge wire to the gold post on the circuit breaker (identified as 'BAT') in the identical manner.

Route this wire to the positive post and cut to length.

If helpful, you may use the included 5/16" ring terminal to attach it. The vehicle's engine must be off when you attach the wire to the post.

7. Ensure that a good ground exists between the frame of the towing vehicle and the frame of the towed vehicle.

Note: to confirm that the charge line is functioning...

- With the motorhome engine running, connect a volt meter or test light from the number 4 pin in the motorhome socket to the motorhome ground.
- If the volt meter or test light indicates 12 VDC+, the charge line is functioning.

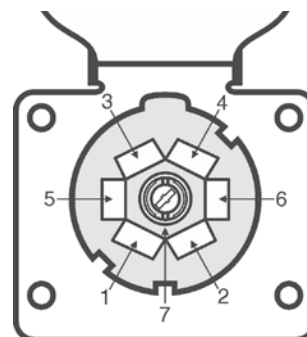

Figure 1

Purpose

Once charge line kits are installed in both the motorhome and towed vehicle, they will help maintain the vehicle's battery charge while in tow, supplying up to 15 amps of current to the battery.

Required tools

- wire crimper
- side cutters
- volt meter or test light

Pin Number	Socket Code	Roadmaster Wire Code	Motorhome/ Towed Vehicle
1.....	White.....	White.....	Ground
2.....	Blue.....	Blue.....	Brake monitor light (electric trailer brakes)
3.....	Green.....	Brown.....	Taillights
4.....	Black.....	Black.....	Charge line
5.....	Red.....	Yellow.....	Left turn/Stop
6.....	Brown.....	Green.....	Right turn/Stop
7.....	Yellow.....	N/A*	Auxiliary/Access

* 'N/A' means this socket is not used in this wiring configuration.