



Solar Controller / Battery Charger

Input: DC12V Solar panel (Max. 25V)

Output: DC12V 10A / DC12V 15A

Model Number: ZS-10A / ZS-15A

User's Manual

FEATURE

- Advanced MCU control pulse width modulated (PWM) technology, high efficiency operation.
- Target for Gel, AGM, Conventional lead-acid (WET) and Calcium Batteries.
- Built in regulator to prevent your battery from being overcharged. Overcharging occurs when the charge voltage is unregulated. This can result in premature battery failure.
- Come with regulator to prevent your battery from being under charged, in the solar energy field, battery undercharge always occurs, especially on some Conventional lead –acid or Calcium batteries; The unit provides an automatic Equalization feature for deeply drained Conventional lead acid battery or Calcium battery, as well as provides a cycling automatic Equalizing feature every 28 days.
- Can be connected to the battery permanently to keep the battery fully charged by using a process called “floating”. This means the controller will stop charging when the battery is full and will automatically start charging the battery as required. This process will also reduce water loss and help prevent the battery from ‘drying out’.
- Protects your battery from discharge at night. Under low light or no light conditions the solar panel voltage could be less than the battery voltage. The unit contains a special circuit which prevents current flowing back from the battery and into the solar panel.
- Colored LED’s to easily indicate the operational status and battery conditions.
- Digital LCD to directly display battery voltage, charging current, charging capacity (Amp hour), battery types, full charge and faulty codes.
- Provides external battery temperature sensor (Optional).
- Multi charging protections against reverse polarity, short circuit, over temperature, over voltage, etc.
- Surface Mount or Flush Panel Mount options.
- Conformal-coating circuit boards and plated terminals apply to hostile environments.
- Waterproof and non-waterproof selectable.

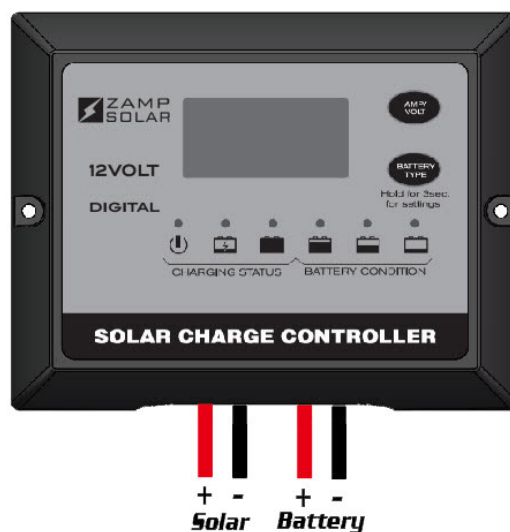

For use with 12Volt Solar Panel Only
Suitable for Solar panels up to 170 / 255 Watts for ZS-10A / ZS-15A

WARNING – IMPORTANT PLEASE READ

- This charger is designed for indoor use (non-waterproof type) or outdoor Use (waterproof type).
- Do not disassemble the controller. Take to a qualified person if the unit requires repairing.
- Lead acid batteries can be dangerous. Ensure no sparks or flames are present when working near batteries.
- Eye protection should always be used. Never short circuit the battery
- Given sufficient light solar panels always generate energy even when they are disconnected.
- Accidental 'shorting' of the terminals or wiring can result in sparks causing personal injury or a fire hazard. We recommend that you cover up the panel(s) with some sort of soft cloth so you can block all incoming light during the installation. This will ensure that no damage is caused to the Solar Panel or Battery if the wires are accidentally short circuited.
- Always install a battery fuse on each circuit including the solar controller
- Do not reverse connect the wires to the solar panel or battery

MOUNTING THE DEVICE

The Solar Controller is mounted as below

The quickest and easiest way to mount the unit is to use the two plastic spacers and self tapping screws supplied and mount the unit to a flat surface,

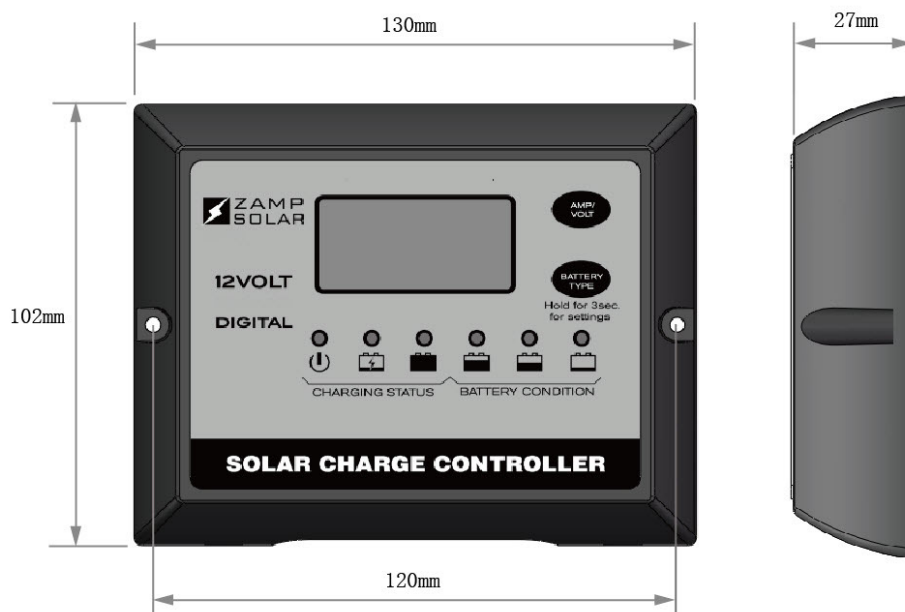

WIRING CONNECTIONS

To protect the Battery and the Solar Panel, we strongly recommend that you place a inline fuse on the positive wire on both the “Solar” and “Battery” Circuits. 20A fuse for ZS-10A, 30A fuse for ZS-15A (As close to the Battery /Panel as possible)

The Solar Controller has 4 terminals which are clearly marked ‘Solar’ and ‘Battery’. There is a (12V) and earth (GND) terminal for each circuit.

Refer to the wiring diagram below.

Correct Wire Size:

Please refer to the wire size chart below to determine the minimum size wire needed for each connection. This will also ensure you get the best performance out of your solar regulator.

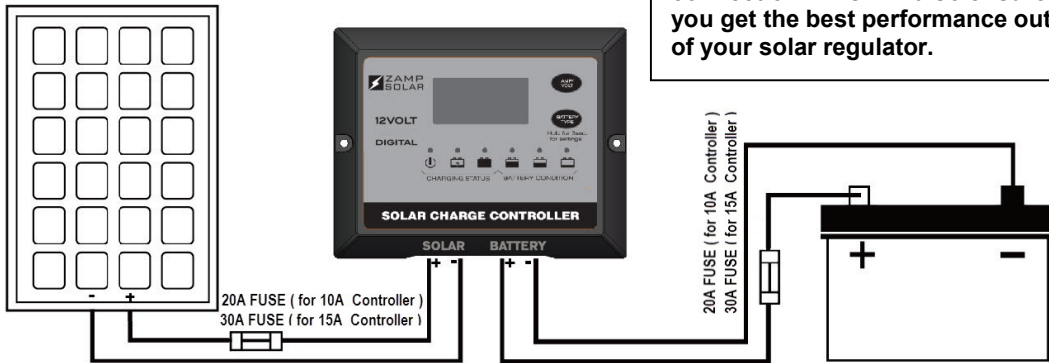

Length of Wire	Battery Connection	Solar Array Connection		
	< 0.9m	6m	9m	12m
Size (AWG)	18 or 16	14	12	12

1. Using the stranded wires, screw tightly the wires to the “Solar” terminal on the back of controller and connect to the Solar Panel like shown.
2. Using the stranded wires, screw tightly the wires to the “Battery” terminal on the back of controller and connect to the Battery like shown.

When the connections are completed, the Solar Controller will start working automatically.

OPERATION - LCD DISPLAY

Please check your battery manufacturer’s specifications to select correct battery type. The unit provides 4 battery types for selections: Gel, AGM, WET (conventional lead acid), and Calcium.

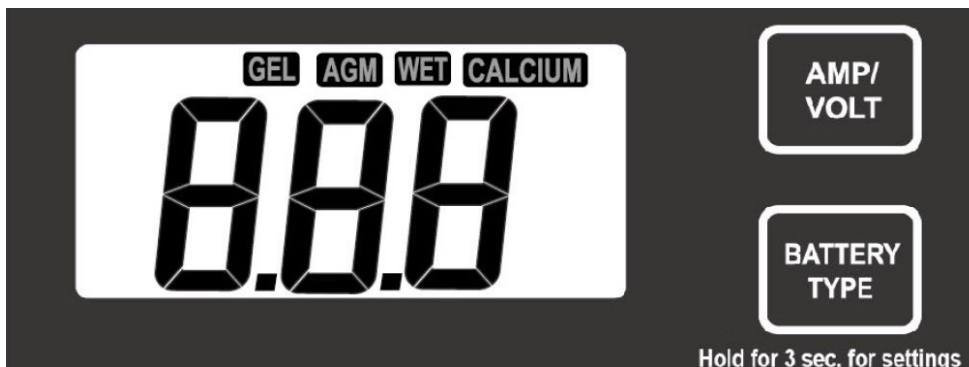

Press **BATTERY TYPE button** and hold for 3 seconds to go into your battery type selection mode, the battery type you select will be shown on the LCD meter, the default setting is AGM Battery; the controller will automatically memorize your battery type setting.

Caution: Incorrect battery type setting may damage your battery.

When the controller powers on, the unit will run self-qualify mode and automatically show below items on LCD before going into charging process

 Self-test starts, digital meter segments test

 Software version test

  Rated voltage and current test



 External battery temperature sensor test (if connected)

After going into charging process, the LCD displays the charging statuses as below:
Press **VOLT / AMP button** in sequence, the LCD will display in turn with Battery Voltage, Charging Current, Charged capacity (Amp-hour) and Battery Temperature (if external temperature sensor connected)

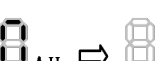
Display in the day time-





 ⇒  ⇒  ⇒ 

Display during the night-

 ⇒ 

Display when battery fully charged

Press **VOLT / AMP button** in sequence, the LCD will display in turn with Battery Voltage, Charging Current, if you do not press the button, the LCD will alternatively display the FUL and VOLT or FUL and AMP every 2 seconds

 ⇒  or  ⇒ 

CHARGING STAGES

The **VOLT / AMP button** can be changed at any time during charging process.

The LCD also can be treated as an independent voltage meter or thermometer. A voltage less than 11.5V Volts indicates that the battery is discharged and needs re-charging.

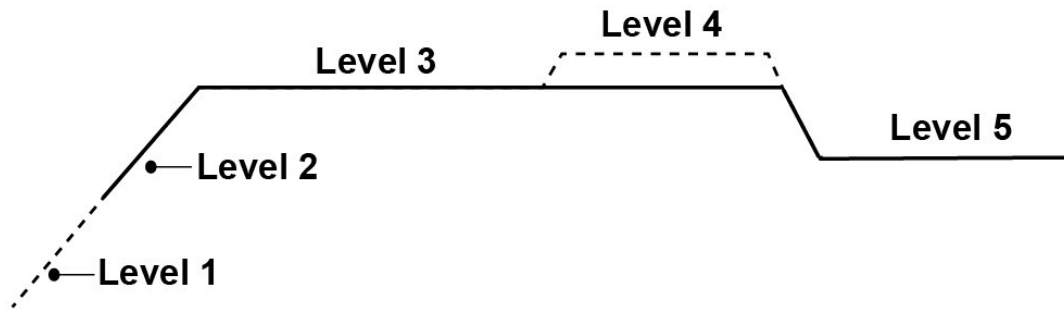

Soft Charge- When batteries suffer an over-discharge, the controller will softly ramps the battery voltage up to 10V.

Bulk Charge-Maximum current charging until batteries rise to Absorption level

Absorption Charge-Constant voltage charging and battery is over 85%.





Equalization Charge*-Only for WET battery or Calcium battery type, when the battery is deeply drained below 10V, it will automatically run this stage to bring the internal cells as an equal states and fully complement the loss of capacity.(Gel and AGM battery do not run Equalization charge)







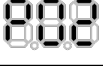



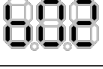

Float Charge-Battery is fully charged and maintained at a safe level.
A fully charged battery has a voltage of more than 13.6 Volts.

OPERATION - L.E.D. INDICATION

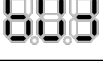
The 6 LED's indicate the charging status and the battery condition						
	Red	Blue	Green	Green	Yellow	Red
Solar Power Present-No battery connected	ON	OFF	OFF	OFF	OFF	Flash
Soft charging	ON	Flash	OFF	OFF	OFF	ON
Bulk charging	ON	ON	OFF	Subject to battery voltage		
Absorption charging	ON	ON	OFF	ON	OFF	OFF
Equalization charging	ON	ON	OFF	ON	OFF	OFF
Float charging	ON	OFF	ON	OFF	OFF	OFF
Solar panel weak	Flash	OFF	OFF	Subject to battery voltage		
At night no charge	OFF	OFF	OFF	Subject to battery voltage		
Battery Voltage below 11.5V (+/-0.2V)	ON	ON	OFF	OFF	OFF	ON
Battery Voltage between 11.5V - 12.5V(+/-0.2V)	ON	ON	OFF	OFF	ON	OFF
Battery Voltage above 12.5V (+/-0.2V)	ON	ON	OFF	ON	OFF	OFF

ABNORMAL OPERATION MODE

Solar panel abnormal mode	LCD display	LED indication	LCD backlight
Solar panel weak		 Flash	ON
Solar panel reverse connection		 Flash	Flash
Solar panel over voltage (> 26.5V)		 Flash	Flash

Battery abnormal mode	LCD display	LED indication	LCD backlight
Battery disconnected or less than 3.0V		 Flash  Flash  Flash	Flash
Battery reverse connection		 Flash	Flash
Battery over voltage than > 17.5V		 Flash	Flash
Battery temperature over 65C		 Flash  Flash  Flash	Flash

The solar controller abnormal mode	LCD display	LED indication	LCD backlight
The controller over temperature protection			Flash

OPTIONAL EXTERNAL DEVICE

The controller provides an optional devices (excludes in the packaging box).

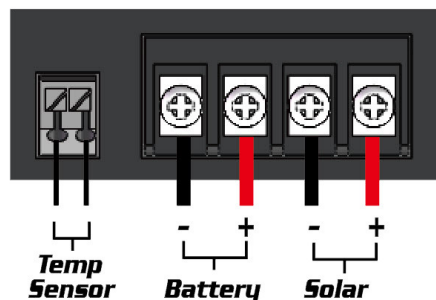

Optional external Battery temperature sensor:

As an option, the unit provides a port to connect the external battery temperature sensor; If the external battery temperature sensor is connected, the unit will optimize the charging performance subjected to the battery temperature detected and also provide the battery over temperature protection, in some case, if battery over temperature occurs, the controller will automatically stop charging.

SPECIFICATIONS

1	Electrical Parameters			
1-1	Rated solar panel amps for ZS-15A	15	Max.	AMP
1-2	Rated solar panel amps for ZS-10A	10	Max.	AMP
1-3	Normal input Solar cell array voltage	15-22		VDC
1-4	Max. solar cell array voltage (output has no load)	25	Max.	VDC
1-5	The controller lowest operating voltage (at solar or battery side)	8V	Min	VDC
1-6	Standby current consumption at night	5	Max	mA
1-7	Maximum voltage drop-Solar panel to battery	0.25	Max.	VDC
2	Charging characteristics			
2-1	Minimum battery start charging voltage	3	Min	VDC
2-2	Soft start charging voltage	3-10	+/-0.2	VDC
2-3	Soft start charging current (50% PWM duty)	Up to 15		AMP
2-4	Bulk charge voltage	10-14.0	+/-0.2	VDC
2-5	Absorption charging voltage at 25°C			
	--Gel type battery	14.1	+/-0.2	VDC
	--AGM type battery (default setting)	14.4	+/-0.2	VDC
	--WET type battery	14.7	+/-0.2	VDC
	--Calcium type battery	14.9	+/-0.2	VDC
2-6	Absorption transits to Equalizing or Float condition:			
	--Charging current drops to	0.5	+/-0.1	AMP
	-- or Absorption charging timer timed out	4		Hour
2-7	Equalization charging active			
	--Only for WET or Calcium battery			
	--Battery voltage discharged to less than	10	+/-0.2	VDC
	--Automatic equalizing charging periodical	28		Day
2-8	Equalization charging voltage at 25°C	15.5	+/-0.2	VDC
2-9	Equalization charging timer timed out	2		Hour
2-10	Float charging voltage at 25°C	13.6	+/-0.2	VDC
2-11	Voltage control accuracy	+/- 1%		
2-12	Battery temperature compensation coefficient	-24		mV/°C
2-13	Temperature compensation range	-20 ~ +50		
				°C
3	Protection			
3-1	Against reverse polarity or short circuit at panel side			
3-2	Against reverse polarity or short circuit at battery side			
3-3	No reverse current from battery to solar at night			
3-4	Over temperature protection during charging	65		°C
3-5	Transient over voltage protection with TVS or varistor			
4	Electrical parts			
4-1	Input output terminal	M4 terminals		
4-2	Temperature sensor port (Press and Release type)	DA 250-350 2P		
5	Physical Parameters			
5-1	Controller material	Plastic, Standard ABS		
5-2	Power terminal maximum stranded wire size	#12 AWG stranded-3 mm ²		
5-3	Mounting	Vertical wall mounting		
5-4	IP grade	IP22 or IP66,		
5-5	Net weight	Approx. 250g		
6	Environmental characteristics			
6-1	Operating temperature	-25 ~ 50°C		
6-2	Storage temperature	-40 ~ 85°C		
6-3	Operating Humidity range	100% no condensation		