

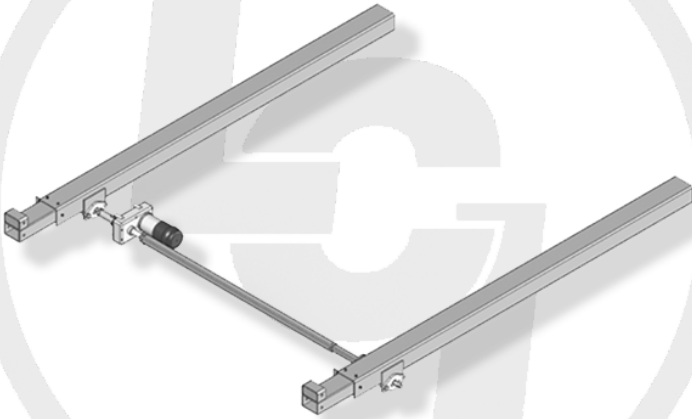

**LIPPERT COMPONENTS**

**2 x 3 SLIDEOUT SYSTEM  
OPERATION AND SERVICE MANUAL**





## TABLE OF CONTENTS

<b>SYSTEM.....</b>	<b>3</b>
<b>Warning.....</b>	<b>3</b>
<b>Description.....</b>	<b>3</b>
<b>Prior to Operation.....</b>	<b>4</b>
<b>OPERATION.....</b>	<b>5</b>
<b>Main Components.....</b>	<b>5</b>
<b>Mechanical.....</b>	<b>5</b>
<b>Electrical.....</b>	<b>6</b>
<b>Operating System.....</b>	<b>7</b>
<b>Extending Slideout .....</b>	<b>7</b>
<b>Retracting Slideout .....</b>	<b>7</b>
<b>Manual Operation.....</b>	<b>8</b>
<b>Preventative Maintenance.....</b>	<b>9</b>
<b>SERVICE.....</b>	<b>10</b>
<b>Troubleshooting.....</b>	<b>10</b>
<b>Slideout Adjustment Chart.....</b>	<b>11</b>
<b>Adjustment Instructions.....</b>	<b>12</b>
<b>Chart.....</b>	<b>13</b>
<b>Motor.....</b>	<b>14</b>
<b>Ordering Parts.....</b>	<b>15</b>

# **SYSTEM**

## **WARNING**

**FAILURE TO ACT IN ACCORDANCE WITH THE FOLLOWING MAY RESULT IN SERIOUS PERSONAL INJURY OR DEATH.**

**The *Lippert 2 x 3 Slideout System* is intended for the sole purpose of extending and retracting the slideout room. Its function should not be used for any other purpose or reason than to actuate the slideout room. To use the system for any reason other than what it is designed for may result in damage to the coach and/or cause serious personal injury or even death.**

**Before actuating the system, please keep these things in mind:**

- 1. Parking locations should be clear of obstructions that may cause damage when the slideout room is actuated.**
- 2. Be sure all persons are clear of the coach prior to the slideout room actuation.**
- 3. Keep hands and other body parts away from slideout mechanisms during actuation. Severe injury or death may result.**
- 4. To optimize slideout actuation, park coach on solid and level ground.**

## **DESCRIPTION**

The *Lippert 2 x 3 Slideout System* is a rack and pinion style slide system. Utilizing a bi-directional electric motor to actuate the drive shaft, the slideout room is extended and retracted from the same source. The actuator has a built-in automatic clutching feature. The *Lippert 2 x 3 Slideout System* is designed as a negative or positive ground system.

The *Lippert 2 x 3 Slideout System* is mounted into the frame and allows the floor of the slideout room, in the fully extended position, to be flush with the floor of the unit, in some circumstances.

There are no serviceable parts within the electric motor. If the motor fails, it must be replaced.

Disassembly of the motor voids the warranty.

Mechanical portions of the slideout system are replaceable. Contact Lippert Components, Inc. to obtain replacement parts.

## **WELD-ON 2 x 3 – see Fig. 1 page 5**

The *Lippert 2 x 3 Slideout System* has three basic assemblies:

1. **Outer Rail** – Angled flange is welded to frame of coach. Flange runs from approximately halfway forward of the inside end of the outer rail to outer edge of Gear Drive Assembly.
2. **Inner Rail** - Inner Rail rides inside outer rail and is actuated by the rack gear welded to the bottom of the rail and the pinion gear in the Gear Drive Assembly. Mounting Plate on the outside end of the inner rail is bolted to the slideout room and is slotted for room adjustment.
3. **Gear Drive** – Houses drive shaft and pinion gear. 12V DC motor attaches to drive shaft to actuate system.

## **PRIOR TO OPERATION**

Prior to operating the *Lippert 2 x 3 Slideout System*, follow these four (4) guidelines:

1. Unit should be parked on the most level surface available.

The following are for Class A and C Units (Gas and Diesel):

2. The **PARKING BRAKE** must be engaged.
3. The unit's transmission must be in **NEUTRAL** or **PARK**.
4. The unit's ignition must be in the **RUN** position or the unit's engine must be running.

# MAIN COMPONENTS

## MECHANICAL

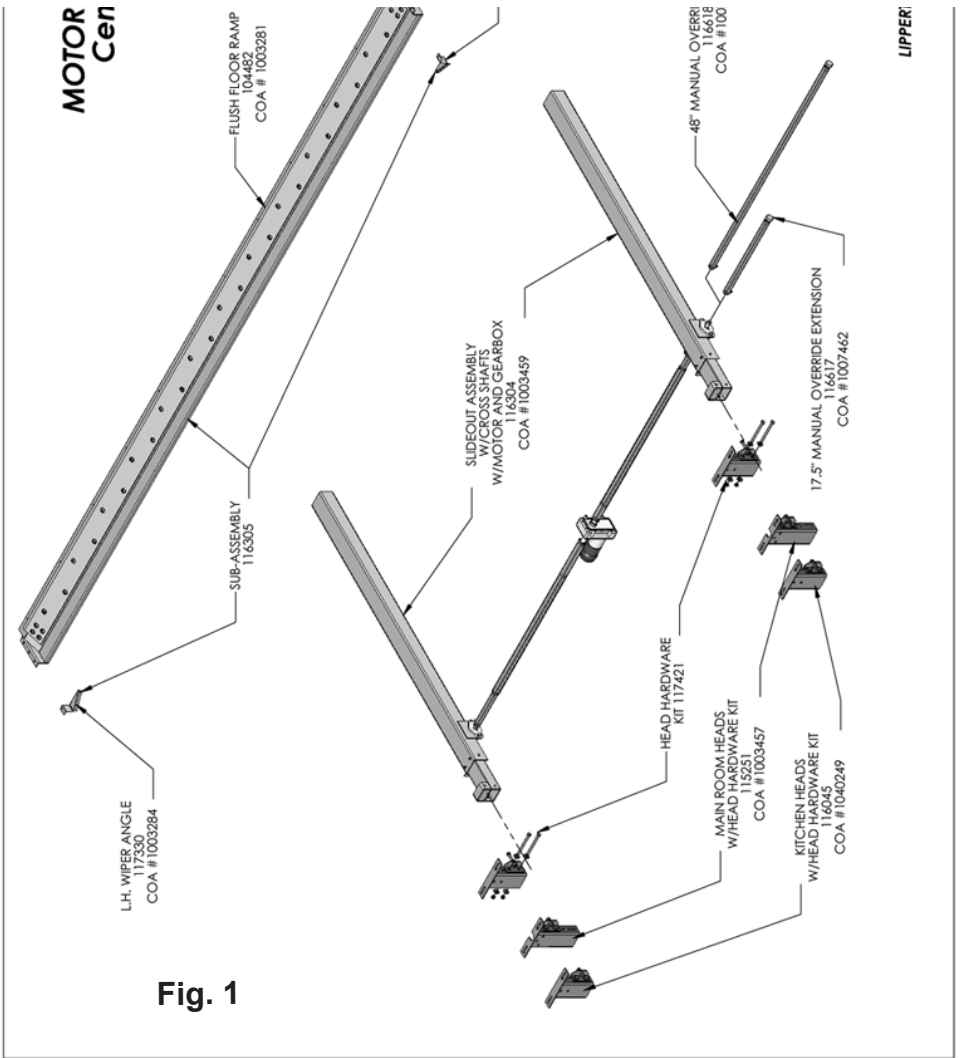

# ELECTRICAL

## Motor - 12V DC

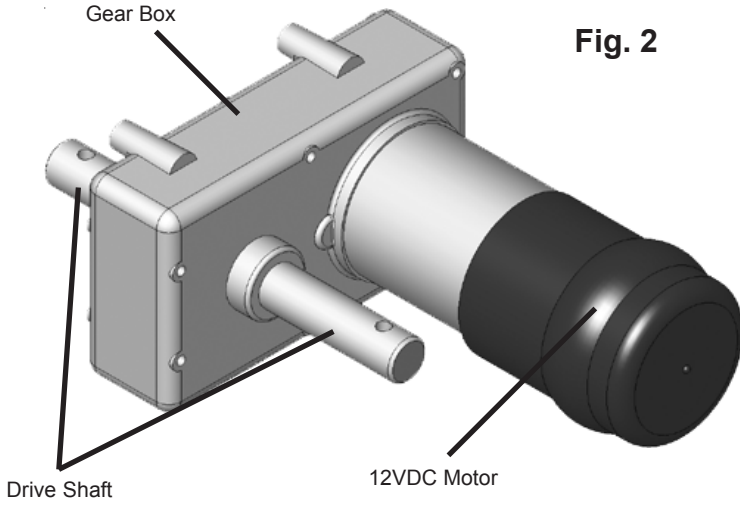

**Fig. 2**

## Wall Switch

**Fig. 3**

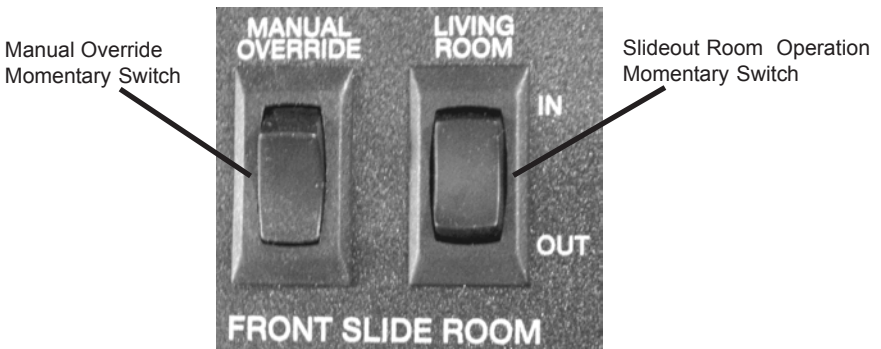

## Circuit Breaker – Supplied by OEM

## WARNING

ALWAYS MAKE SURE THAT THE SLIDEOUT ROOM PATH IS CLEAR OF PEOPLE AND OBJECTS BEFORE AND DURING OPERATION OF THE SLIDEOUT ROOM.

ALWAYS KEEP AWAY FROM THE SLIDE RAILS WHEN THE ROOM IS BEING OPERATED. THE GEAR ASSEMBLY MAY PINCH OR CATCH ON LOOSE CLOTHING CAUSING PERSONAL INJURY.

INSTALL TRANSIT BARS (IF SO EQUIPPED) ON THE SLIDEOUT ROOM DURING STORAGE AND TRANSPORTATION.

## EXTENDING SLIDEOUT ROOM

1. Level Unit
2. Verify the battery is fully charged and hooked up to the electrical system.
3. Remove transit bars (if so equipped).
4. Press and hold the IN/OUT switch (Fig. 4B ) in the OUT position until room is fully extended and stops moving.
5. Release switch, which will lock the room into position.

**NOTE:** Only hold OUT switch until room stops.

## RETRACTING SLIDE-OUT ROOM

1. Verify the battery is fully charged and hooked up to the electrical system.
2. Press and hold the IN/OUT switch (Fig. 4A ) in the IN position until the room is fully retracted and stops moving.
3. Release the switch. This will lock the room into position.

**NOTE:** Only hold IN switch until room stops.

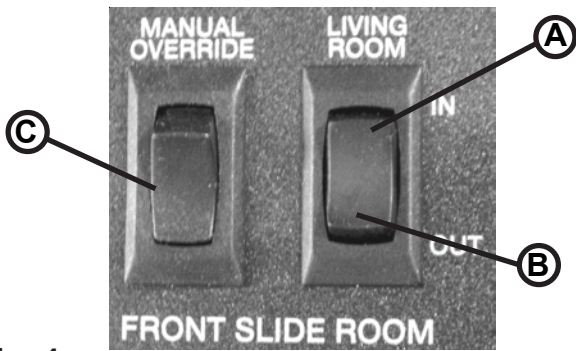
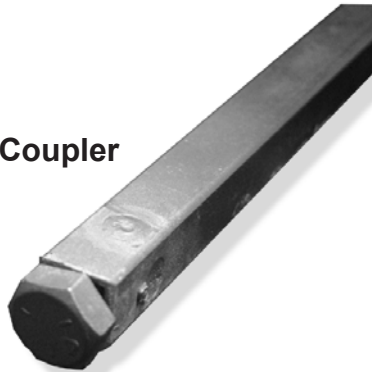

Fig. 4

## MANUAL OPERATION

Fig. 5-Manual Override Coupler



### WARNING!

**Always disconnect battery from system prior to manually operating system. Failure to disconnect battery can cause electricity to backfeed through the motor and cause serious damage to the system as well as void the warranty.**

1. Prior to Manual Operation, be sure slideout area is clear of any obstructions that may impede the extension or retraction of the slideout room, including transit bars.
2. Locate slideout mechanism under unit.
3. System is made up of left and right slideout arms or rails. In front wheel well, locate the Manual Override Coupler (Fig. 5).
4. Fit a 15/16" socket and ratchet, open or closed end wrench or nut driver and power drill over the Manual Operation Coupler.
5. A second person is required to be on the inside of the unit to push the MANUAL OVERRIDE SWITCH (Fig. 3) The switch must be pushed up into the on position and held during the entire process of manually moving the room.
6. When the slideout room has been retracted or extended to the desired location, the MANUAL OVERRIDE SWITCH can be released. By releasing the switch, the motor brake is reset to keep the slideout room in place.

**NOTE:** Remember to replace transit bars prior to moving the unit.



## **WARNING!**

The gears can be stripped out if the room is manually retracted/extended to its fullest extent and the operator continues to rotate manual override.

Any damage due to misuse of the Manual Override feature will disqualify any and all claims to the Limited Warranty.

## **PREVENTATIVE MAINTENANCE**

The *Lippert 2 x 3 Slideout System* has been designed to require very little maintenance. To ensure the long life of your slideout system, read and follow these few simple procedures.

### **WARNING**

**DO NOT WORK ON YOUR SLIDEOUT SYSTEM UNLESS THE BATTERY IS DISCONNECTED. FAILURE TO ACT IN ACCORDANCE WITH THE FOLLOWING MAY RESULT IN SERIOUS PERSONAL INJURY OR DEATH.**

- When the room is out, visually inspect the Inner and Outer Rail Assemblies. Refer to Fig. 1 for location of inner rail assemblies. Check for excess build-up of dirt or other foreign material; remove any debris that may be present.
- If the system squeaks or makes any noises it is permissible to apply a coat of lightweight oil to the drive shaft and roller areas but remove any excess oil so dirt and debris do not build-up. **DO NOT** use grease.

**IF YOU HAVE ANY PROBLEMS OR QUESTIONS CONSULT YOUR LOCAL AUTHORIZED DEALER OR CALL LIPPERT AT:  
(866) 524-7821.**

# **SERVICE**

## **TROUBLESHOOTING**

The *Lippert 2 x 3 Slideout System* is only one of four inter-related slideout room system components. These four components are as follows: chassis, slideout room, coach and *Lippert 2 x 3 Slideout System*. Each one needs to function correctly with the others or misalignment problems will occur.

Every coach has it's own personality and what may work to fix one coach may not work on another even if the symptoms appear to be the same.

When something restricts room travel, system performances will be unpredictable. It is very important that slide rails, inner and outer, be free of contamination and allowed to travel freely the full distance. Ice or mud build-up during travel is an example of some types of contamination that may occur.

When beginning to troubleshoot the system, make sure the battery is fully charged, there are no visible signs of external damage to the actuator, motor or rails and that the motor is wired properly and all connections are secure.

You can adjust room extension by modifying the position of the rack gear on the inner rail to the spur gear on the gear assembly.

**IF YOU HAVE ANY PROBLEMS OR QUESTIONS CONSULT YOUR LOCAL  
AUTHORIZED DEALER OR CALL LIPPERT AT:  
(866) 524-7821.**

# ROOM ADJUSTMENT DIAGRAM

**Fig. 6b - Alignment Plate**

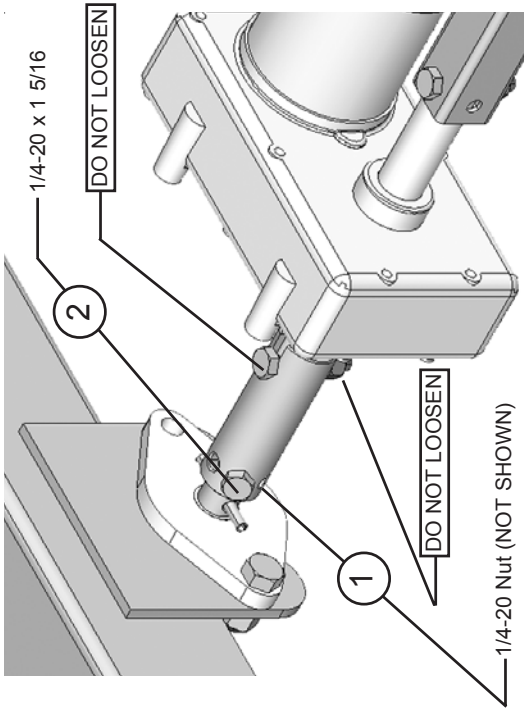
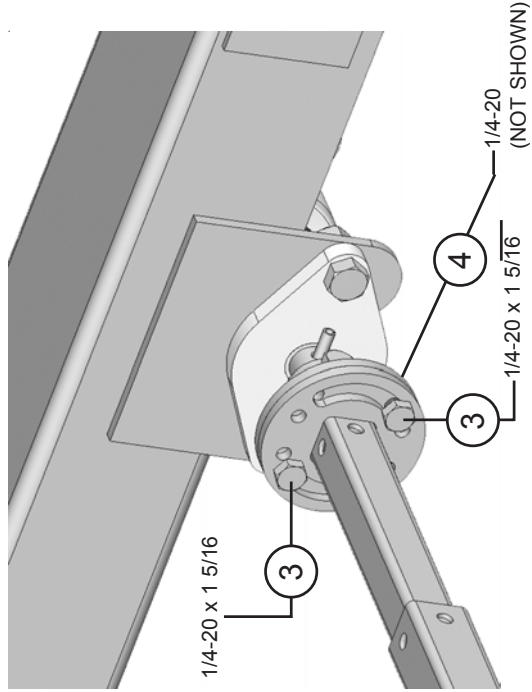

**Fig. 6a - Timing Adapter**

## **INSTRUCTIONS FOR ADJUSTMENT OF ROOM.**

The *Lippert 2 x 3 Slideout System* can be timed and fine-tuned for optimum performance. In the event the travel of either side of this two-rail system should be out of time, follow this process for re-timing the slide-out room.

**Note:** When addressing issues regarding your slide-out room, remember to relay the information from the OUTSIDE of the coach. This note will help to standardize the information needed to be relayed to a service station or technical service at **LCI**.

### **Timing Adapter- (Fig. 6a)**

1. Turn off engine. (Class A and C motorhomes; Gas or Diesel)
2. Disconnect battery or slide-out motor wire leads. (Only one of the motor leads need be disconnected.)
3. Remove nut (Fig. 6a, #1) from bolt (Fig. 6a, #2).
4. Remove bolt from Timing Adapter. This frees the Timing Adapter from the gear assembly drive shaft.
5. Rotate drive shaft towards outside of coach until the next set of holes on the Timing Adapter line-up.
6. Return bolt to Timing Adapter assembly in new location.
7. Return nut to bolt and snug firmly.
8. Reconnect motor wire or battery
9. Draw room into coach.
10. Repeat process as needed.

### **Alignment Plate – (Fig. 6b)**

1. Turn off engine. (Class A and C motorhomes; Gas or Diesel)
2. Disconnect battery or slide-out motor wire leads. (Only one of the motor leads need be disconnected.)
3. Loosen both nuts (Fig. 6b, #4, not shown) from both bolts (Fig. 6, #3) on Alignment Plate.
4. This allows for a free rotation of Alignment plate.
5. Rotate drive shaft towards inside of coach until room is in alignment from right to left.
6. Tighten nuts on bolts on Alignment Plate assembly in new location.
7. Reconnect motor wire or battery
8. Draw room into coach.
9. Repeat process as needed.

During troubleshooting, remember, by changing, altering or adjusting one thing, it may affect something else. Be sure any changes do not create a new problem.

# TROUBLESHOOTING CHART

The following troubleshooting chart outlines some common problems, their causes and possible corrective actions. When reference is made to a "Power Unit," the term includes the motor and the actuator as a complete unit. All Power Units are shipped from the factory with a serial number and date code, which should be given to the service technician when asking for assistance.

## ROOM DOESN'T MOVE WHEN SWITCH IS PRESSED

### PROBABLE CAUSE

Restriction or obstruction inside or outside of unit

Low battery voltage, blown fuse, defective wiring

Excessive room drag

### CORRECTIVE ACTION

Check for and clear obstruction

Check battery voltage and charge if needed  
Find and check fuse, replace if blown. Check battery terminals and wiring. Look for loose disconnected or corroded connectors.

Check that transit bars are removed

## POWER UNIT RUNS, ROOM DOES NOT MOVE

Motor turns, room does not move

Broken gear on drive shaft

Broken gear in gearbox

Bad motor or gearbox

Gear key is broken or lost, replace gear drive assembly

Replace gear drive assembly

Replace motor/gearbox assembly

Replace motor/gearbox assembly

## POWER UNIT RUNS, ROOM MOVES SLOWLY

Low battery, poor ground, extremely low temperature

Room in bind

Incorrect height adjustment

Charge battery, check ground wire

Adjust to proper room setting

Check for proper room height

## ROOM STARTS TO MOVE AND STOPS

Low battery voltage, blown fuse, defective wiring

Obstruction of room inside or outside

Dirts or corrosion build up on mechanism

Check battery voltage and charge if needed

Find and check fuse, replace if blown. Check battery terminals and wiring. Look for loose disconnected or corroded connectors.

Check for and remove any obstruction

Clean dirt or corrosion and coat LIGHTLY with oil

## ROOM CHATTERS DURING OPERATION

Teeth on gear drive broken or worn

Teeth on inner rail broken or worn

Replace gear drive assembly

Replace inner rail assembly

### Notes:

If the slideout room will not retract there is a manual override that is located on the opposite the motor on the gearbox. Once you have the room in the closed position take you unit to the closest dealer. See pages 9-11 for Manual Override Instructions.

### Switch related problems:

- If room moves opposite from what the switch plate indicates, reverse the motor wires on the back of the switch. Wire size must be 10ga. min.
- If a gear is stripped, the entire gearbox must be replaced.

### Switch related problems:

- If room moves opposite from what the switch plate indicates, reverse the motor wires on the back of the switch (refer to the wiring diagram page 15). Wire size must be 10ga. Min.

### WARNING! – HIGH VOLTAGE

- If a gear is stripped, the entire gearbox must be replaced.
- If the room does not seal fully, refer to page 13.

## TROUBLESHOOTING – MOTOR

Before attempting to troubleshoot the Motor, make sure an adequate power source is available. The unit batteries should be fully charged or the unit should be plugged into to A/C service with batteries installed. Do not attempt to troubleshoot the Motor without assuring a full 12V DC charge

The following tests require only a DC voltmeter (or DC test light) and a jumper lead.

**Step 1** - Attach voltmeter (or test light) leads to the negative and positive switch terminals on back of wall switch (See Fig. 7). Does the meter indicate 12V DC? If **YES**, see **Step 2**; if **NO** see **Step 3**.

**Step 2** - If **YES**, at the motor, check the incoming leads to 12V DC (if necessary, disconnect leads at wire splices). Does meter indicate 12V DC? If **YES**, Motor needs to be replaced. The motor is not field serviceable. **DO NOT ATTEMPT TO REPAIR**. If **NO**, Inspect all wires and connections between the wall switch and the motor. Repair connections as necessary. Recheck as in **Step 1**.

**Step 3** - If **NO**, Inspect all connections between battery and switch. Inspect 30A Auto-reset Circuit Breaker (See Fig. 7 for location). Recheck as above in **Step 1**.

Since there are no field serviceable parts in the motor of the Motor, electrical troubleshooting and service is limited to replacing only those components as previously outlined.

Thorough inspection of wiring and connections is the only other electrical service that can be performed.

## ORDERING PARTS

To assist the customer service when ordering parts, please provide the following information:

1. Your Name
2. Company Name
3. Phone Number
4. Shipping Address
5. Billing Address
6. Purchase Order Number
7. Coach
  - A. Serial # and/or VIN #
  - B. Make
  - C. Model
8. Part Number
9. Description
10. Quantity

**Please take your coach to an authorized service center for repairs. Systems that have been modified, adjusted, repaired or augmented by a party other than an authorized service center may void any warranty claim with Lippert Components, Inc.**