



MOUNTING BRACKET KIT INSTALLATION INSTRUCTIONS

KIT# 4408-1

11/4/13
KS

ROADMASTER, Inc. 6110 NE 127th Ave. Vancouver, WA 98682 360-896-0407 fax 360-735-9300 www.roadmasterinc.com

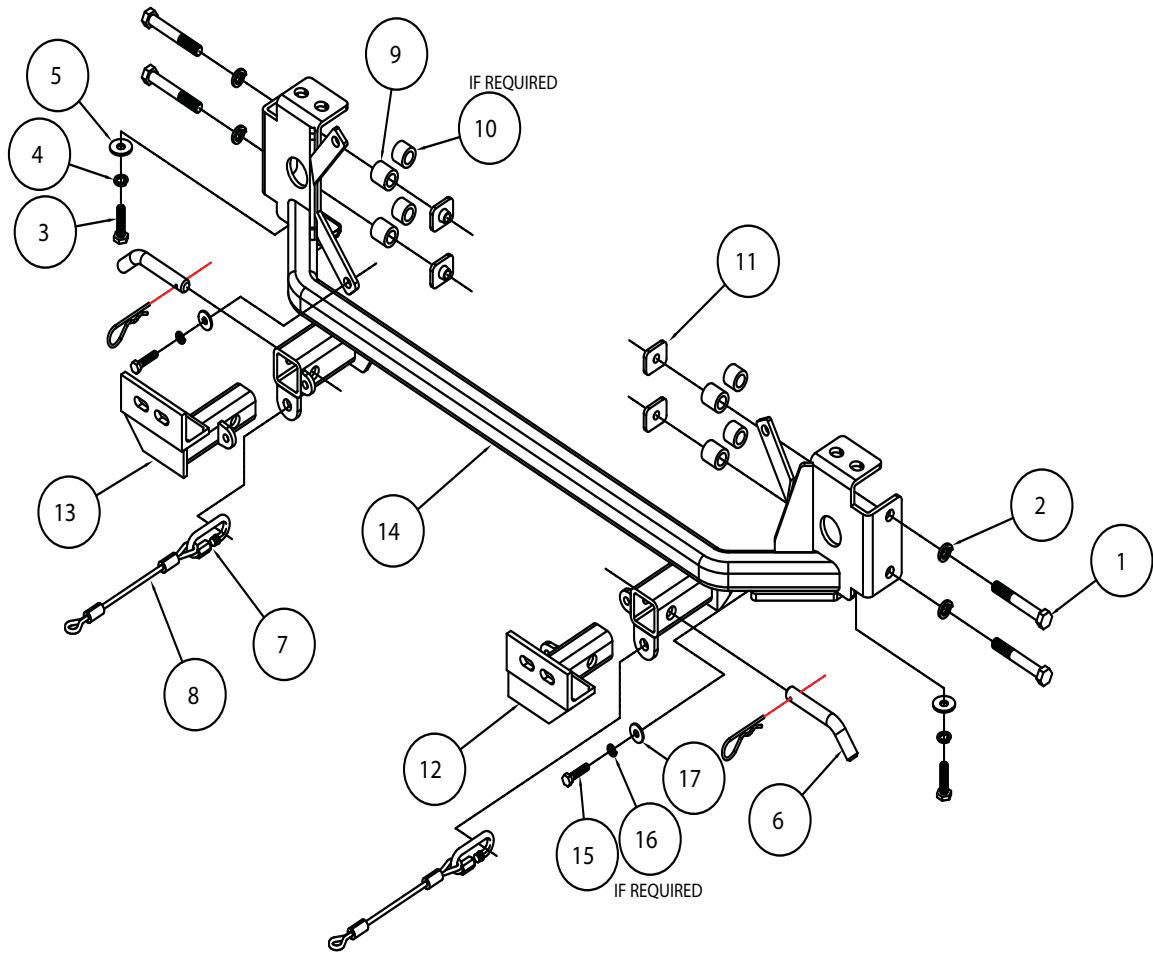

ITEM	QTY	NAME	MATERIAL
1	4	1/2" x 2 1/2" BOLT	350099-00
2	4	1/2" LOCK WASHER	350309-00
3	2	10mm x 1.5 x 40mm BOLT	356103-00
4	2	10mm LOCK WASHER	355715-00
5	2	3/8" FLAT WASHER	350304-00
6	2	5/8" DRAW PIN W/ CLIP	357035-00
7	2	QUICK LINK	200008-00
8	2	SAFETY CABLE	650646-08
9	4	1" O.D. x 0.188 WALL x 1" ROUND TUBE	A-000028
10	4	1" O.D. x 0.188 WALL TUBE x 3/4"	A-000112
11	4	3/16" PLATE x 1 1/4" x 1 1/2"	A-003075
12	1	DRIVER SIDE ARM	C-001508
13	1	PASSENGER SIDE ARM	C-001509
14	1	MAIN RECEIVER	C-001510
15	2	6mm x 1.0 x 35mm BOLT	355896-00
16	2	1/4" LOCK WASHER	350301-00
17	2	1/4" FLAT WASHER	350300-00



MOUNTING BRACKET KIT INSTALLATION INSTRUCTIONS

KIT# 4408-1

11/4/13
KS

ROADMASTER, Inc. 6110 NE 127th Ave. Vancouver, WA 98682 360-896-0407 fax 360-735-9300 www.roadmasterinc.com

This is one of our XL series brackets, which allows the visible front portion of the bracket to be easily removed from the front of the vehicle (Fig.A and Fig.B). The bracket kit consists of a main receiver brace, two removable front braces and a hardware pack. The main receiver brace mounts to the frame rail; the removable front braces install in the main receiver brace.

Before starting the installation, lay out the kit components in order, as they will be used. This will give you a visual idea of how the components work, and will also confirm that everything is present and accounted for.



Fig.A



Fig.B

IMPORTANT: All brackets **must** be assembled with all the bolts left loose for final adjustment and positioning (before tightening) unless otherwise instructed. All bolts **must** be torqued for proper strength. If more than one bolt is used per fastening point, the diagram may only show one.

- Use flat washers over all slotted holes
- Use lock washers on all fasteners

ROADMASTER Limited Warranty, including One-Year Conditional Warranty Text and Product Registration Card, in Carton.

WARNING

Failure to follow these instructions can result in property damage, personal injury or even death.

- Installation of most mounting brackets requires moderate mechanical aptitude and skills. We strongly recommend professional installation by an experienced installer.
- The installer must read the instructions and use all bolts and parts supplied. Failure to do so could result in loss of the towed vehicle.
- Use Loctite® Red on all bolts used for mounting this bracket.
- Every 3,000 miles, the owner must inspect the fasteners for proper torque, according to the bolt torque requirements chart on the last page of these instructions. The owner must also inspect all mounts and brackets for cracks or other signs of fatigue every 3,000 miles. Failure to do so could result in loss of the towed vehicle.
- The owner must check the vehicle manufacturer's instructions for the proper procedure(s) to prepare the vehicle for towing. Some vehicles must be equipped with a transmission lube pump, an axle disconnect, driveline disconnect or free-wheeling hubs before they can be towed. Failure to properly equip the vehicle will cause severe damage to the transmission.
- If running changes were made by the vehicle manufacturer after this bracket was designed, some bolts or other fasteners in the hardware pack may no longer be the correct size. It is the installer's responsibility to verify that the bracket is securely fastened to the vehicle and fitted with the correct hardware to account for these changes. Failure to securely fasten the bracket could result in loss of the towed vehicle.
- If the towed vehicle has been in an accident, it must be properly repaired before attaching the bracket. Do not install the bracket if any structural frame damage is found. Failure to repair the damage could result in the loss of the towed vehicle.
- Roadmaster manufactures many styles of brackets. If your bracket has removable arms, they must be removed before driving the vehicle, unless the arms can be pinned or padlocked in place. If not secured, the arms could vibrate out, resulting in non-warranty damage or personal injury.
- Some motorhome chassis have such a tight turning radius that you can damage your motorhome, towed vehicle, tow bar or bracket while turning sharply. Before getting on the road, test your turning radius in an empty parking lot. Turning too sharply could result in non-warranty damage to towing system, motorhome and/or towed vehicle.
- Do not back up with the towed vehicle attached or non-warranty damage will occur to your towing system, motorhome and/or towed vehicle.
- The safety cables must connect the towing vehicle to the towed vehicle frame to frame, with the cables crossed, with enough slack for sharp turns. Refer to the cable instructions for proper routing. Failure to leave enough slack in the safety cables, or failure to connect the safety cables frame to frame, will result in the loss of the towed vehicle.
- This bracket is designed for use with ROADMASTER tow bars and ROADMASTER adaptors only. Using this bracket with other brands, without an approved ROADMASTER adaptor, may result in non-warranty damage or injury.
- Do not use this document for custom fabrication, as it may not show all parts or structural components. Custom fabrication or an attempt to copy this bracket design could result in loss of the towed vehicle.
- Upon final installation, the installer must inspect the bracket to ensure adequate clearance, particularly around hoses, air conditioner lines, radiators, etc., or non-warranty damage to the towed vehicle will result.
- This bracket is only warranted for the original installation. Installing a used bracket on another vehicle is not recommended and will void the warranty.



MOUNTING BRACKET KIT INSTALLATION INSTRUCTIONS

KIT# 4408-1

11/4/13
KS

ROADMASTER, Inc. 6110 NE 127th Ave. Vancouver, WA 98682 360-896-0407 fax 360-735-9300 www.roadmasterinc.com

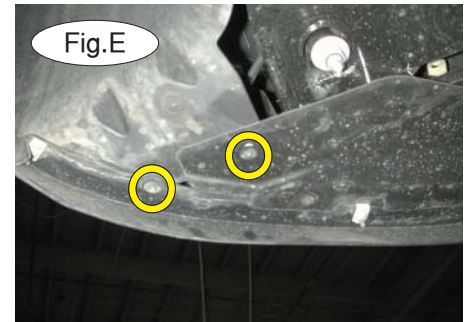
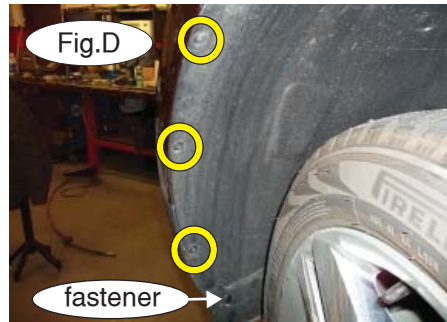
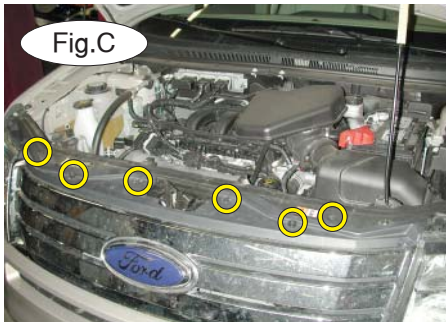

1. **Important:** please use all supplied bolts and parts and read all instructions carefully before beginning this installation. The majority of questions you may have can be answered within the text, and proper installation will ensure safe and secure travel. Now, begin the installation by removing two 10mm bolts and four plastic fasteners attaching the top of the fascia to the core support (Fig.C). *Note:* due to manufacturing variances, there may be six plastic fasteners to remove.

2. Next, on each side, remove three 5.5mm (head) screws attaching the fender liner to the outer edge of the fascia (Fig.D). *Note:* due to manufacturing variances, you may also need to remove a plastic fastener attaching the fender liner to the fascia on each side.

3. On each side, remove two more 5.5mm (head) screws attaching the fender liner and center splash shield to the bottom of the fascia (Fig.E).

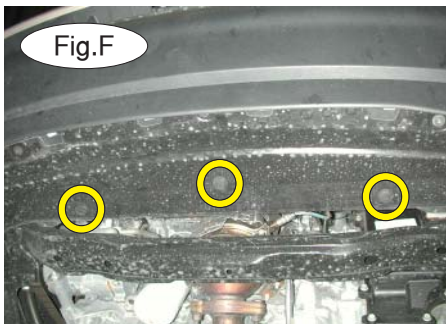

4. Remove three plastic fasteners attaching the center splash shield to the radiator support (Fig.F).

5. Pull back the fender liner and disconnect the fog lights, if the vehicle is so equipped.

6. Now, remove the fascia by pulling out and forward on both of the corners (Fig.G).

7. Support the radiator support (Fig.H). *Note:* you must support the radiator support before removing the bumper core. If you fail to do this, the upper half of the core support could be damaged.

8. **For 2.0 EcoBoost models:** skip to the supplement at the end of these instructions now before returning to step 12 in these instructions. **For all other models:** on each side, remove two 10mm (head) bolts attaching the bumper core to the core support (Fig.I).

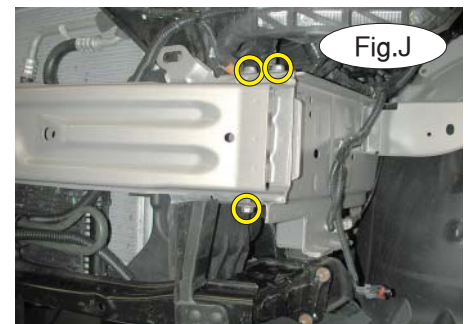
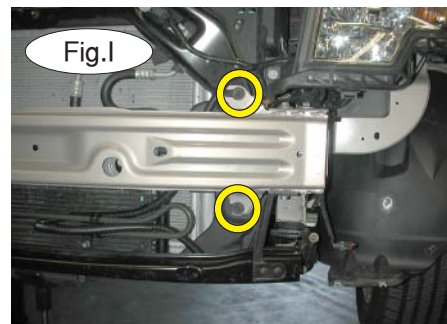

9. On each side, remove three 13mm (head) bolts attaching the bumper core to the frame rails (Fig.J).

Next, remove the bumper core. *Note:* the bumper core will not be re-installed.

Note: retain the bumper core and attachment hardware so that it can be replaced if the bracket is ever removed.



MOUNTING BRACKET KIT INSTALLATION INSTRUCTIONS

KIT# 4408-1

11/4/13
KS

ROADMASTER, Inc. 6110 NE 127th Ave. Vancouver, WA 98682 360-896-0407 fax 360-735-9300 www.roadmasterinc.com

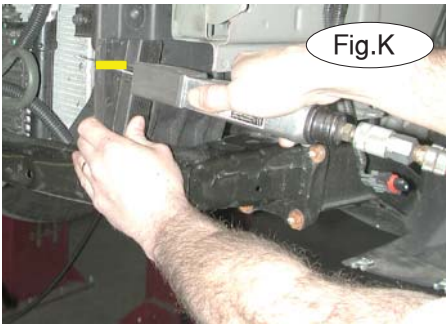

Fig.K



Fig.L



Fig.M

10. Trim the small air deflectors on each side of the lower bumper core. Trim approximately 1" off from the top of each one (Fig.K). Use the yellow marker line in Figure K as a reference. Also, trim the flange on the passenger side using the yellow marker line as a reference (Fig.L).

11. Now, place the main receiver brace over the ends of the frame rails (Fig.M)

12. Bolt the main receiver brace into place using the two upper bumper core mounting bolts you removed in step 9 (Fig.N). *Note:* use thread lock on the factory bolts prior to reinstalling them. On each side, using one of the supplied 10mm x 1.5 x 40mm bolts, fender washers and lock washers, bolt through the lower bumper core mounting point.



Fig.N

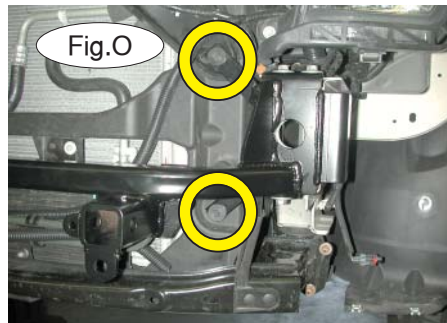

Fig.O

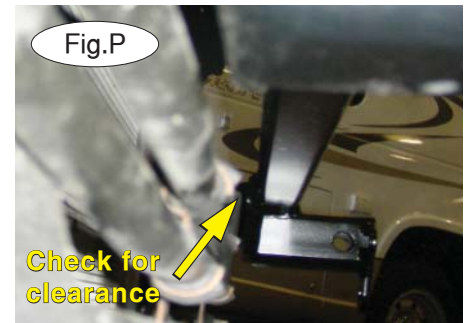

Fig.P

13. On each side, reattach the core support to the main receiver brace using two of the 10mm (head) bolts you removed in step 8 (Fig.O). *Note:* 2.0 EcoBoost models will only have to install one bolt. Use thread lock on the factory bolts prior to reinstalling them. Make certain that the power steering cooler lines are not contacting the main receiver brace. If they are, bend them back (Fig.P).

14. Tighten all main receiver bolts to the torque specifications listed at the end of these instructions.

15. Using the main receiver brace as a template, enlarge both of the existing holes in the side of the frame rail to 1/2" (Fig.Q). Repeat for the other side.

16. On each side, place the two 1" x 1" pipe spacers between the main receiver brace and the side of the frame rail. Make sure to align them with the existing holes in the main receiver brace and the frame rail. Bolt into place using two 2 1/2" bolts and lock washers; finish by placing two 1 1/4" x 1 3/4" backing plates inside the frame through the round opening and onto the bolts (Fig.R). *Note:* you may need to hold the backing plates in place when tightening the bolts in the side of the frame rail (Fig.S). *Note:* due to manufacturing variances, the pipe spacers may need to be ground down slightly. Due to frame variances, the space between the outside point and the frame may vary from side to side. If this is the case, use the provided 3/4" spacers.



Fig.Q

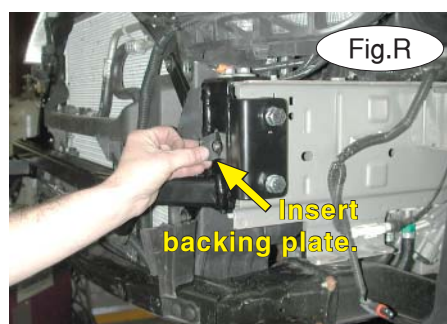

Fig.R

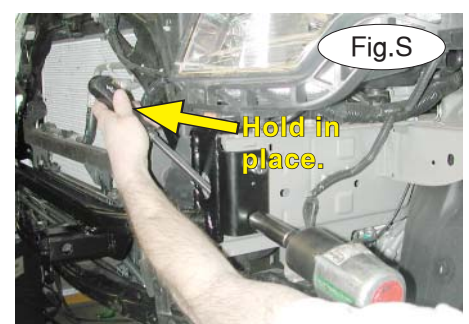

Fig.S



MOUNTING BRACKET KIT INSTALLATION INSTRUCTIONS

KIT# 4408-1

11/4/13
KS

ROADMASTER, Inc. 6110 NE 127th Ave. Vancouver, WA 98682 360-896-0407 fax 360-735-9300 www.roadmasterinc.com

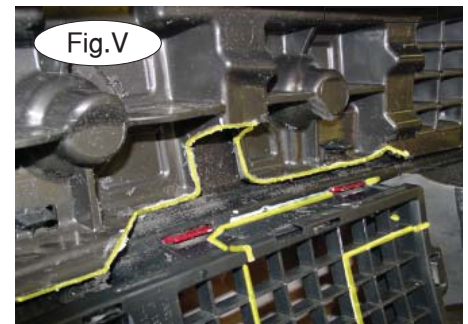
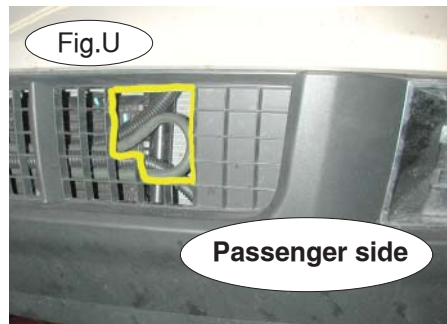
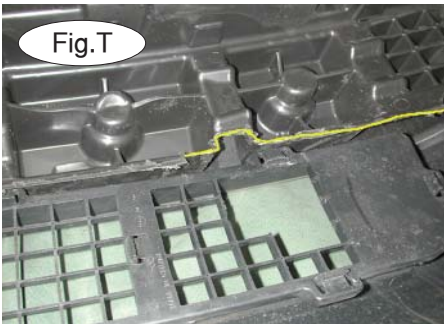

17. Tighten all bolts to the torque specifications listed at the end of these instructions.
18. To allow clearance for the radius of the cross bar and the main receiver brace, the fascia will need to be trimmed. **For '07 to '10 Ford Edge models**, refer to Figures T and U; for **'11 to '13 Ford Edge models**, refer to the supplemental trimming instructions found at the end of these instructions. For **'07 to '10 Lincoln MKX models**, refer to Figures V and W for correct trimming of the fascia and Figure X as a reference for trimming the center portion flush with the grille insert. For **'11 to '13 Lincoln MKX models**, refer to Figures Y and Z for trimming. **For all models**, complete trimming on both sides of the fascia.

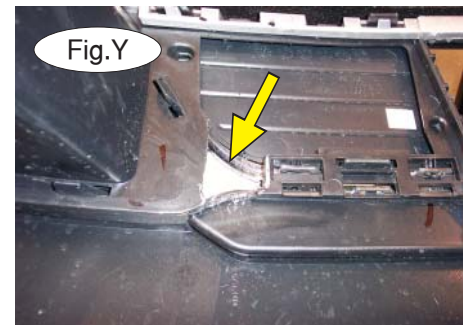
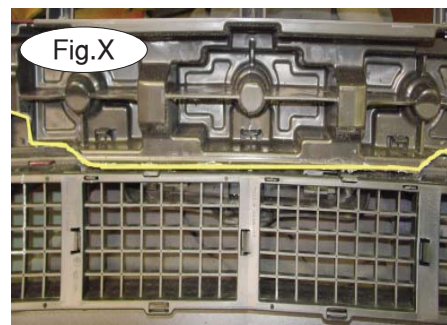

19. Now, reinstall the fascia reversing steps 1 through 6.
20. Fit the removable front braces into the front receiver brace, and secure them in place with the supplied 5/8" draw pins and spring pins.
21. Attach the 8" safety cables with the cable connectors (Q-Links) to the receiver braces (Fig.AA) and attach the ends of the safety cables to the tow vehicle's safety cables and tow bar.
22. Install the tow bar to the mounting bracket according to the manufacturer's instructions.

Note: if the bracket is so equipped, the holes in the alignment tabs which are welded to the arms and main receiver braces are for padlocks only. Under no circumstances should you bolt the alignment tabs together. Bolting the alignment tabs together may result in non-warranty damage to the bracket.

BOLT TORQUE REQUIREMENTS

Note: The torque values represented below are intended as general guidelines. Torque requirements for specific applications may vary. Roadmaster does not warrant this information to be accurate for all applications and disclaims all liability for any claims or damages which may result from its use.

STANDARD BOLTS

Thread Size	Grade	Torque
5/16	5	13 ft./lb.
3/8	5	23 ft./lb.
7/16	5	37 ft./lb.
1/2	5	56 ft./lb.
5/8	5	150 ft./lb.

METRIC BOLTS

Thread Size	Grade	Plated / Unplated
8mm-1.0	8.8	20 ft./lb. 18 ft./lb.
8mm-1.25	8.8	19 ft./lb. 18 ft./lb.
10mm-1.25	8.8	38 ft./lb. 36 ft./lb.
10mm-1.5	8.8	37 ft./lb. 35 ft./lb.

METRIC BOLTS

Thread Size	Grade	Plated / Unplated
12mm-1.25	8.8	70 ft./lb. 65 ft./lb.
12mm-1.5	8.8	66 ft./lb. 61 ft./lb.
12mm-1.75	8.8	65 ft./lb. 60 ft./lb.
14mm-2.0	8.8	104 ft./lb. 97 ft./lb.



MOUNTING BRACKET KIT INSTALLATION INSTRUCTIONS

KIT# 4408-1

11/4/13
KS

ROADMASTER, Inc. 6110 NE 127th Ave. Vancouver, WA 98682 360-896-0407 fax 360-735-9300 www.roadmasterinc.com

Supplemental trimming instructions for '11 to '13 Ford Edge models

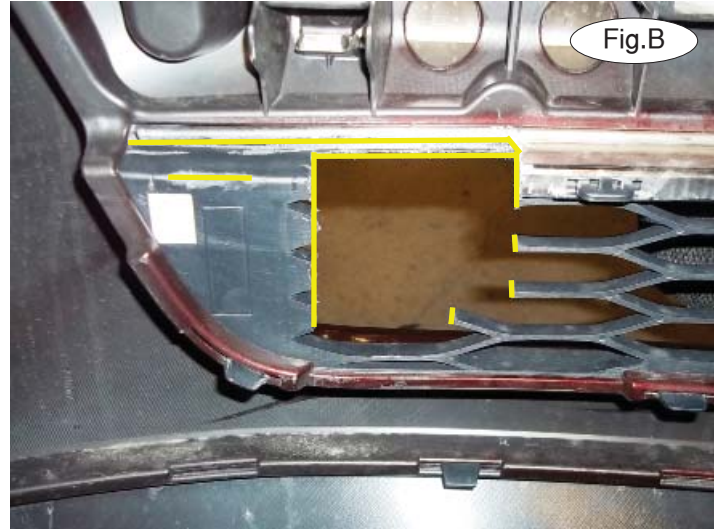
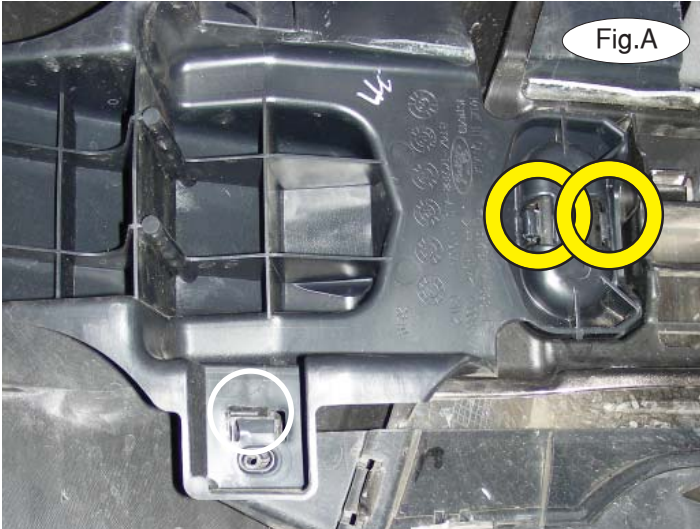

1. On each side, remove the outside bumper insert by releasing three plastic clips, if the vehicle is so equipped (Fig.A). *Note:* the bumper inserts will not be replaced. Retain the bumper inserts for replacement in case the bracket is ever removed.

2. Mark the fascia for trimming to allow clearance for the main receiver brace. Use the yellow lines in Figure B as a guide for trimming. *Note:* due to manufacturing variances, if your fascia is a solid pattern like the one shown in Figure C, use the yellow lines in Figure C as a reference for trimming the front of the fascia. Then, use the yellow lines in Figure B as a reference for trimming the back upper lip of the fascia.

Now, proceed to step 19 in the main instructions to finish this installation.

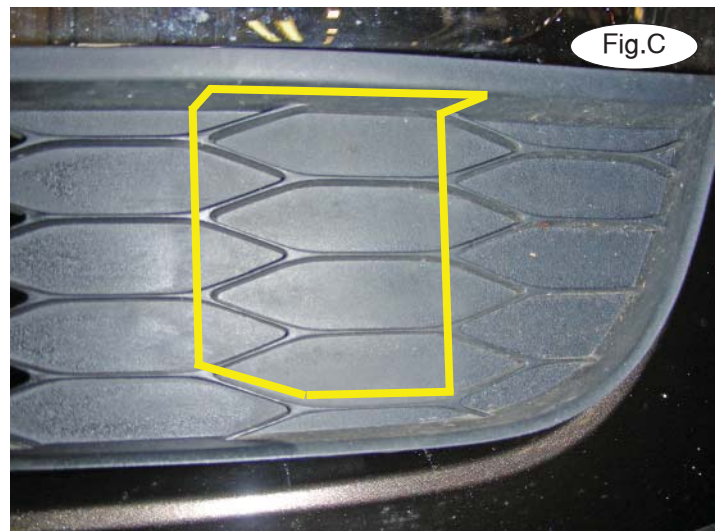



MOUNTING BRACKET KIT INSTALLATION INSTRUCTIONS

KIT# 4408-1

11/4/13
KS

ROADMASTER, Inc. 6110 NE 127th Ave. Vancouver, WA 98682 360-896-0407 fax 360-735-9300 www.roadmasterinc.com

Supplemental trimming instructions for 2.0 EcoBoost models

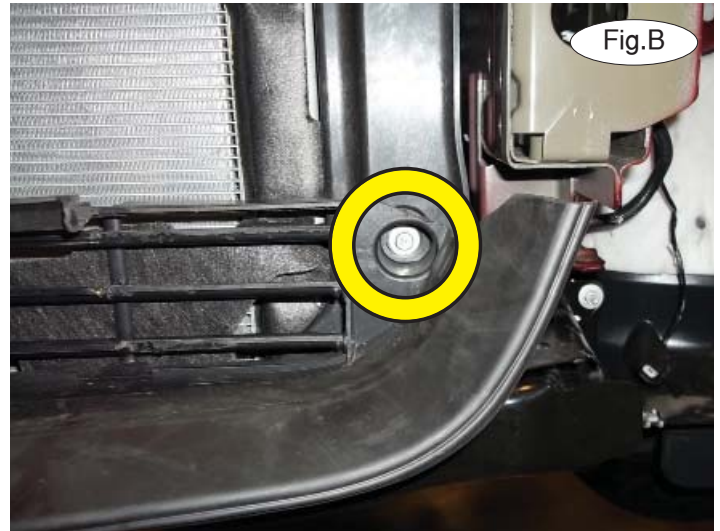
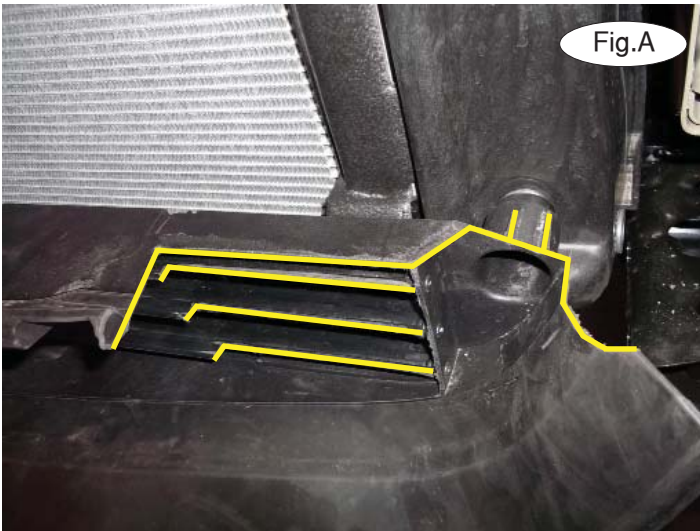

1. Trim ½" off the air shutters as shown in Figure A.
2. On each side, remove one 10mm nut (Fig.B) attaching the louver to the core support and two 10mm (head) bolts attaching the bumper to the core support.

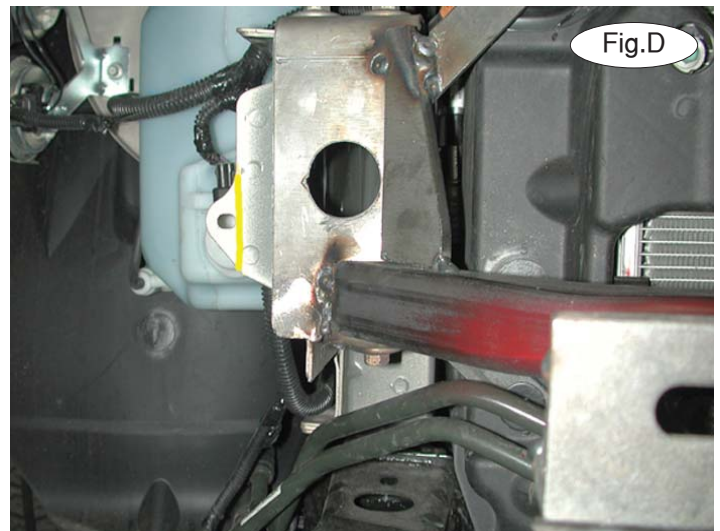

3. On each side, remove three 13mm (head) bolts attaching the bumper core to the frame rails (Fig.C). Next, remove the bumper core. *Note:* the bumper core will not be re-installed. Retain the bumper core and attachment hardware so that it can be replaced if the bracket is ever removed.
4. Trim the flange on the passenger side using the yellow marker line as a reference (Fig.D).



MOUNTING BRACKET KIT INSTALLATION INSTRUCTIONS

KIT# 4408-1

11/4/13
KS

ROADMASTER, Inc. 6110 NE 127th Ave. Vancouver, WA 98682 360-896-0407 fax 360-735-9300 www.roadmasterinc.com



5. Now, place the main receiver brace over the ends of the frame rails (Fig.E) and between the air shutters and core support (Fig.F).
 6. On each side, place a ¼" lock washer and fender washer over one of the supplied 6mm x 1.0 x 35mm bolts, and bolt through the air shutter mount, main receiver brace and into the core support.
- Now, proceed to step 12 in the main instructions to finish this installation.