

2" bore x 13" stroke x 1 1/2" rod.
 Max. operating pressure is 3000psi
 Paint black
 0.001 Min chrome plated rod.
 Operating temperature range: -40°F to 200°F
 Cylinder should be shipped with steel o-ring plugs in each port.

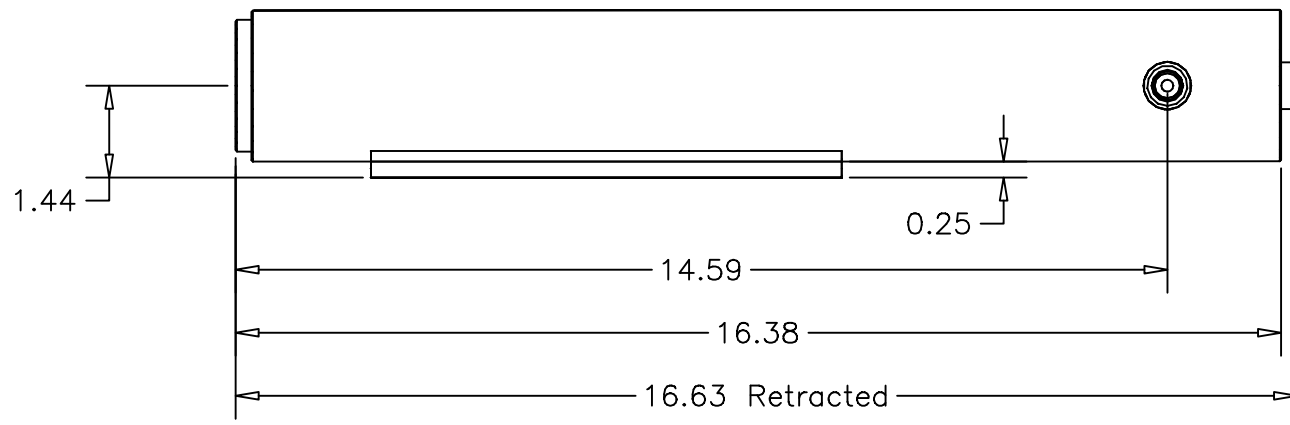

See sheet two for rod end details.

<i>Equalizer</i> 55169 COUNTY ROAD 3 ELKHART, IN 46515	#	REVISIONS			BY:	DATE:	UNLESS OTHERWISE SPECIFIED: TOLERANCES: .XXX ± 0.010 .XX ± 0.010 .X ± 0.030 ANG. ± 1/2" REMOVE ALL BURRS AND SHARP EDGES .015 MAX	TITLE		USED ON:	
								SL 13 CYLINDER	4 POINT LEVELING		
NOTICE - This drawing, including principles of design, is the property of Days Corporation, Elkhart, Indiana, with the agreement that it is not to be reproduced, copied, or loaned in any manner that may constitute a detriment directly or indirectly to Days Corporation. Acceptance of this will be construed as an agreement of the above.							SIZE	SCALE	MATERIAL		
							A	1: 1			
							DRW BY:	DATE:	PART NAME:		
							SJ	9/9/14	CYLINDER-SL 2 X 13 LP		
							APP'D BY	DATE:	PAGE:	DWG NO.:	REV:
							-	-	1 OF 2	3142A	-

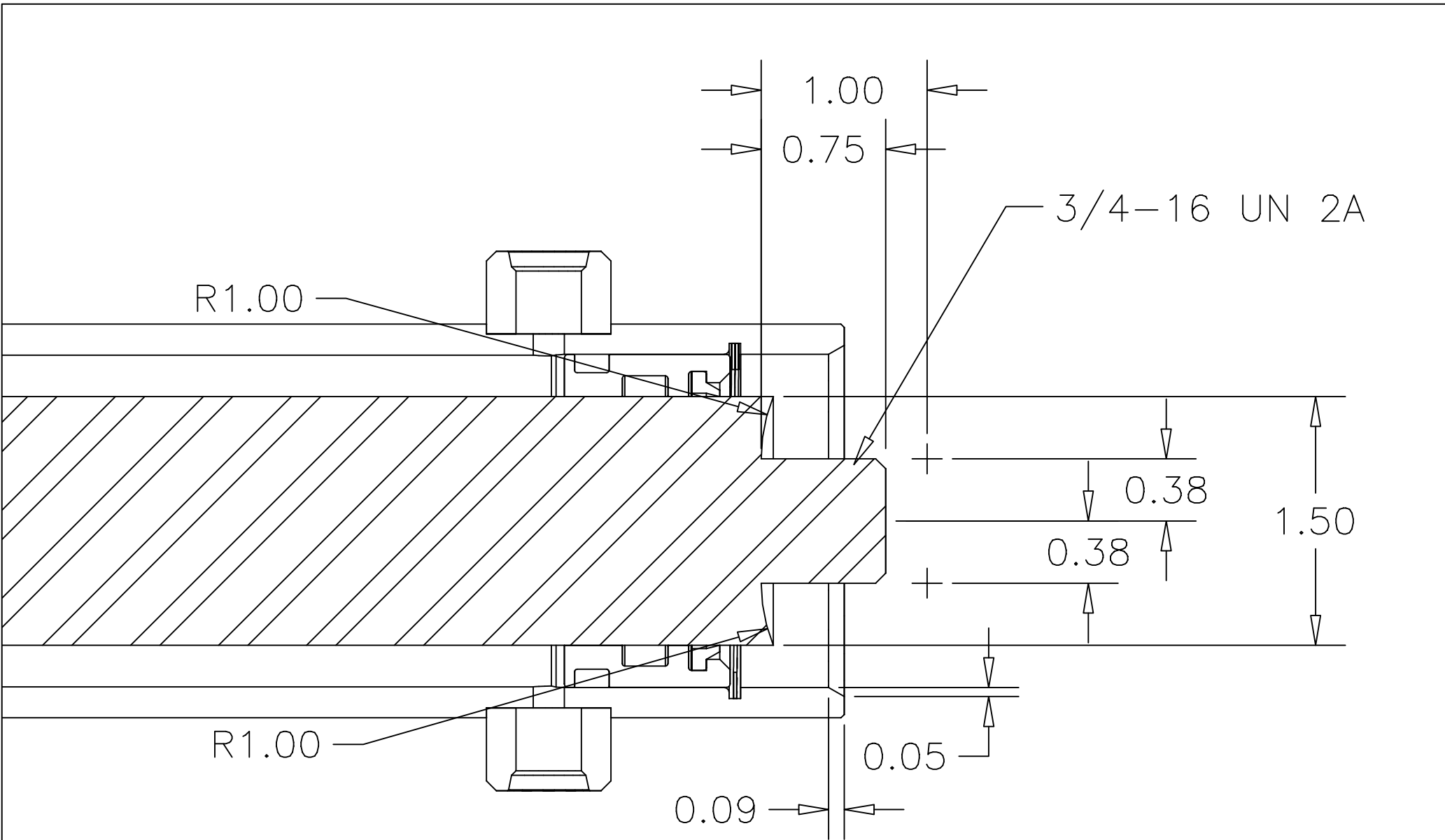

ROD DETAILS

Equalizer 55169 COUNTY ROAD 3
ELKHART, IN 46515

NOTICE - This drawing, including principles of design, is the property of Days Corporation, Elkhart, Indiana, with the agreement that it is not to be reproduced, copied, or loaned in any manner that may constitute a detriment directly or indirectly to Days Corporation. Acceptance of this will be construed as an agreement of the above.

#	REVISIONS	BY:	DATE:

UNLESS OTHERWISE SPECIFIED: TOLERANCES: .XXX ± 0.010 .XX ± 0.010 .X ± 0.030 ANG. ± 1/2"		TITLE SL 13 CYLINDER		USED ON: 4 POINT LEVELING	
REMOVE ALL BURRS AND SHARP EDGES .015 MAX		SIZE A 1:1	SCALE 1:1	MATERIAL	
DRW BY: SJ	DATE: 9/9/14	PART NAME: CYLINDER-SL 2 X 13 LP		PAGE: 2 OF 2	DWG NO.: 3142A
APP'D BY: -	DATE: -	REV:		-	