



BT12 Wireless Awning Control System

CONTROL SYSTEM FOR 12V MOTORIZED AWNINGS

USING BLUETOOTH® WIRELESS TECHNOLOGY



Read this manual before installing or using this product. Failure to follow the instructions and safety precautions in this manual can result in personal injury and/or cause the product to not operate properly.



The BT12 Wireless Awning Control System may be installed as part of the original motorized awning installation or as an upgrade to an existing motorized awning installation.

The system offers unique features not available with a standard awning installation.

- 1) Carefree Connects Mobile App – The app provides full and enhanced control of the awning using a smart phone or tablet. The free app can be downloaded on any devices that support: 1) Current iOS or Android operating systems, and 2) Bluetooth low energy technology.
- 2) Full Retract – When the awning is retracted, it retracts completely. It is not necessary to hold the button when closing the awning.
- 3) Full Extend – When the awning is extended, it extends completely. It is not necessary to hold the button when opening the awning.
- 4) Auto-Retract – The awning can be set to automatically close when windy conditions occur with the optional BT Motion Sensor.
- 5) Remote Control – The operator can conveniently operate the awning from any location with the optional BT Remote.

NOTICES AND DISCLAIMERS

TRADEMARKS

The **Bluetooth**® word mark and logos are registered trademarks owned by the Bluetooth SIG, Inc. Use of such marks by Carefree of Colorado is under license.

Other trademarks and trade names are those of their respective owners.

STATEMENTS OF COMPLIANCE

- BT12 Control Module
- BT Motion Sensor
- BT Remote

FCC and IC identification numbers are located on the exterior surfaces of the individual components.

FCC COMPLIANCE

These devices comply with Part 15 of the FCC rules. Operation is subject to the following two conditions: (1) These devices may not cause harmful interference and, (2) These devices must accept any interference received, including interference that may cause undesired operation.

NOTE: This equipment has been tested and found to comply with the limits for a Class B digital device, pursuant to part 15 of the FCC rules. These limits are designed to provide reasonable protection against harmful interference in a residential installation. This equipment generates, uses and can radiate radio frequency energy and, if not installed and used in accordance with the instructions, may cause harmful interference to radio communications. However, there is no guarantee that interference will not occur in a particular installation. If this equipment does cause harmful interference to radio or television reception, which can be determined by turning the equipment off and on, the user is encouraged to try to correct the interference by one or more of the following measures:

- Reorient or relocate the receiving antenna.
- Increase the separation between the equipment and receiver.
- Connect the equipment into an outlet on a circuit different from that to which the receiver is connected.
- Consult the dealer or an experienced radio/TV technician for help.

Any changes or modifications not expressly approved by the party responsible for compliance could void the user's authority to operate the equipment.

IC COMPLIANCE

These devices comply with Industry Canada license-exempt RSS standard(s). Operation is subject to the following two conditions: (1) These devices may not cause harmful interference and, (2) These devices must accept any interference received, including interference that may cause undesired operation.

Ces appareils sont conformes aux normes RSS exonérées de licence d'Industrie Canada. L'opération est soumise aux deux conditions suivantes: (1) Ces appareils ne doivent pas causer d'interférences nuisibles et, (2) Ces appareils doivent accepter toute interférence reçue, y compris les interférences pouvant entraîner un fonctionnement indésirable.

FCC/IC RADIATION EXPOSURE STATEMENT

- BT12 Control Module
- BT Motion Sensor

This equipment complies with FCC and IC radiation exposure limits for an uncontrolled environment. The minimum distance between the radiator and people is designed to be 20cm when installed and operated.

Cet équipement est conforme aux limites d'exposition aux radiations FCC et IC pour un environnement non contrôlé. La distance minimale entre le radiateur et les personnes est de 20cm lorsqu'installé et utilisé.

- BT12 Remote

This equipment complies with FCC and IC radiation exposure limits for an uncontrolled environment. The minimum distance between the radiator and people is designed to be 5mm when operated.

Cet équipement est conforme aux limites d'exposition aux radiations FCC et IC pour un environnement non contrôlé. La distance minimale entre le radiateur et les personnes est de 5mm (à l'exclusion des extrémités: mains, poignets, pieds et chevilles) lors de l'utilisation.

DISCLAIMERS

The BT12 Wireless Awning Control System and the Carefree Connects Mobile App are products of Carefree of Colorado, located in Broomfield, Colorado, USA. The information contained in or disclosed in this document is considered proprietary to Carefree of Colorado. Every effort has been made to ensure that the information presented in the document is accurate and complete. However, Carefree of Colorado assumes no liability for errors or for any damages that result from the use of this document.

The information contained in this manual pertains to the current components and software listed on the title page. Carefree of Colorado reserves the right to cancel, change, alter or add any parts and procedures, described in this manual, without prior notice.

Carefree of Colorado agrees to allow the reproduction of this document for use with Carefree of Colorado products only. Any other reproduction or translation of this document in whole or part is strictly prohibited without prior written approval from Carefree of Colorado.

SERVICE AND SUPPORT

	www.carefreeofcolorado.com/carefreeconnects
	customerservice@carefreeofcolorado.com
	<p>Carefree of Colorado 2145 W. 6th Ave. Broomfield, CO 80020</p>

TABLE OF CONTENTS

Installation 5

- BT12 Control Module Installation.....6
- Awning Switch Installation7
- Awning Lights Switch Installation.....7
- Wiring Diagram8
- Installing the BT Motion Sensor.....10
 - Altitude / Longitude / Latitude10
 - Eclipse / Travel'r10
 - Small Box Awnings.....11
 - Pairing the Motion Sensor11
- Setting the System into Pairing Mode.....12

Battery Replacement..... 13

- BT Motion Sensor13
- BT Remote.....13

FAQs..... 14

- The Indicator Light Blinks on the BT12 Control Box.14
- The System Beeps and the Awning Partially Retracts.14
- The Remote Does Not Work.....14

BT12 Wireless Awning Control Kits and Components 15

SAFETY INFORMATION



This is the safety alert symbol. It is used to alert individuals to potential personal injury hazards. Obey all safety messages that follow this symbol to avoid possible personal injury or death.



Indicates a hazardous situation, which if not avoided, could result in death or serious bodily injury.



Indicates a hazardous situation, which if not avoided, may result in minor or moderate bodily injury.



Indicates a situation that may result in equipment-related damage.

General Safety:



SHOCK HAZARD. Always disconnect battery or power source before working on or around the electrical system.



Always wear appropriate safety equipment (i.e. goggles).



Always use appropriate lifting devices and/or helpers when lifting or holding heavy objects.

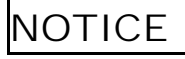

When using fasteners, do not over tighten. Soft materials such as fiberglass and aluminum can be "stripped out" and lose the ability to grip and hold.

INSTALLATION



WARNING SHOCK HAZARD. Always disconnect battery or power source before working on or around the electrical system.

Important Note: To comply with 2015 NFPA 1192 RV Standard, Section 6.4.9, switches must be mounted as follows:

- a) Installed in a dedicated switch cabinet with a latching door; or,
 - b) Installed with the optional covered bezel available from Carefree; or,
 - c) Installed in a cabinet with a latching door where the switch is protected and CANNOT be activated by any items or cargo that may move or shift during transit; or,
 - d) Installed with an interrupt circuit that disables awning extension when the vehicle is in motion.
1. The BT12 module provides an ignition lockout option. When the "IGN LOCK" is connected to the vehicle PCM or other switched source the following parameters are set:
 - i) If Open = Awning Active
 - ii) If tied to GND = RTL (Retract Then Lock) – Awning retracts, extend command disabled
 - iii) If tied to +12Vdc = Standard – Extend command disabled

To Start:

1. Determine the location for the awning switches, awning lights switch and BT12 control module.

NOTE: The BT12 control module leads are 6" in length. If the distance between the module and the switches is greater than 6", the installer must furnish splice wires for the extra distance. Use appropriate size wire gauges. Use appropriate sized butt splices to secure connections.
2. Route the motor cable and LED harness to the location of the module.

BT12 CONTROL MODULE INSTALLATION

(Refer to the wiring diagram on page 8.)

NOTICE Do not mount the unit near heat producing elements such as LP appliances or engine exhaust components.

NOTICE For best reception, do not mount the unit near or on a metal surface.

1. Clean the mounting surface. The surface must be flat and clean for the mounting tape to properly adhere.
2. Remove the release paper from the tape on the back of the module and firmly press the module onto the mounting surface.

NOTE: The module may be oriented for best fit with access to the wire leads.

3. Attach the motor wires (refer to diagram for corresponding wire colors) to the module leads for the motor using 14-16awg butt splices.
4. Run a minimum 14 awg wire to chassis ground. Suitable ground would be the vehicle chassis or conductive structure connected to the chassis. Splice the wire to the module GND lead with a 14-16awg butt splice.
5. Run a minimum 14 awg wire from the power distribution panel (auxiliary battery circuit) or equivalent. The circuit should be protected by a 15-amp fuse. Splice the wire to the module +12V lead with a 14-16awg butt splice.

NOTE: If the wire run is 30 feet or longer for +12Vdc and/or GND, use 12awg wire to prevent voltage drop. Use the appropriate butt splices for the wire size.

6. Splice the Black wire from the LED Harness to the module LED GND lead (Black) with a 18-22awg butt splice.
7. Route the module LED + lead (RED) to the awning lights switch location. Use 20awg wire and 18-22awg butt splice to extend the lead as necessary.
8. Route the module IGN LOCK lead (Green) to the vehicle PCM or other switch source (used for ignition lockout).
9. Route the remaining wires (Violet, Gray, Yellow and Brown) to the location for the awning control switches. Use 20awg wires and 18-22awg butt splices to extend the leads as necessary.

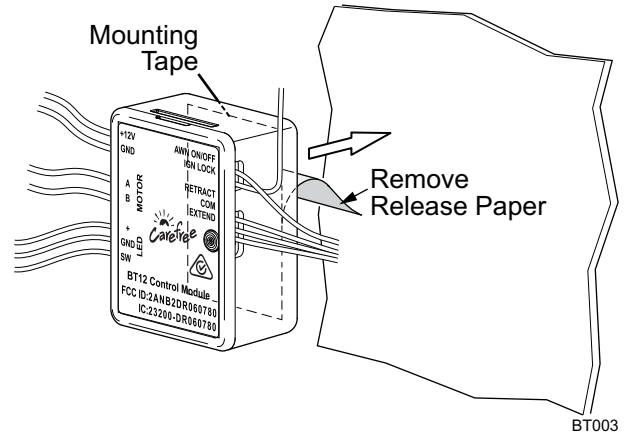

AWNING SWITCH INSTALLATION

(Refer to the wiring diagram on page 8.)

1. At the switch location cut a 2 5/16" [5.9cm] x 1 1/2" [3.8cm] hole.
2. From the module, terminate the three (3) 20awg wires (Brown, Yellow and Gray) with .187, 18-20 awg female terminals. Attach to the EXTEND/RETRACT switch as shown in the wiring diagram.
3. From the module, terminate the Violet wire with a .187, 18-20 awg female terminal. Attach to the ON/OFF switch.
4. Run a minimum 14 awg wire to +12VDC. Terminate the wire with .187, 14-16 awg female terminal and connect to the second terminal of the ON/OFF switch.

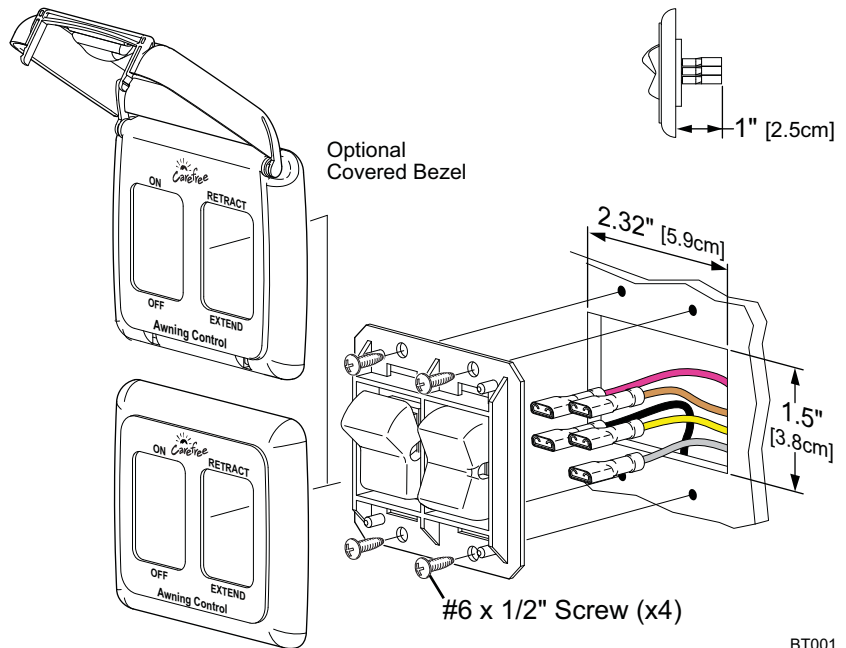

BT001

NOTE: If the wire run is 30 feet or longer, use 12awg wire to prevent voltage drop. Use the appropriate wire terminals for the wire size.

5. Push the wires and switches into the hole then attach the switch frame using 4 #6 x 1/2" screws.
6. Snap the switch bezel over the switch frame.

AWNING LIGHTS SWITCH INSTALLATION

NOTE: Carefree offers two switch options, unlighted and lighted. Installers may choose to furnish the control switch or may wire directly to a multiplexing control center.

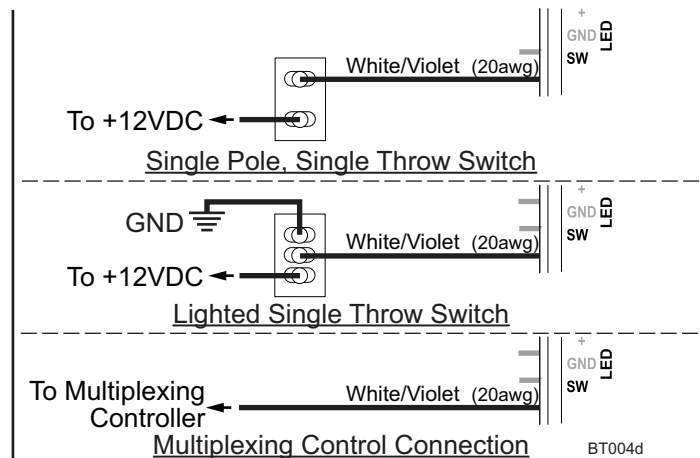
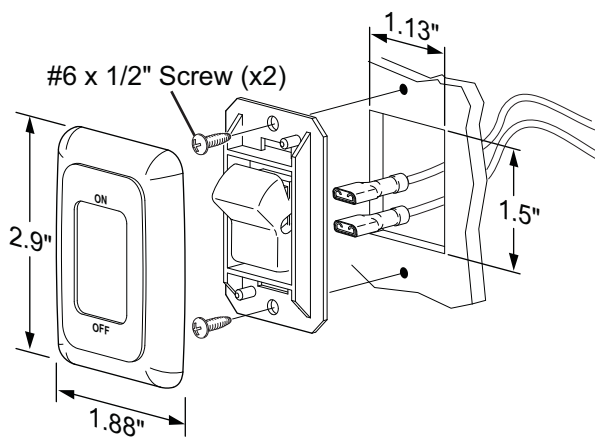

BT004d

1. Determine the location of the switch.
2. At the switch location, cut a 1 1/8" x 1 1/2" hole.
3. Wire the switch as shown. Wire terminals at the switch are .187, 18-24 awg female disconnects.

NOTE: The lighted switch has a third terminal. This is wired to GND.

WIRING DIAGRAM

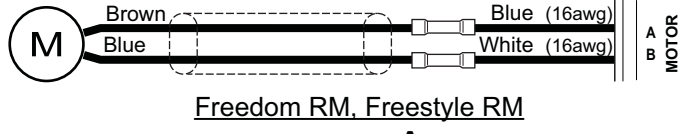
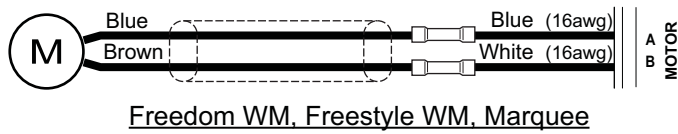
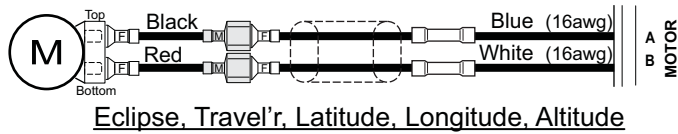
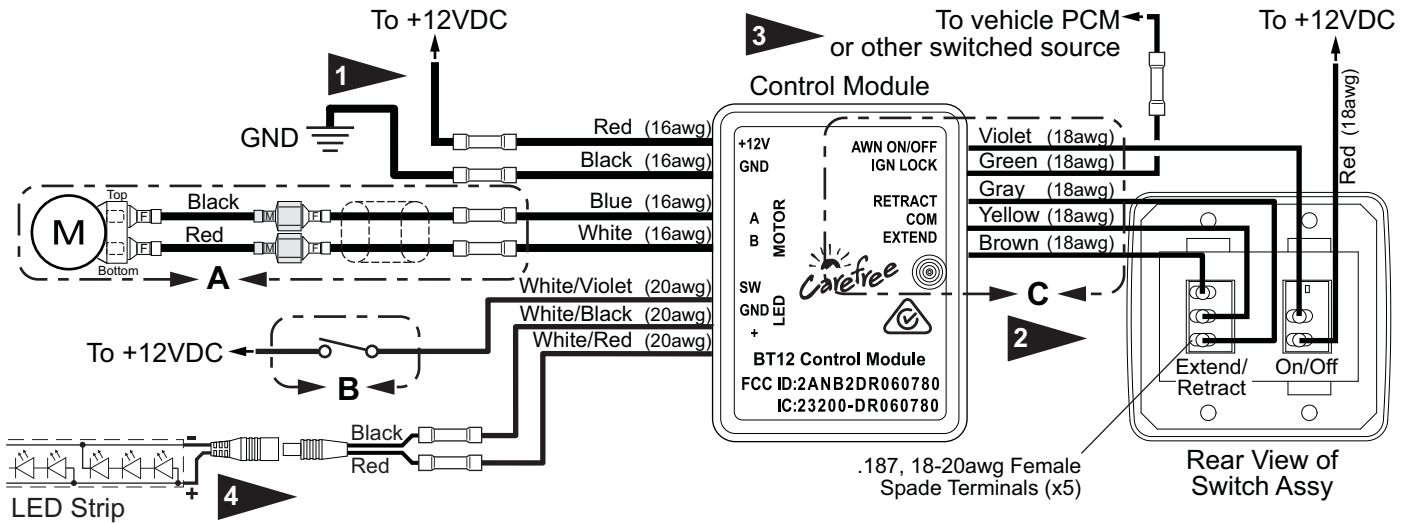

DETAIL A
Motor Connect

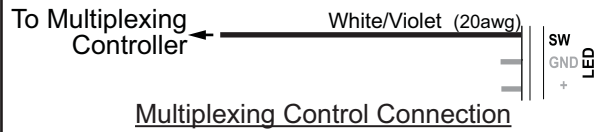
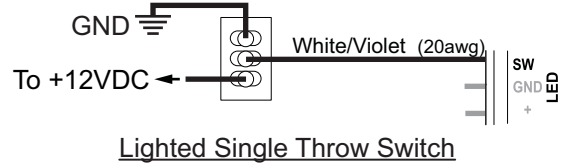
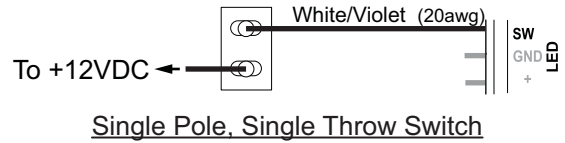

DETAIL B
Awning Lights Switch Options

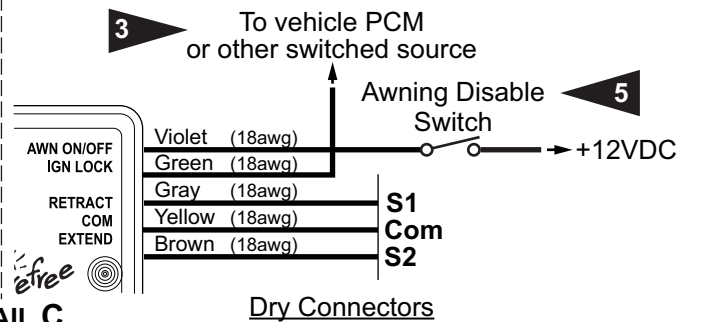
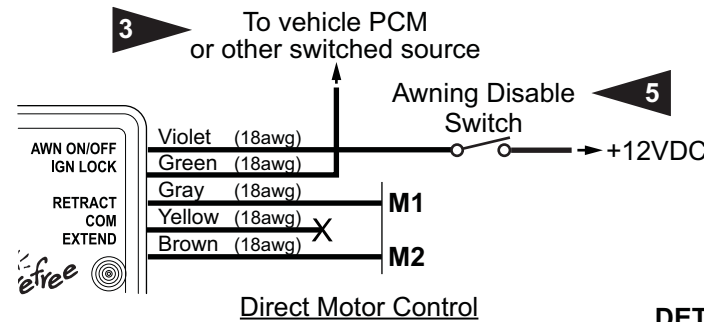

DETAIL C
Multiplex Control System

BT002e

- 1** For GND, run a minimum 14 awg wire to chassis ground. Suitable ground would be the vehicle chassis or conductive structure connected to the chassis.
For +12Vdc, Run a minimum 14 awg wire from the power distribution panel (auxiliary battery circuit) or equivalent. The circuit should be protected by a 15-amp fuse.
NOTE: If the wire run is 30 feet or longer, use 12awg wire to prevent voltage drop. Use the appropriate wire terminals for the wire size.
-
- 2** The BT12 module leads are 6" in length. If the distance between the module and the switch is greater than 6", the installer must furnish splice wires for the extra distance. Use appropriate size wire gauges. Use appropriate sized butt splices to secure connections.
-
- 3** The BT12 module provides an ignition lockout option. When the "IGN LOCK" is connected to the vehicle PCM or other switched source the following parameters are set:
- a) If Open = Awning Active
 - b) If tied to GND = RTL (Retract Then Lock) – Awning retracts, extend command disabled
 - c) If tied to +12Vdc = Standard – Extend command disabled
-
- 4** The LED connection is optional to provide LED controls through the app for white LEDs only. White LEDs can also be installed per the standard LED installation without BT12 Controls. RGB lights must be installed per the standard RGB installation.
-
- 5** The awning disable switch is a single throw; single pole switch used with OEM Multiplexing Control Systems. Switch is furnished by installer.

INSTALLING THE BT MOTION SENSOR

The system operates by gauging the motion of the awning's front edge (roller tube or lead rail). When the motion exceeds the preset threshold the system retracts the awning. The factory default is "3" on a scale from 1 to 5. When using the mobile app, the sensitivity can be adjusted for personal preference.

The sensor is located in the motor head for vertical arms or in the lead rail for box awnings.

Altitude / Longitude / Latitude

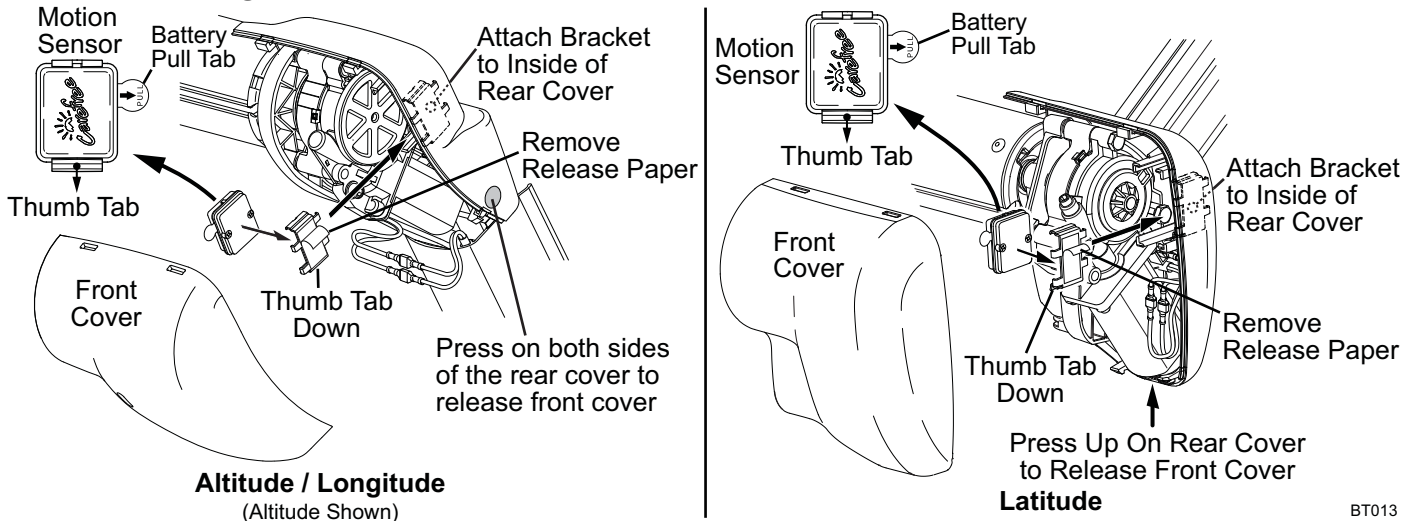

BT013

1. Remove the front cover on the motor side. The cover snaps onto the rear cover.
 - 1.1. *Altitude / Longitude*: Press in on both sides of the rear cover. Rotate the cover up and off.
 - 1.2. *Latitude*: Press the bottom of the rear cover until the front cover releases then lift the front cover off.
2. Clean the inside surface of the rear cover.
3. Remove the module from the bracket.
4. Remove the release paper from the mounting tape on the back of the bracket.
5. Firmly press the bracket onto the inner surface of the rear cover.

NOTE: If this is a replacement or a upgrade, do not install the module into the bracket until it is paired to the BT12 Control Module (page 11).

Eclipse / Travel'r

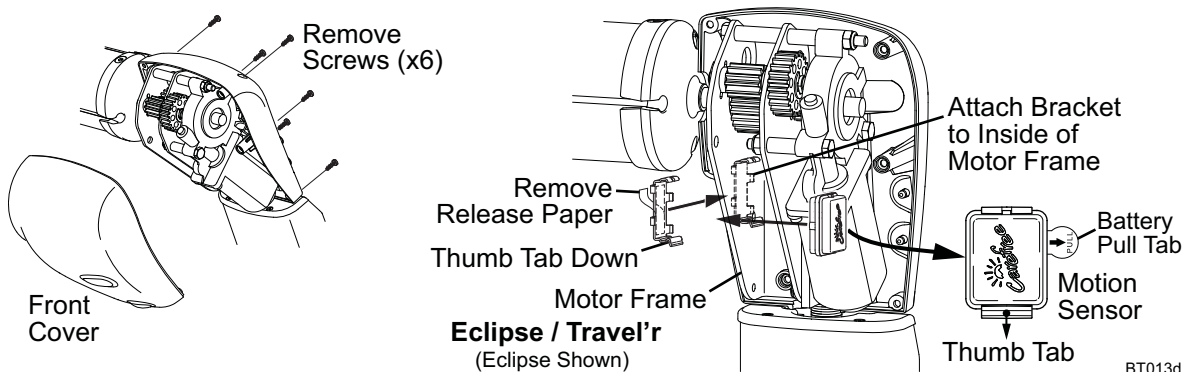

BT013d

1. Open the awning to access the screws in the rear cover.
2. Remove the six (6) small screws and front cover and set aside.
3. Clean the inside surface of the motor frame.
4. Remove the module from the bracket.
5. Remove the release paper from the mounting tape on the back of the bracket.
6. Firmly press the bracket onto the inner surface of the motor frame.

NOTE: If this is a replacement or a upgrade, do not install the module into the bracket until it is paired to the BT12 Control Module (page 11).

Small Box Awnings

This option is available for Freestyle WM and Freestyle RM. It is not available for the Freedom WM, Freedom RM or Marquee.

7. Open the awning to expose the inside of the lead rail on the motor side.
8. Clean the inside surface of the lead rail.
9. With the module bracket oriented horizontally, as shown, remove the release paper from the mounting tape.
10. Firmly press the bracket onto the inner surface of the lead rail between the end plate and arm connector on the motor side of the awning.

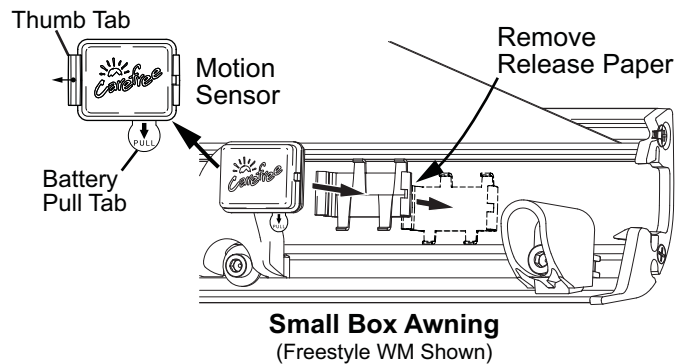

BT013c

NOTE: If this is a replacement or a upgrade, do not install the module into the bracket until it is paired to the BT12 Control Module (page 11).

Pairing the Motion Sensor

NOTE: Only 1 active motion sensor can be paired to the BT12 Control Module.

1. After completing the bracket installation, restore power to the awning and extend the awning using the switches.
2. Place the awning in pairing mode (refer to page 12).
3. Remove the battery pull tab from the motion sensor.
4. Hold the motion sensor next to the control module for 2-3 seconds. The module should be paired.
5. Holding the sensor vertically with the Carefree logo upright, repeatedly move the sensor vertically up and down to simulate a brisk wind. The awning should retract.
6. Snap the module in the mounting bracket. The module will only fit one way in the bracket.
7. *For Altitude / Longitude / Latitude:* Snap the front cover onto the rear cover. Hang the cover on the top and swing down until it clicks.
8. *For Travel'r / Eclipse:* Install the front cover with the screws removed previously.

SETTING THE SYSTEM INTO PAIRING MODE

Kit components for the BT12 Control System are paired at the factory for simplified installation.

NOTICE Ensure that the kits are kept together and not mixed with other kits. The pairings are unique to each control module.

To put the system into pairing mode for the mobile app and/or additional peripherals that may be added (i.e. additional remotes), follow the directions below:

NOTE: The illustration shows the standard Carefree switches. Some OEM's may choose to furnish their own switches or incorporate the power and Extend/Retract controls in a multiplexing control system. The following directions are valid for all configurations.

1. Turn power to the awning ON.
2. Extend the awning. Note that the awning does not have to be opened completely.
3. Retract the awning.
4. When the awning is fully retracted, press and hold the retract switch for 3 seconds.
 - 4.1. The awning is now in pairing mode for 5 minutes.



Press and Hold the Retract Button for 3 Seconds After the Awning has Fully Retracted

BTA001b

5. The BT12 control module will automatically pair to the device then go to working mode.

NOTES:

- The module will pair to the physically closest unpaired device first. Repeat the pairing steps for each additional device (the module remembers the devices that have been paired).
- Refer to the Carefree Connects Mobile App manual for setting up and pairing a smart device (such as a smart phone or tablet).
- Multiple devices can be paired to the awning up to a maximum of 8 peripheral devices.
 - Only one active BT Motion Sensor can be paired to the BT12 Control Module.
 - Only one active BT Remote can be paired to the BT12 Control Module.
 - Multiple mobile devices (smartphone or tablet) can be paired to the BT12 Module but only 1 can be active at a time.

Testing the Remote Functions:

1. Turn the awning and Awning Lights power switches ON.
2. On the remote, press and release the extend button. Press a second time to stop the awning motion.
3. Repeat for the retract button.

NOTE: The LED controls are for White LED strips that are wired to the BT12 module.

4. Extend the awning so that the LED strip is visible.
5. Turn the awning lights power switch ON.
6. Press the ON/Off button to turn the LED's on and off.
7. Press the LED Bright to brighten the LEDs. Press the LED Dim to lower the LED's

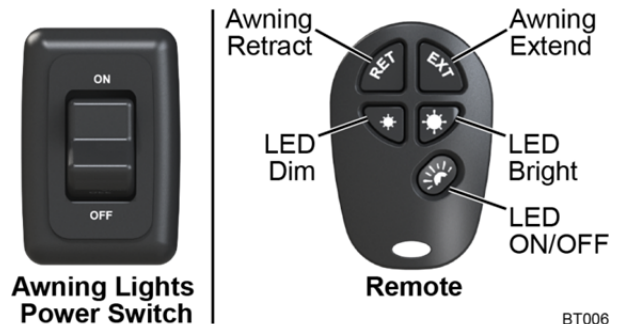

BT006

BATTERY REPLACEMENT

BT MOTION SENSOR

If the motion sensor batteries are low, the awning will beep every 30 seconds (when the power switch is ON) and the awning will partially retract. This will continue until the batteries are replaced. The awning will operate normally after the batteries are replaced.

The motion sensor uses two (2) 675 batteries; batteries are available at local battery outlets.

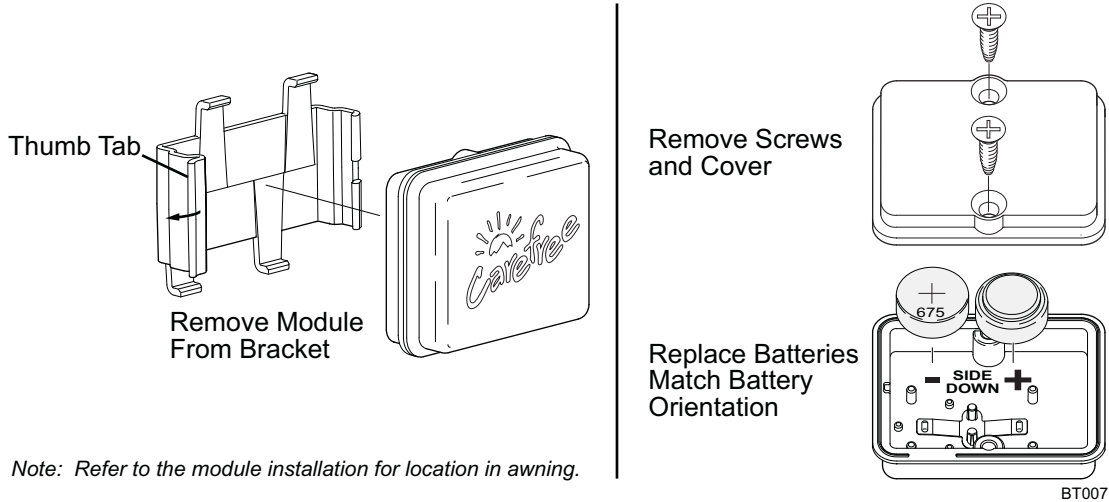

1. Pull the thumb tab of the bracket away from the module and lift the module out of the bracket. NOTE: It is not necessary to remove the mounting bracket.
2. Remove the two screws and the rear cover.
3. Replace the two batteries. Match the new battery orientation with the old batteries.
4. Replace the cover and screws.
5. Snap the module into the mounting bracket. The module will only fit one way in the bracket.

BT REMOTE

The remote uses one (1) CR2032 battery; batteries are available at local battery outlets.

1. Carefully remove the back cover using a coin in the slot at the bottom corner of the remote.
2. Remove the old battery and insert a new battery with the “+” terminal facing up.
3. Snap the back cover on.

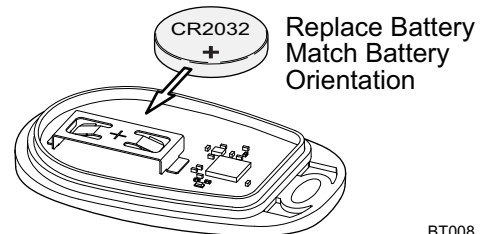
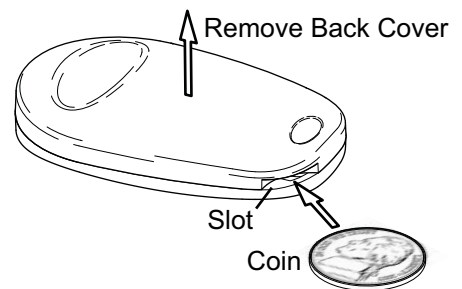

FAQS

THE INDICATOR LIGHT BLINKS ON THE BT12 CONTROL BOX.

- The indicator light on the control module shows the function status of the control module.
- Solid ON indicates power is supplied to the control module.
- One long blink and one short blink indicates power and 1 peripheral (i.e. remote or motion sensor) is paired to the module.
- One long blink and multiple short blinks indicates power and multiple peripherals are paired to the module. The number of short blinks is based on the number of peripherals paired.
- The module does not blink for being paired to the app.

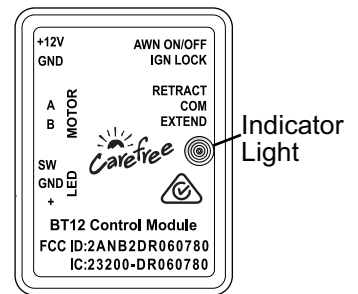

BT023

THE SYSTEM BEEPS AND THE AWNING PARTIALLY RETRACTS.

- The motion sensor batteries are low, the awning will beep every 30 seconds (when the power switch is ON) and the awning will partially retract. This will continue until the batteries are replaced. The awning will operate normally after the batteries are replaced. Battery replacement is described on page 13 and in the awning's owner manual.

THE REMOTE DOES NOT WORK.

Confirm that the remote is paired. The module indicator light will blink when peripherals are attached (see description above).

In the mobile app on the "Peripherals Page" confirm that the remote is connected. Green indicates the remote is connected, red indicates device is paired but not connected. No listing indicates the remote has not been paired.



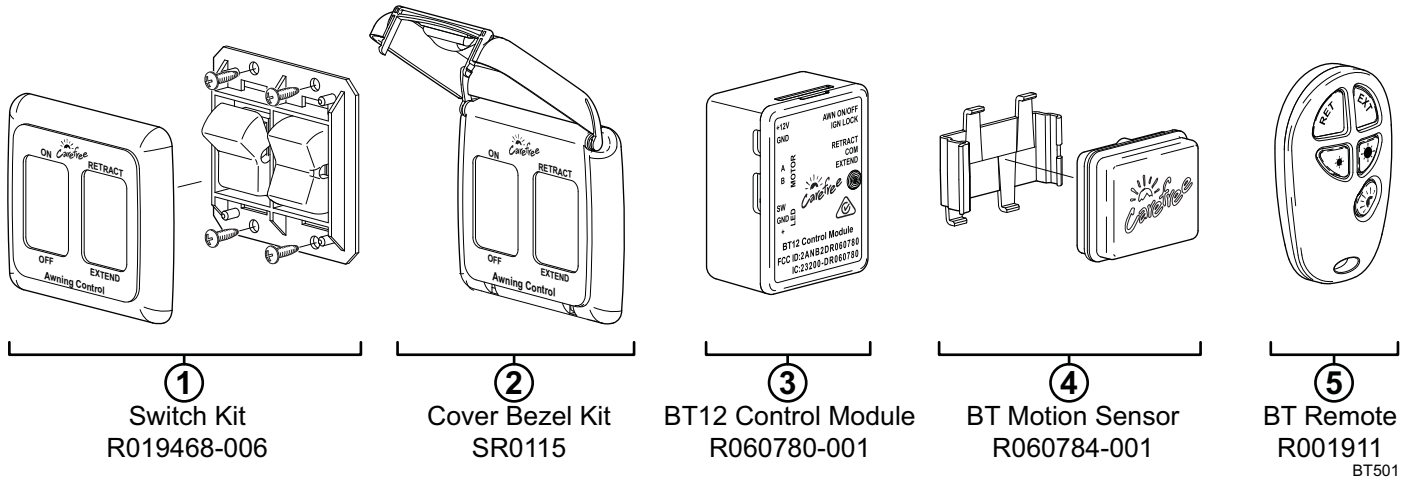

- Remote not paired. Refer to page 12 to pair the device.
- Remote is paired but not active. The remote has an approximate operating range of 30 feet depending on obstructions (such as walls and other vehicles). Move closer to the awning and control module.
- Remote is paired but not active. Batteries need to be replaced. Battery replacement is described on page 13 and in the awning's owner manual.

BT12 WIRELESS AWNING CONTROL KITS AND COMPONENTS

The following kits and components are available for the BT12 Wireless Awning Control System



AVAILABLE UPGRADE KITS

Kit Number	Included Components				
	① 	② 	③ 	④ 	⑤ 
R001911					Included
SR0115		Included			
901600	Included		Included		Included
901601	Included		Included	Included	
901602	Included		Included		

NOTES: Kits are paired at the factory. Separate components that are added or used for replacements must be paired to the existing control module.