



# Easi-Move

Model Number:V4



## User Manual

# Package Contents

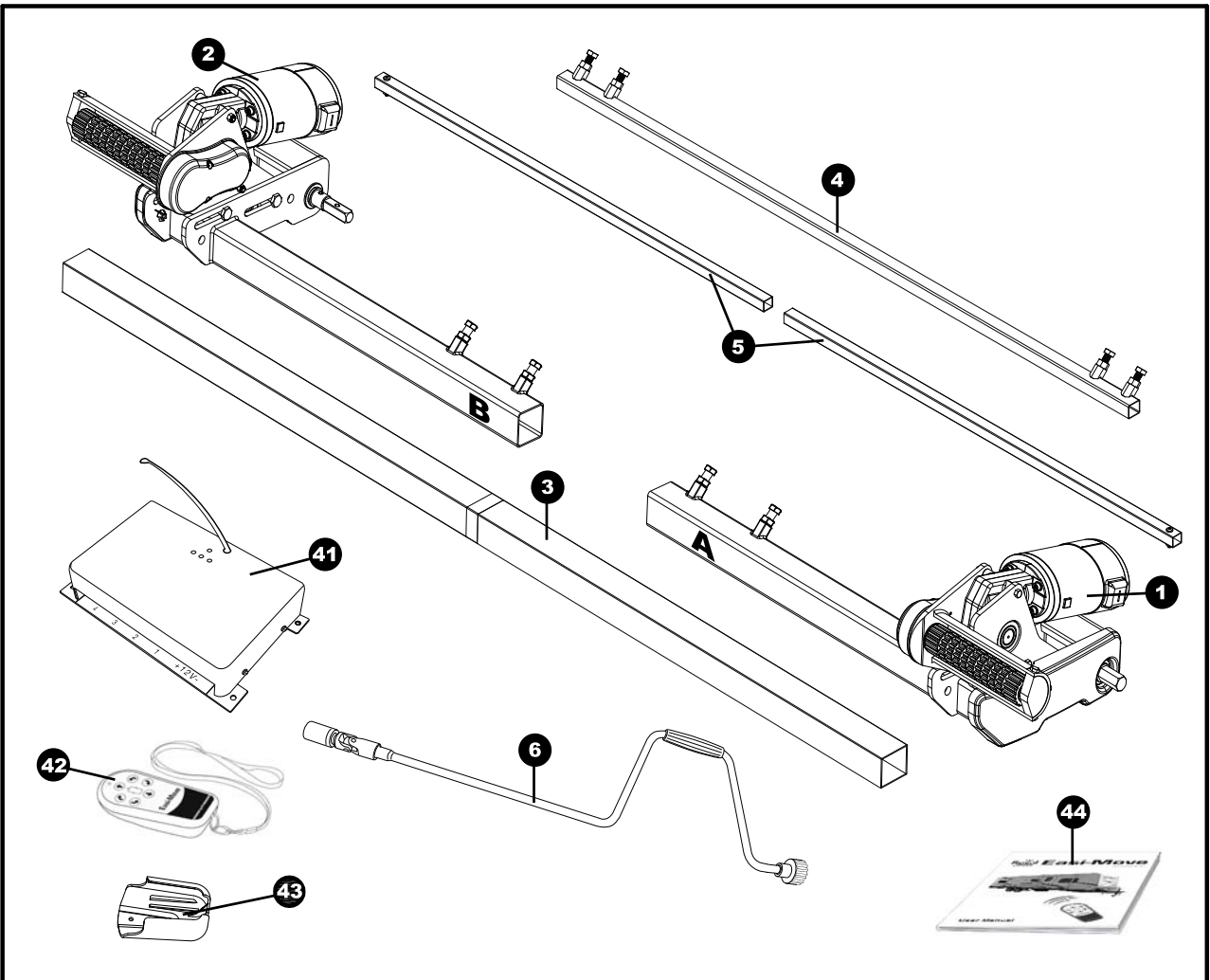

<p>7</p>	<p>8</p> <p>9</p> <p>10</p>	<p>11</p> <p>12</p>	<p>13</p>	<p>14</p>
<p>15</p>	<p>16</p> <p>17</p>	<p>18</p> <p>19</p> <p>20</p> <p>21</p> <p>22</p> <p>23</p>	<p>24</p> <p>25</p> <p>26</p> <p>27</p>	<p>28</p> <p>29</p> <p>30</p> <p>31</p>
<p>32</p> <p>33</p>	<p>34</p> <p>35</p>	<p>36</p> <p>37</p>	<p>38</p> <p>39</p>	<p>40</p>

# Parts Identification & Fitting Diagrams

Fig.1

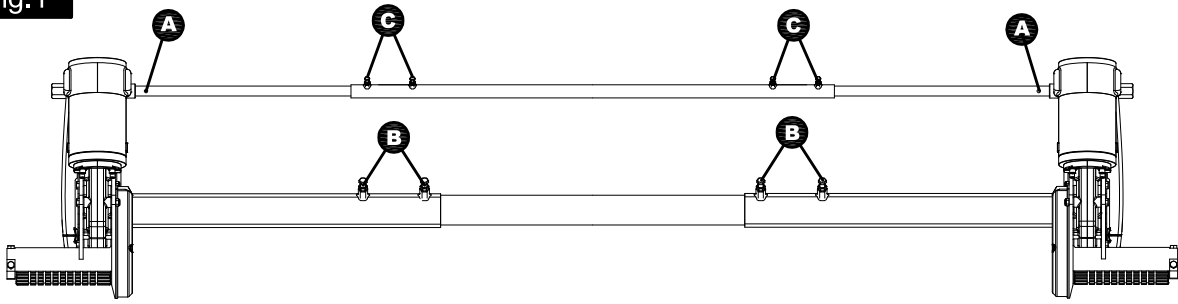

Fig.4

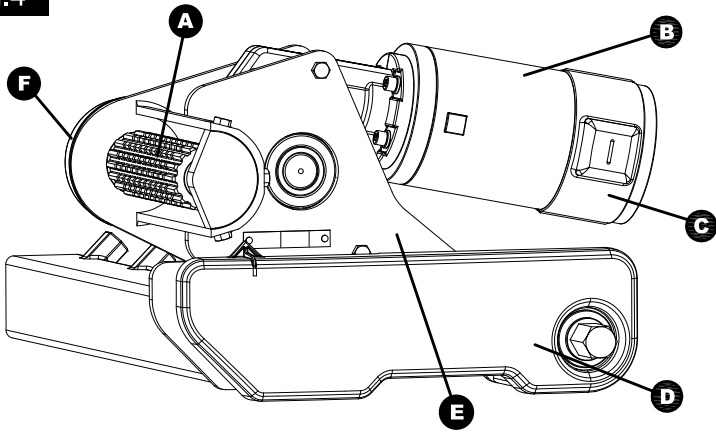

Fig.5

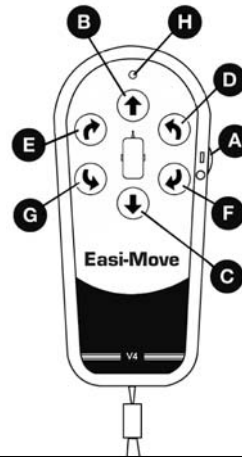

Fig.9

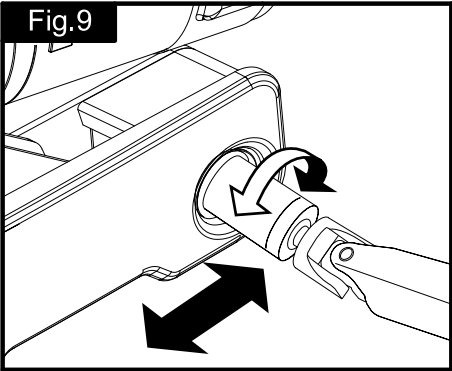

Fig.10

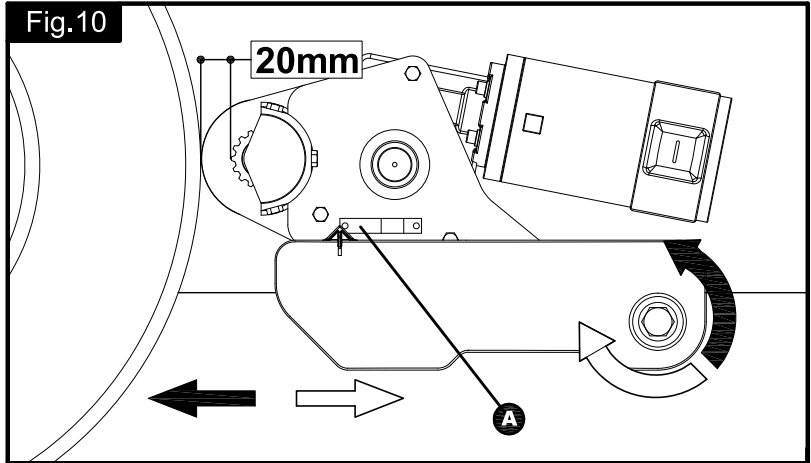

Fig.8

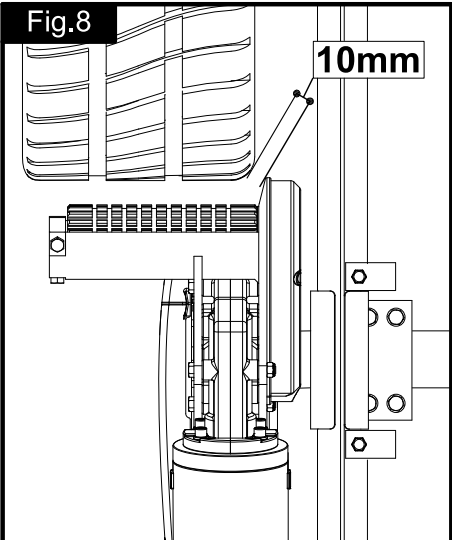
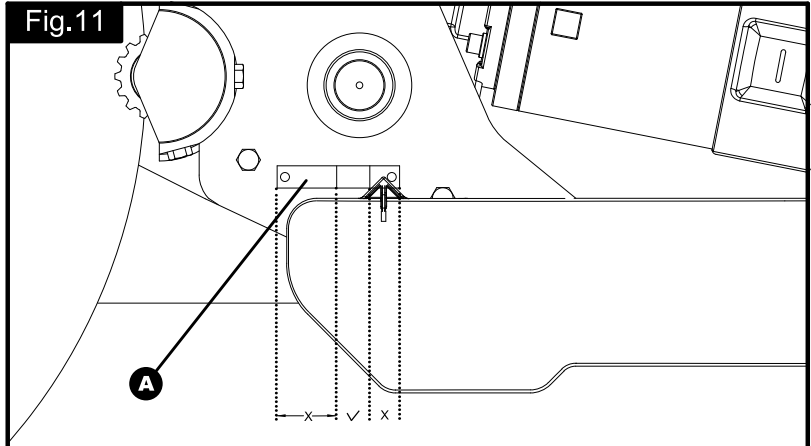

Fig.11



# Parts Identification & Fitting Diagrams

Fig.2

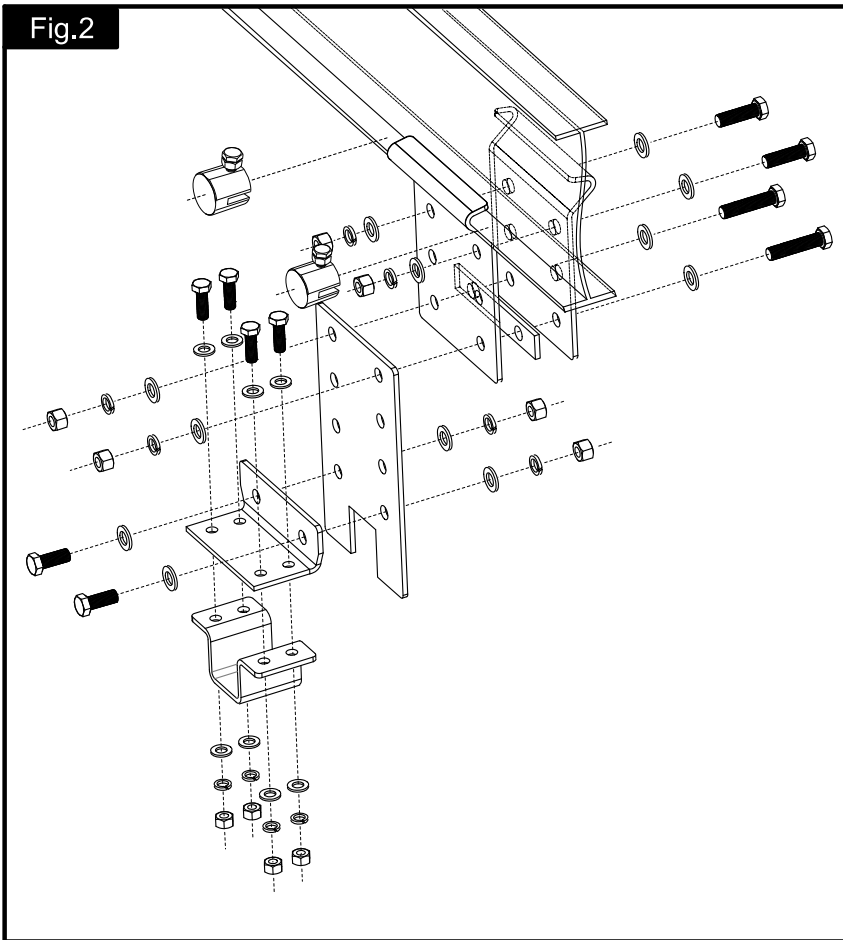

Fig.3

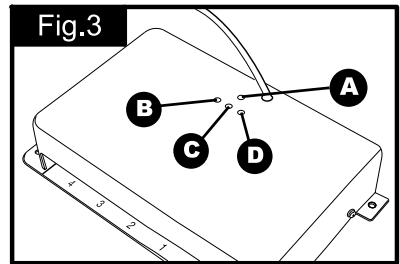

Fig.7

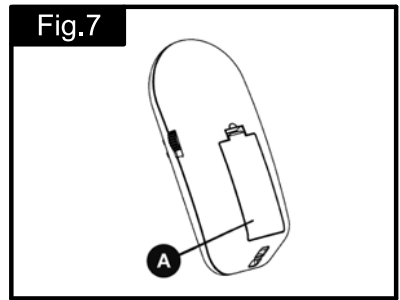

Fig.7.1

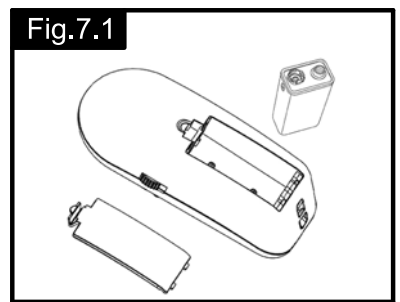

Fig.2.1

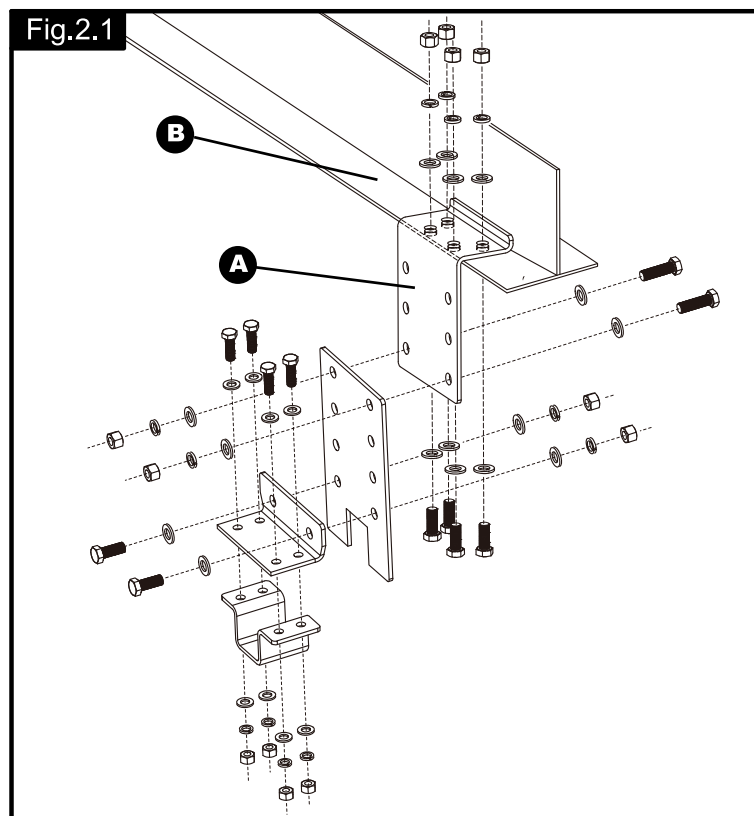
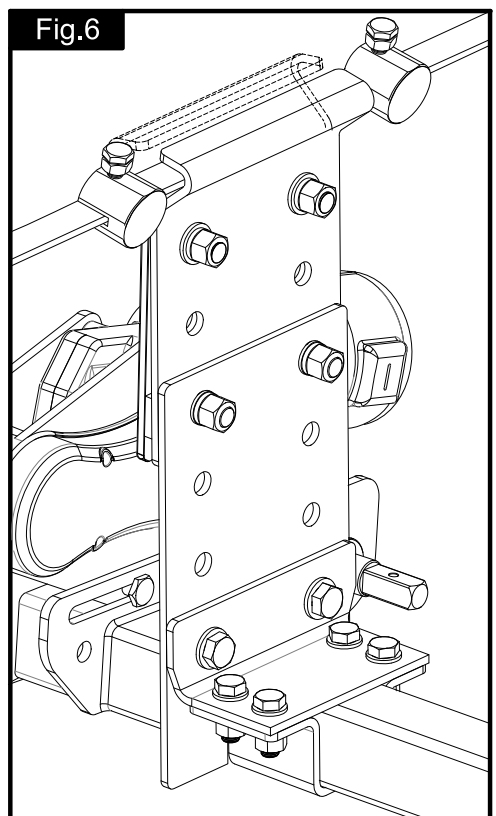

Fig.6



# Parts Identification & Fitting Diagrams

Fig.12

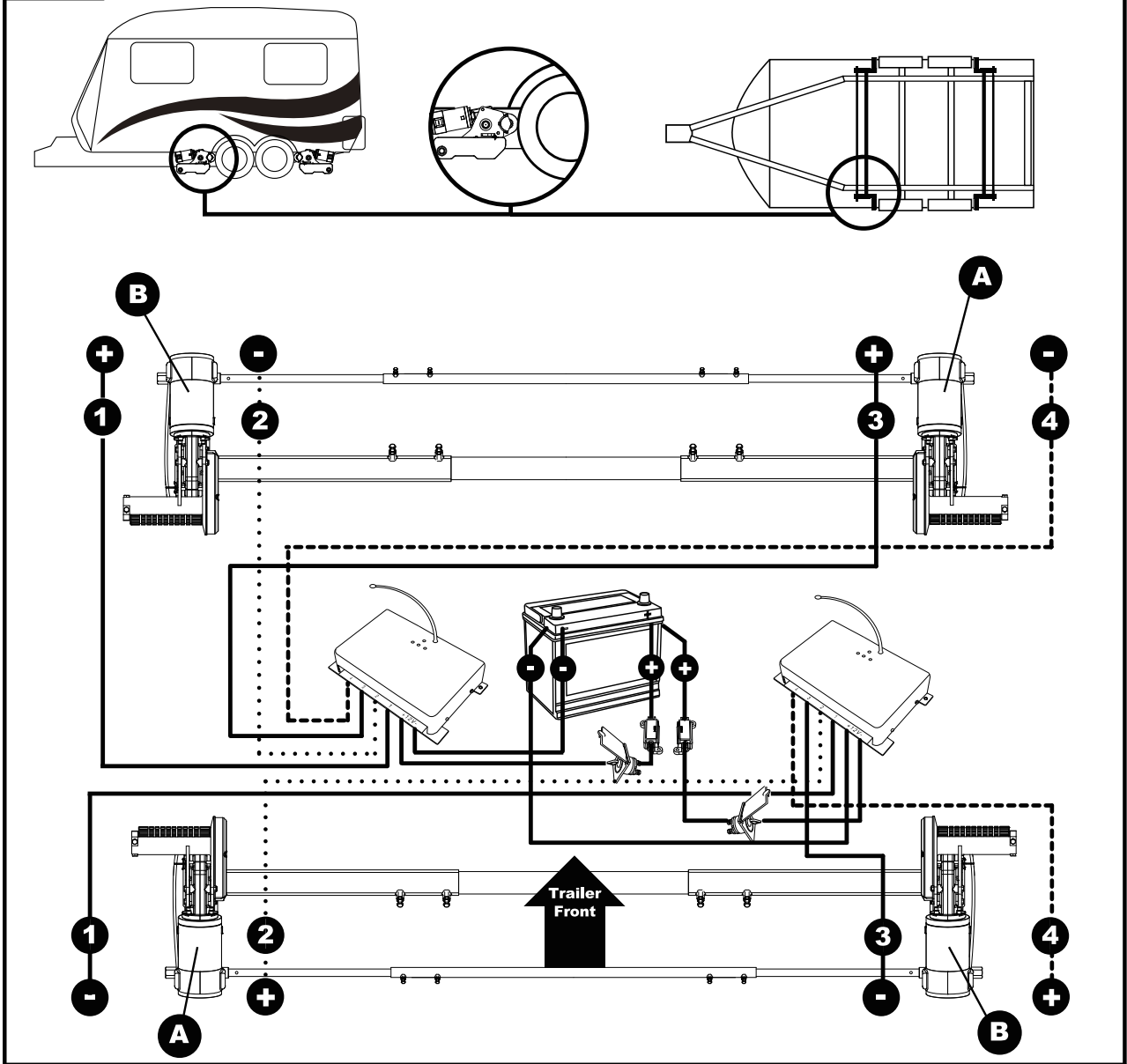
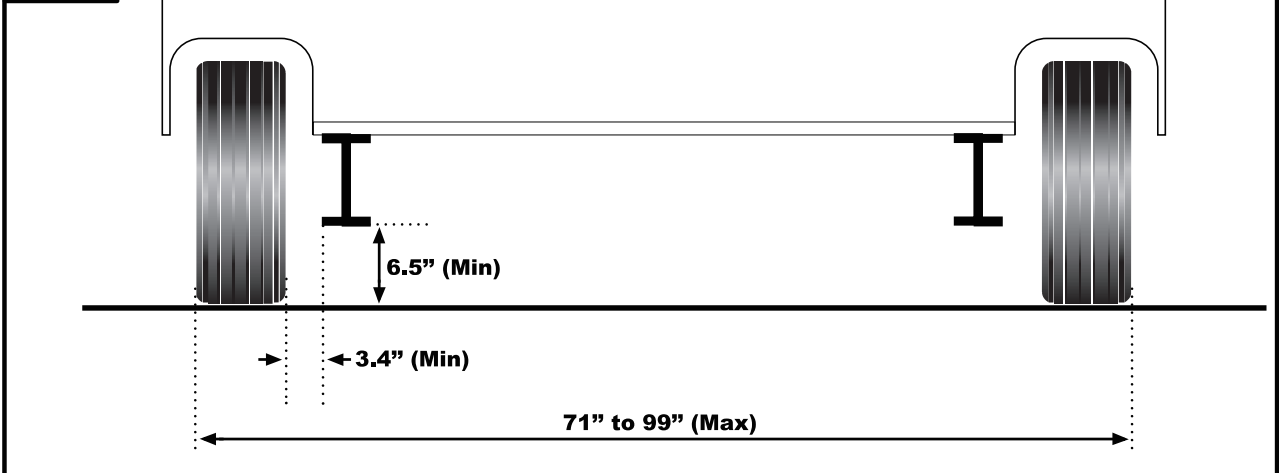

Fig.13



## Guarantee

This product is covered by a 12 months parts guarantee, if fitted correctly, in accordance with the fitting instructions.

Please note that our guarantee covers reasonable use of the maneuvering system, it does NOT cover any damage caused by misuse. This also applies to a malfunction or failure of the maneuvering system that has been caused by poor or incorrect installation.

To ensure the validity of the guarantee please carry out maintenance in accordance with the maintenance section. We reserve the right to make a call out and/or repair charge for any work required to be undertaken to rectify faults that are outside of the company's control i.e. battery failure, incorrect or poor fitting, misuse, accidental damage, etc.

Please Note: It is important that you register your Easi-Move within 30 days of installation. You can register on-line at [www.easi-move.com](http://www.easi-move.com) or by completing the form below and return to Unipart Leisure & Marine, 3620 Royal South Parkway, Atlanta, Georgia, 30349

Royal Easi-Move-Trailer manoeuvring system Serial No. (on top of motor unit)	<input type="text"/>
Date of Purchase	
Name of Dealer	



product **registration**

**Royal Easi-Move**

Royal Easi-Move-Trailer manoeuvring system Serial No.	<input type="text"/>
Date of Purchase	
Name of Dealer	
Dealer Address	
Zip Code/Postcode	

Your Name	
Your Address	
Zip Code/Postcode	

Please return this slip to the address overleaf within 14 days of purchase

## Contact Information

Unipart Leisure (USA)  
3620 Royal South Parkway  
Atlanta, Georgia 30349  
USA  
Tel:  
Email: [info@easi-move.com](mailto:info@easi-move.com)  
Website: [www.easi-move.com](http://www.easi-move.com)



AFFIX  
STAMP  
HERE

 **Easi-Move**