



Demco Tow Bar Adapter Bracket

for StowMASTER™ Base Plates

BASE PLATE

BOLT TORQUE SPECIFICATIONS

STANDARD BOLTS:			METRIC BOLTS:	
Size	Grade	Torque	Size	Torque
5/16"	5	20 ft/lbs.	8mm	22 ft/lbs.
3/8"	5	35 ft/lbs.	10mm	42 ft/lbs.
7/16"	5	56 ft/lbs.	12mm	70 ft/lbs.
1/2"	5	85 ft/lbs.	14mm	95 ft/lbs.

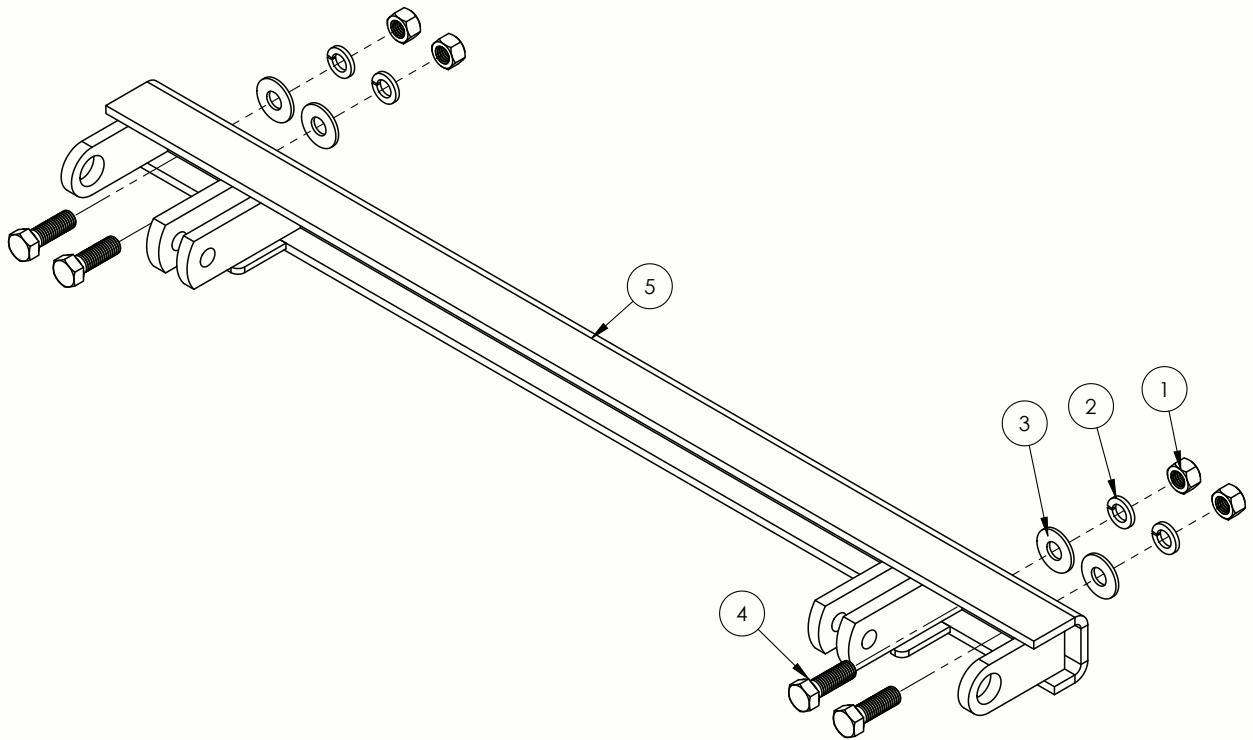

9523001 PARTS LIST

REF. NO.	PART NO.	QTY.	DESCRIPTION
1.	00083	4	1/2"-13UNC Hex Nut
2.	00084	4	1/2" Lockwasher
3.	00085	4	1/2" Flatwasher
4.	01254	4	1/2"-13UNC x 1-1/2" Hex Bolt Gr.5
5.	07316-35	1	Tow Bar Adapter Bracket (Excalibar, Aluminator, and Kwik-Tow)

Please order replacement parts by **PART NO.** and **DESCRIPTION.**

ASSEMBLY
OPERATION
REPLACEMENT PARTS

READ complete manual *CAREFULLY*
BEFORE attempting operation.

Doing Our Best to Provide You the Best



SAFETY

Safety is of utmost importance at all times. There are several items that must be checked each time before using and while using a tow bar.

Before allowing anyone to hook up or operate a tow bar, be sure they have read and understand the proper operating procedure.

DO NOT use worn or damaged cables and/or pins.

Be sure the **SAFETY CABLES** are hooked to both the towing and towed vehicles using the criss-cross method.

Check clearance between vehicles in a turning situation.

Check base plate mounting bolts for tightness and frame for metal fatigue.

Do not load the towed vehicle with anything as you may exceed the towing capacity of the tow bar.

Keep fingers away from pivot points to prevent personal injury.

Be sure the steering components of the towed vehicle are properly aligned.

NOTE: This unit can be backed up in moderate increments. Any severe backwards cornering could result in damage to the Tow Bar and/or towed vehicle chassis.

For automatic transmissions: Consult your vehicle owners manual for towing suitability with the drive shaft connected. Otherwise, the towed vehicle will have to be equipped with a transmission pump or drive shaft disconnect.

Check to make sure that all lights are in proper working order.

Make sure the optional light bar is fastened securely at the rear of the towed vehicle.

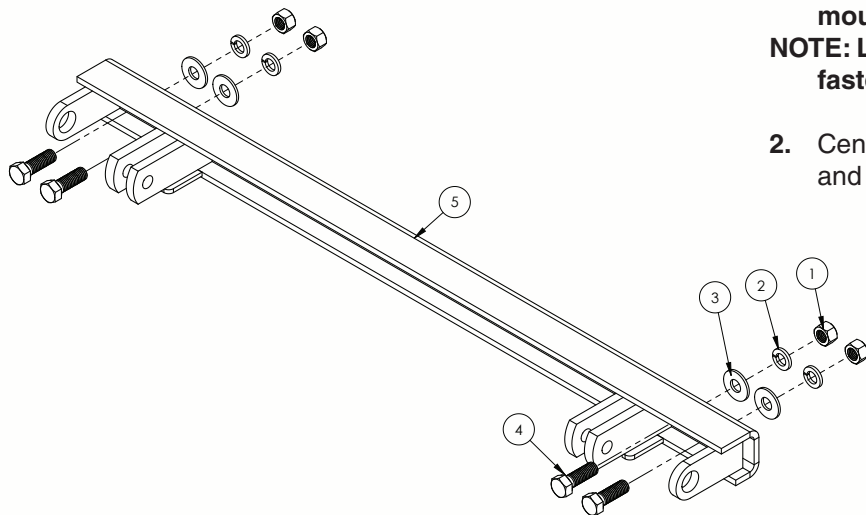

IMPORTANT INSTALLATION ITEMS

DEMCO products and accessories are intended to be installed by professional installers with experience, proper equipment and the ability to do modification work. Installers with these qualifications can be found in RV and Automotive Service Centers.

If the car to be towed has been in an accident, the chassis may be damaged in an area where the Base Plate attaches. It may no longer be suitable for towing. Extreme caution and careful examination are required in such a situation. It is also likely, even from a minor accident, that the hole alignment will be more difficult due to hole alignment problems.

Many DEMCO Base Plates are designed to use existing holes and hardware to mount the Base Plate to the towed vehicle. Even though the bolt is there however, do not assume it is adequate for mounting the Base Plate. Manufacturers make many changes in hardware both within and between model years. Be sure the bolt is long enough to protrude past the nut a distance no less than 1/2 the diameter of the bolt, after the Base Plate is mounted. The threads should be in good condition. **We require that "Locktite Blue" be used on all bolts.** If a new bolt is required, be sure it is SAE Grade 5 or Metric 8.8.

INSTALLATION INSTRUCTIONS

1. Loosely install Adapter Bracket onto base plate mounting brackets using four 1/2" x1-1/2" hex bolts, flatwashers, lockwasher and hex nuts.

NOTE: Flatwashers are located next to the slotted holes on the base plate mounts.

NOTE: Locktite Blue must be used on all fasteners.

2. Center adapter bracket on baseplate and tighten all bolts.