

- CT - POWDER COAT BLACK
 - CTG - POWDER COAT GRAY

- SEE PAGE 2 FOR PART NUMBER CHART
 AND DIMENSIONAL INFORMATION

- SEE PAGE 3 FOR REPLACEMENT
 PART INFORMATION

- CUT WOOD AND CARPET TO FIT (SP56-079)

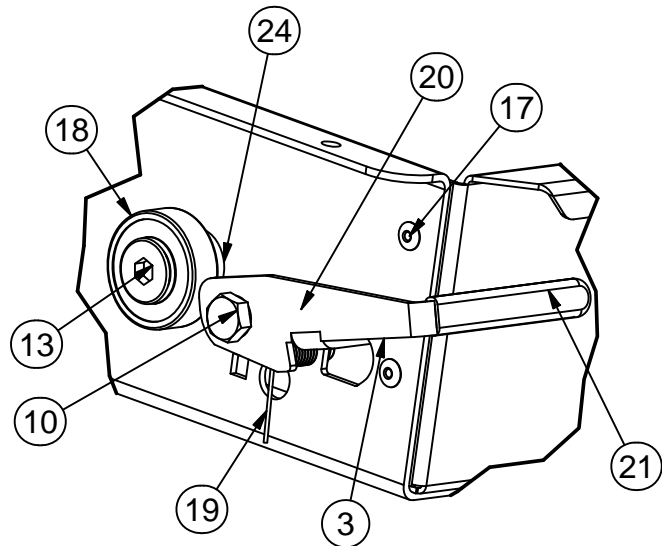
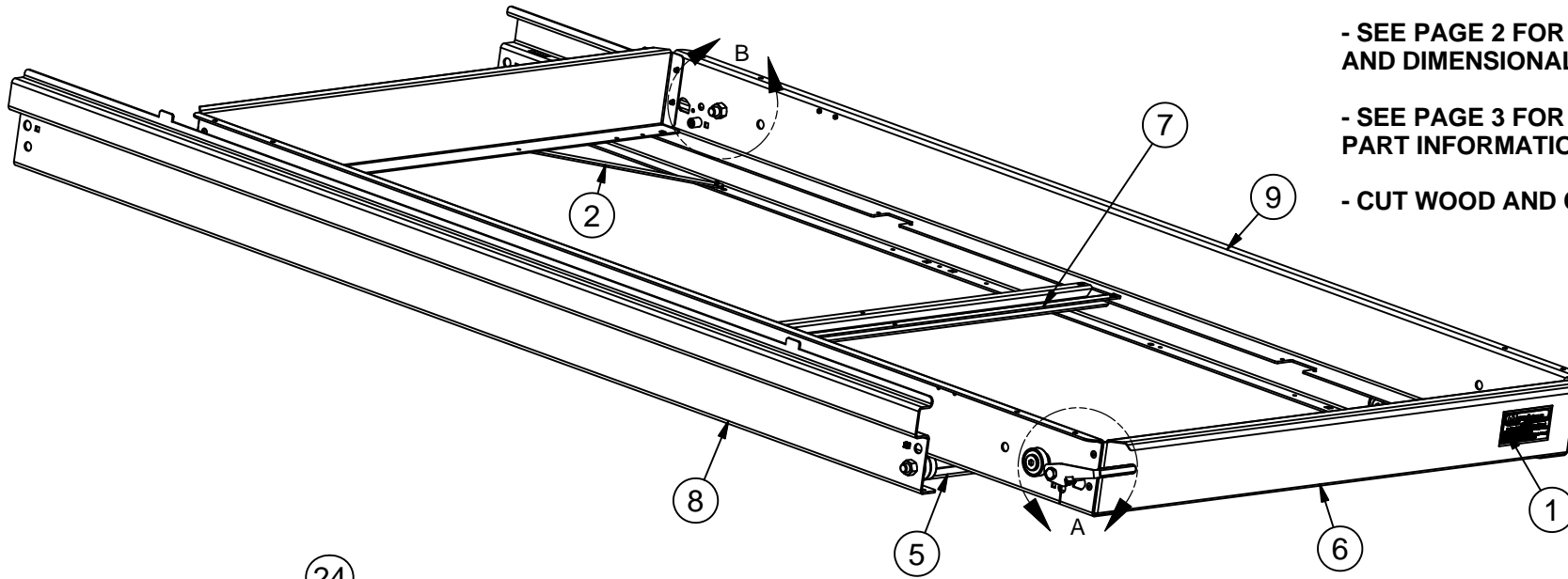

DETAIL A

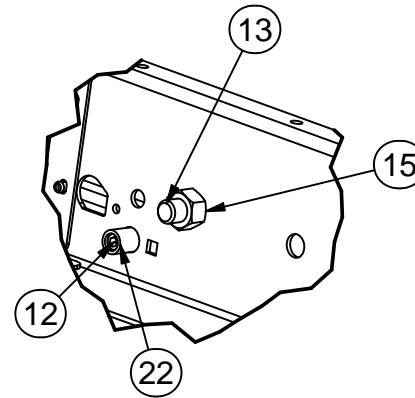

DETAIL B

Parts List		
ITEM	QTY	PART NUMBER
1	1	CARGO TRAY STICKER
2	2	CTG205-001
3	1	CTG213-001
4	1	CTG213-058
5	2	CTG224-Width
6	2	CTG225-Width
7	1	CTG226-Width
8	2	CTG227-072
9	2	CTG228-072
10	1	UO115-013
11	1	UO115-298
12	2	UO115-359
13	6	UO115-372
14	1	UO116-002
15	6	UO116-094
16	1	UO116-105
17	26	UO136-137
18	8	UO136-441
19	1	UO136-486R
20	1	UO136-488
21	1	UO136-496
22	2	UO136-605
23	2	UO136-638
24	4	UO136-707
25	2	UO136-758

DRAWN: Jon Kauffman	CHECKED: DATE: 8/2/2011
MATERIAL: STEEL	
FINISH: SEE NOTE	
ALL DIMENSIONS ARE O.D. UNLESS OTHERWISE NOTED TOLERANCE OF DIMENSIONS (INCHES) UNLESS OTHERWISE SPECIFIED:	
LASER:	2 PLACES ± 0.020 3 PLACES ± 0.010
BRAKE:	2 PLACES ± 0.063 3 PLACES ± 0.031
WELDING:	2 PLACES ± 0.063 3 PLACES ± 0.031
SHOP ENG:	2 PLACES ± 0.030 3 PLACES ± 0.010
CUTOFF:	± 0.031
ANGULAR:	± 1°
FLATNESS:	± 06/10.00

CTG60-XX72

CARGO SLIDE XX" x 72"



THIS DRAWING & THE INFORMATION CONTAINED THEREON ARE
 THE EXCLUSIVE PROPERTY OF MORRYDE. THEY SHALL NOT
 BE COPIED OR DUPLICATED WITHOUT OUR CONSENT.

Table			
Part Number	Dim. "A"	Dim. "B"	# OF HAT CHANNELS
CTG60-2072W	19.74	16.85	1
CTG60-2672W	25.74	22.85	1
CTG60-2972W	28.74	25.85	1
CTG60-3372W	32.74	29.85	1
CTG60-3672W	35.74	32.85	1
CTG60-3972W	38.74	35.85	1
CTG60-4272W	41.74	38.85	2
CTG60-4872W	47.74	44.85	2
CTG60-5272W	51.74	2	

- CT - POWDER COAT BLACK
- CTG - POWDER COAT GRAY
- CUT WOOD AND CARPET TO FIT (SP56-079)

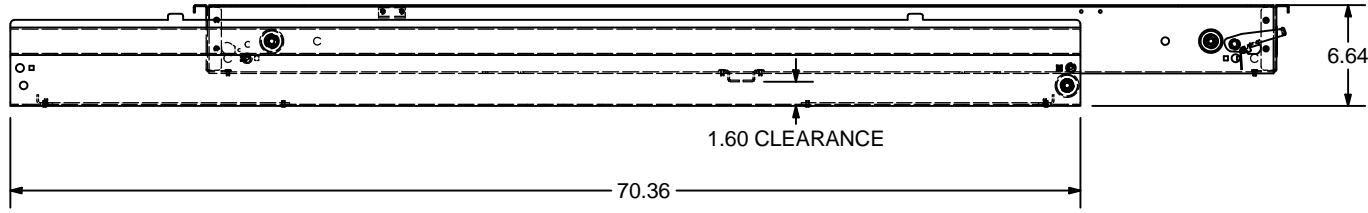
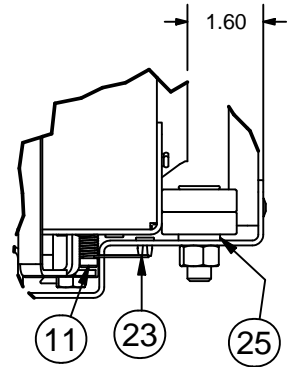
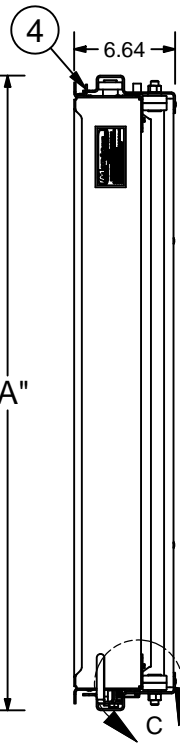
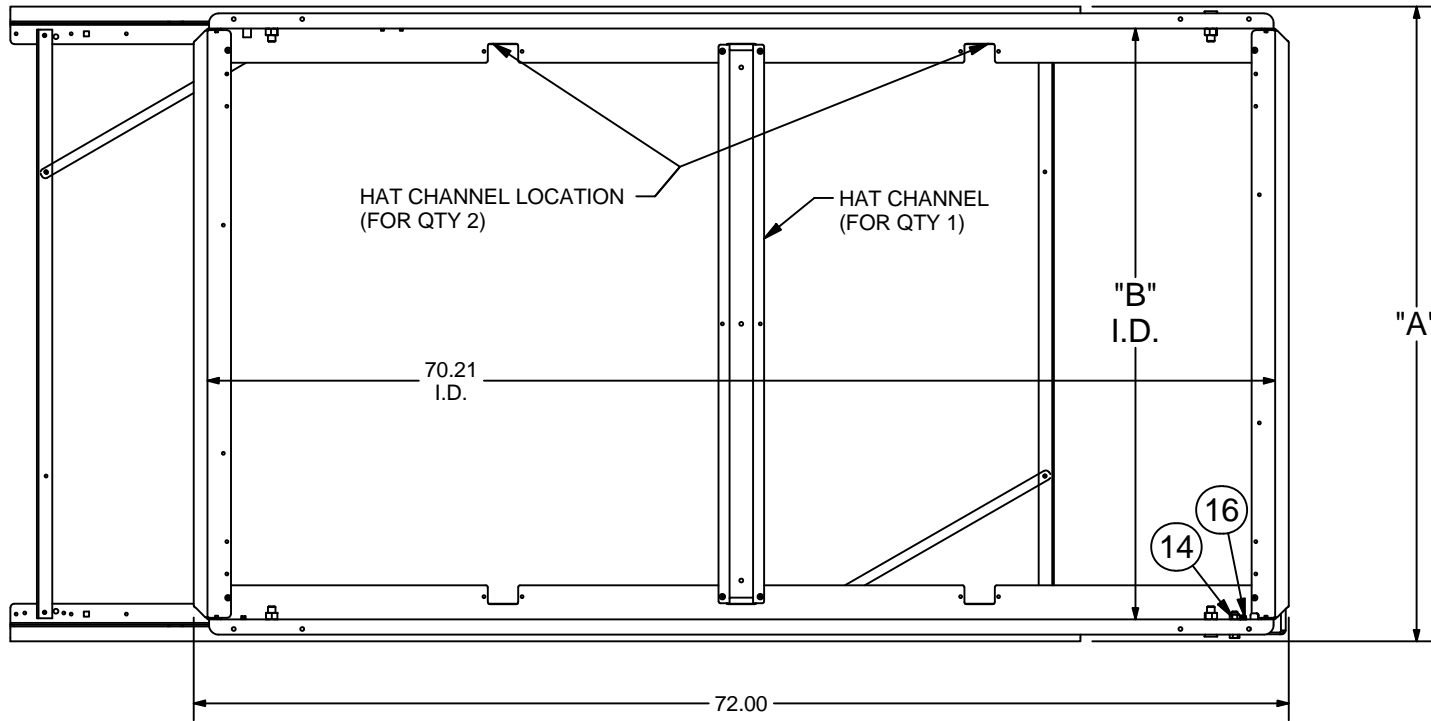

DRAWN: Jon Kauffman MATERIAL: STEEL FINISH: SEE NOTE ALL DIMENSIONS ARE O.D. UNLESS OTHERWISE NOTED TOLERANCE OF DIMENSIONS (INCHES) UNLESS OTHERWISE SPECIFIED: LASER: 2 PLACES ± 0.020 3 PLACES ± 0.010 BRAKE: 2 PLACES ± 0.063 3 PLACES ± 0.031 WELDING: 2 PLACES ± 0.063 3 PLACES ± 0.031 SHOP ENG: 2 PLACES ± 0.030 3 PLACES ± 0.010 CUTOFF: ± 0.031 ANGULAR: ± 1° FLATNESS: ± 0.6/10.00	CHECKED: 8/2/2011 DATE: CTG60-XX72 CARGO SLIDE XX" x 72"  <small>Elkhart, Indiana</small> THIS DRAWING & THE INFORMATION CONTAINED THEREON ARE THE EXCLUSIVE PROPERTY OF MOR/RYDE. THEY SHALL NOT BE COPIED OR DUPLICATED WITHOUT OUR CONSENT.
SHEET 2 OF 3	

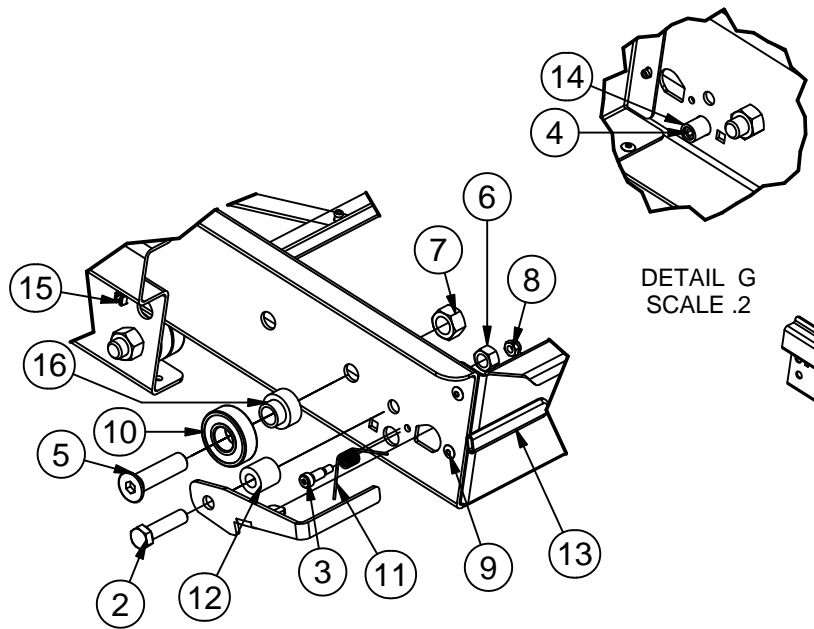

DETAIL F
SCALE .2

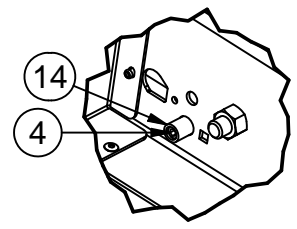

DETAIL G
SCALE .2

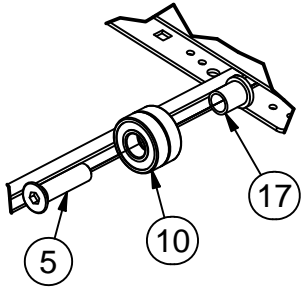
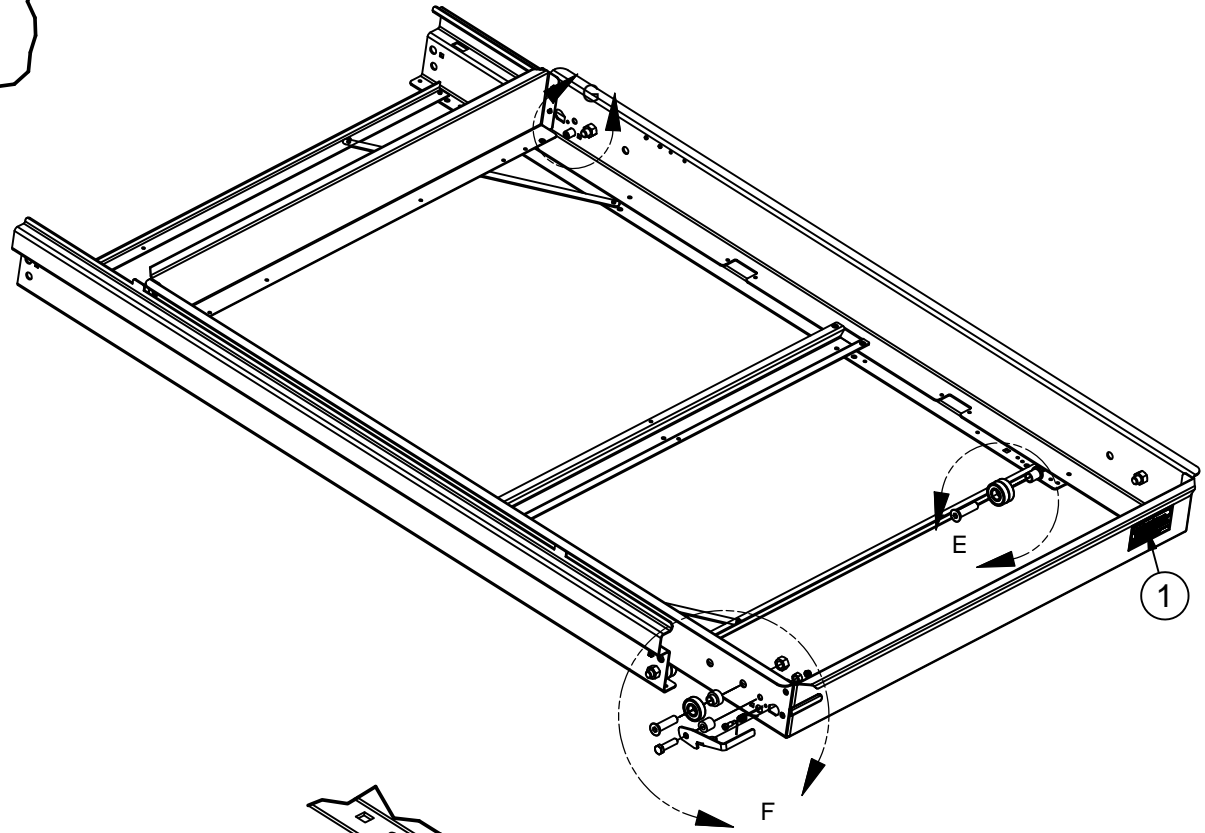

DETAIL E
SCALE .2

Parts List			
ITEM	QTY	PART NUMBER	DESCRIPTION
1	1	CARGO TRAY STICKER	
2	1	UO115-013	BOLT - 3/8-16 x 1-1/2" HHCS
3	1	UO115-298	BOLT - 10-24 SHOULDER OD x 1/4" x 1/2" LG
4	2	UO115-359	BOLT - 3/8-16 x 3/4" NYLON SET SCREW
5	6	UO115-372	BOLT - 1/2-13 x 2" FLAT HEAD SOCKET
6	1	UO116-002	NUT - 3/8-16 CENTER LOCK ZINC
7	6	UO116-094	NUT - 1/2-13 CENTER LOCK ZINC
8	1	UO116-105	NUT - 10-24 NYLON LOCK NUT
9	26	UO136-137	3/16 RIVET
10	8	UO136-441	BEARING - .668" ID x 1.575" OD x .47" WIDE
11	1	UO136-486R	TORSION SPRING 0.404 OD
12	1	UO136-488	PLASTIC SPACER - .38" ID x .75" OD .75" LG
13	1	UO136-496	YELLOW RUBBER GRIP
14	2	UO136-605	RIVET NUT - 3/8-16
15	2	UO136-638	NYLON GROMMET NUT, .060 HEAD HEIGHT
16	4	UO136-707	SINGLE BEARING SLEEVE - PLASTIC
17	2	UO136-758	DOUBLE BEARING SLEEVE - PLASTIC

DRAWN: Jon Kauffman	CHECKED: 8/2/2011	DATE:	CTG60-XX72 NONE
MATERIAL: STEEL			
FINISH: VARIOUS			CARGO SLIDE XX" x 72"
ALL DIMENSIONS ARE O.D. UNLESS OTHERWISE NOTED TOLERANCE OF DIMENSIONS (INCHES) UNLESS OTHERWISE SPECIFIED:			
LASER:	2 PLACES ± 0.020	3 PLACES ± 0.010	 <small>Elkhart, Indiana</small> THIS DRAWING & THE INFORMATION CONTAINED THEREON ARE THE EXCLUSIVE PROPERTY OF MOR/RYDE. THEY SHALL NOT BE COPIED OR DUPLICATED WITHOUT OUR CONSENT.
BRAKE:	2 PLACES ± 0.063	3 PLACES ± 0.031	
WELDING:	2 PLACES ± 0.063	3 PLACES ± 0.031	
SHOP ENG:	2 PLACES ± 0.030	3 PLACES ± 0.010	
CUTOFF:	± 0.031		
ANGULAR: ± 1°		FLATNESS: ± .06/10.00	
			SHEET 3 OF 3