

# TRUE INDUCTION DOUBLE BURNER MINI DUO COOKTOP MANUAL

---



# TABLE OF CONTENTS

---

I.	Control Panel Overview.....	1
II.	Cooktop Installation.....	2-5
III.	Important safety Information.....	6-7
IV.	Product Specifications .....	7
V.	How to Use.....	8
	> Power Invariance Technology.....	8-9
	> Using the Temperature Setting.....	9
	> Using the Timer Function.....	9
	> Built-In Safety Shut Off.....	10
	> Turning Off Unit .....	10
VI.	Compatible Cookware .....	10
VII.	Cleaning & Maintenance .....	11
VIII.	Troubleshooting Error Codes .....	11-12

Thank you for purchasing the **True Induction Double Burner Mini Duo cooktop**. Please read the entire instruction manual prior to using your unit. If you have any questions regarding the True Induction cooktop please visit <http://www.TrueInduction.com> or call: **1-877-862-7049**.



# I. Control Panel Overview

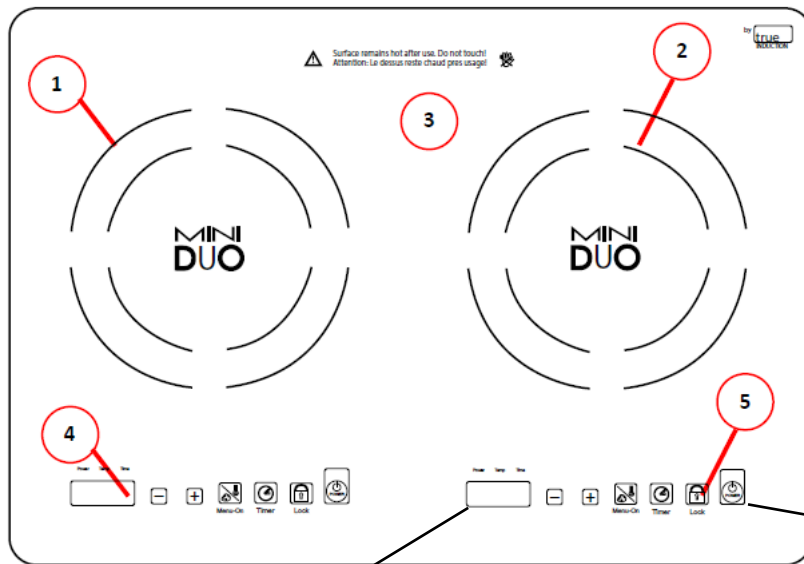

1. Left Cooking Zone
2. Right Cooking Zone
3. Ceramic- Glass
4. Left Touch Control Panel
5. Right Touch Control Panel
6. Power Option Display
7. Lower Power Key
8. Raise Power Key
9. Cooking Zone ON/OFF Key
10. Time Control Key
11. Child Safety Lock
12. Power Button

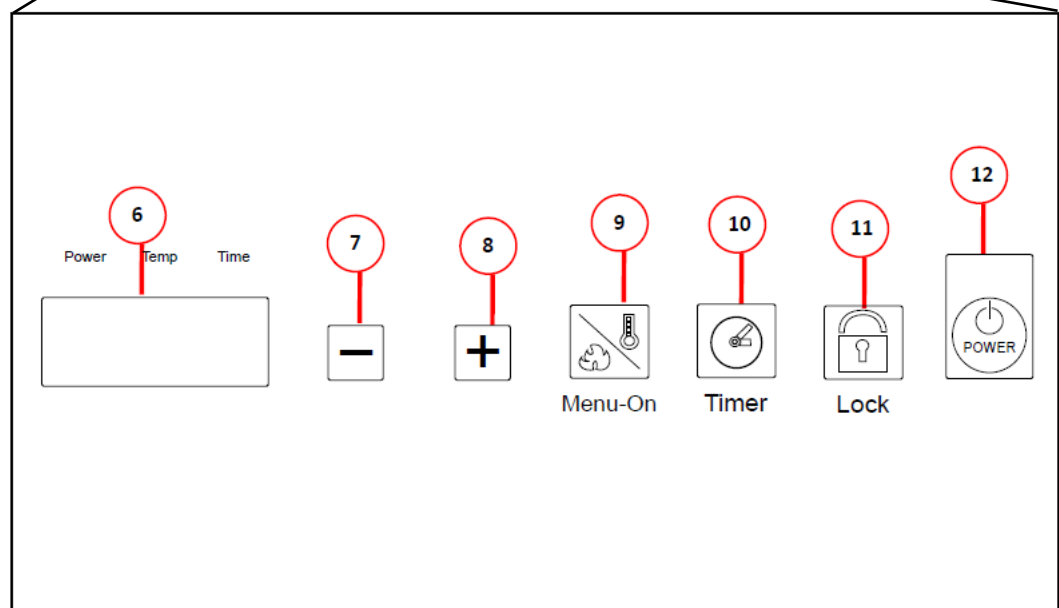

## II. Cooktop Installation

### Portable Installation

---

#### For Portable Unit Install

- To use the Mini Duo as a portable unit, locate the 4 feet in the packaging and screw them into the bottom as illustrated below.

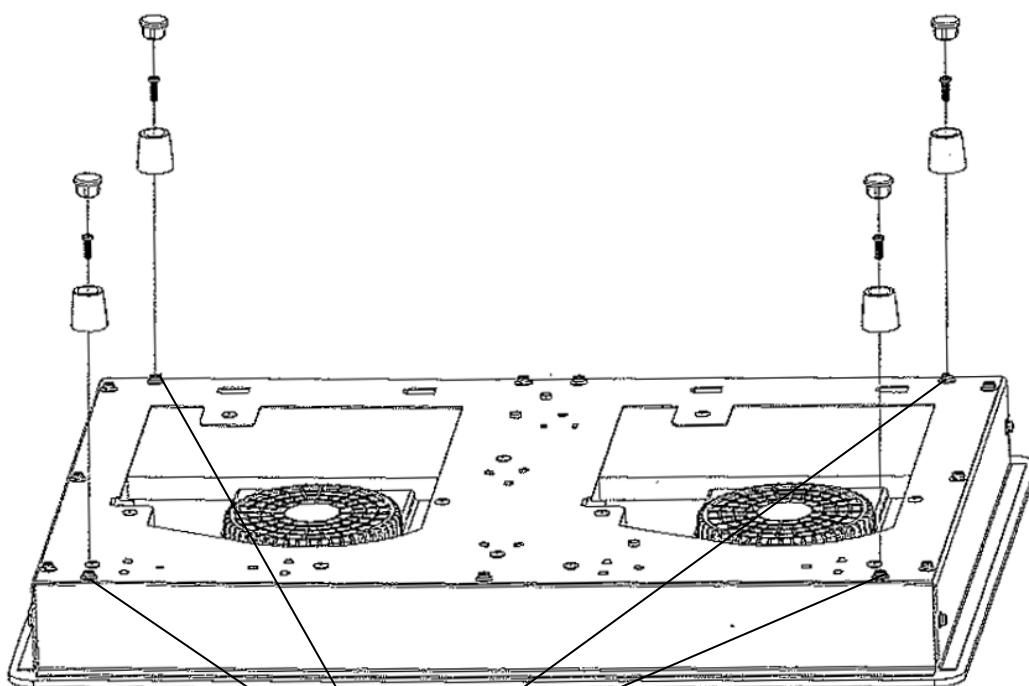

\*Take out screw before installing

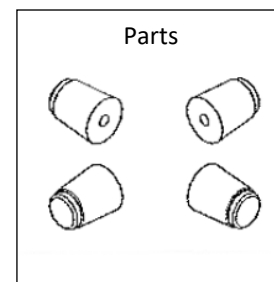

## II. Cooktop Installation Continued...

### Dimensions and Placement for Cut-out in Countertop

This appliance is not user serviceable. Installation must be completed by a qualified technician.

#### WARNING!

**FOR YOUR SAFETY:** Do not store or use gasoline or other flammable vapors and liquids in the vicinity of the unit. To eliminate the risk of burns or fire due to overheating, cabinets located above the induction cooktop should be avoided or allowed a minimum of 30" clearance. If cabinet space is available, the risk can be reduced by installing a range hood at a minimum of 5 inches below the bottom of the cabinets.

#### IMPORTANT INSTALLATION INFORMATION:

All electric cooktops run off of a single phase, three-wire cable, 120V/60Hz AC only electrical supply with ground. The installation should be made using wires, conduits, and fittings size in accordance with the National Electrical Code- ANSI/NFPA 70.

- Cut a rectangle hole in the countertop where the cook top is to be placed. The dimensions for the cut-out are 13 3/4" x 20"
- The cut-out must be placed at least 2 1/2" from any side of the countertop.
- To achieve flush mounting installation, use a router tool to round the corners of the hole cut into the countertop.

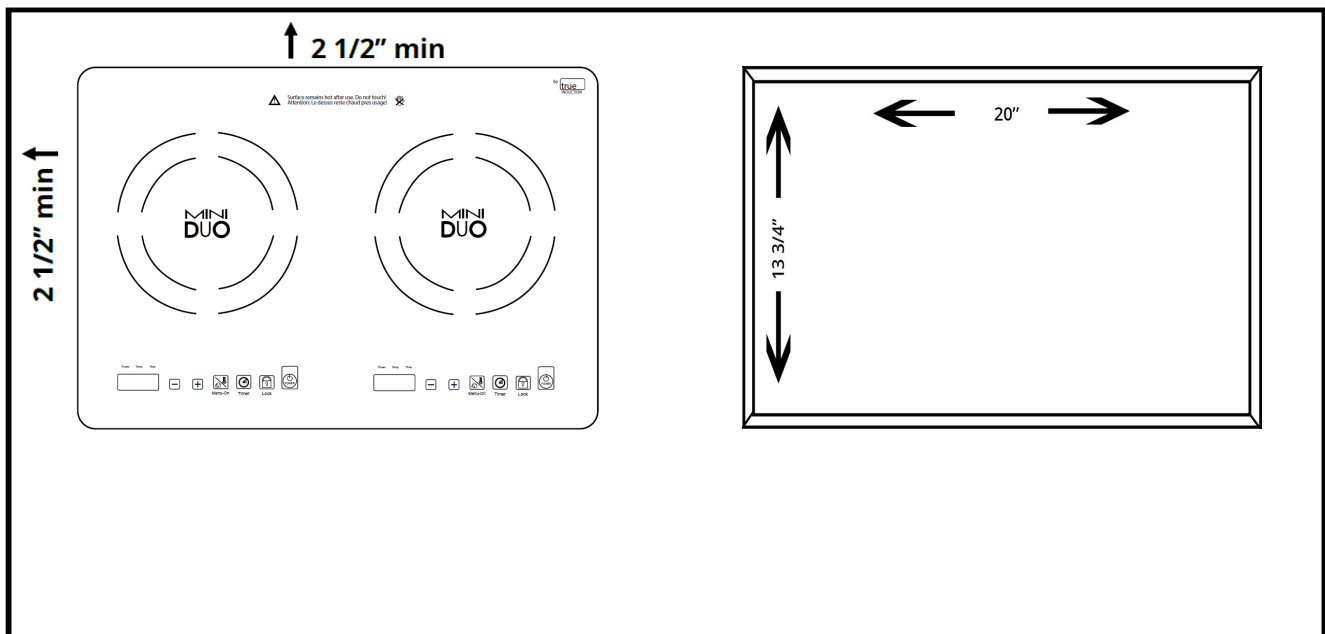

## II. Cooktop Installation Continued...

---

- First feed the power wire through the hole and to the location of the power receptacle underneath the cabinet.
- The 'h' overhang on the induction cooker comes with pre-installed foam gasket. Peel off the adhesive protector on the bottom of the gasket and set the induction cooker into the cut-out. Gently press down on the induction cook top to secure the adhesive gasket to the countertop. The cook top should be sitting on the supports previously installed.
- For RV use, apply butyl tape instead of the supplied foam tape. Butyl tape will provide adequate adhesion and still allow for removal if the unit needs to be serviced.

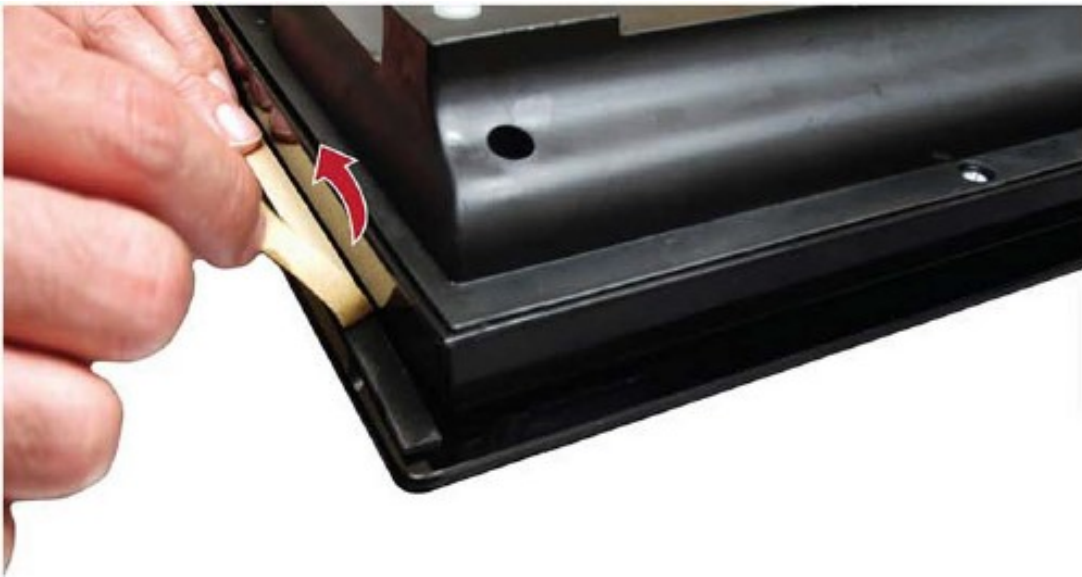

## II. Cooktop Installation Continued...

### Clearance Needed for Air Circulation

---

- Below you will see a diagram of the air flow. Be sure not to block either the intake or exhaust

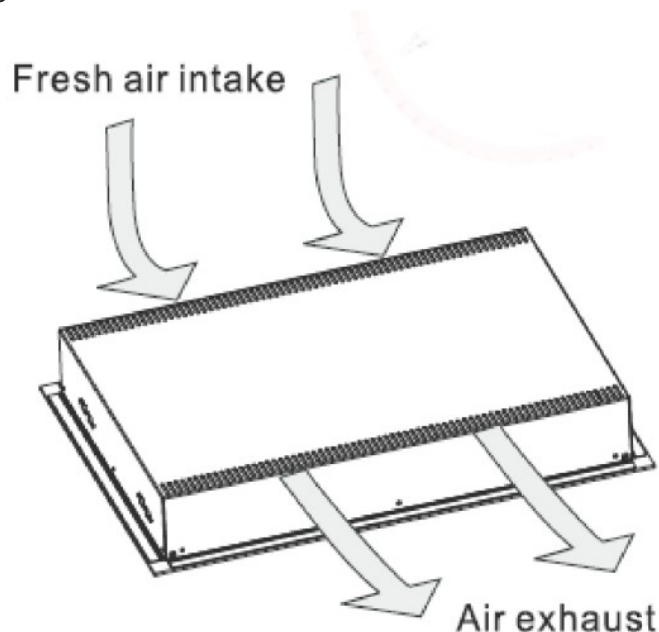

- For proper air circulation, allow at least 3" of clearance from the bottom of the induction cooker to any shelving or storage. The underside of the countertop should not be closed off from the cabinetry underneath for better air flow.

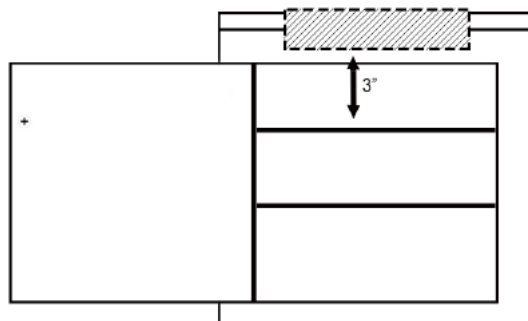

### III. Important Safety Information

---

When using electrical appliances, basic safety precautions should always be followed. For the True Induction cooker, even with built-in safety features, it is essential to heed all precautions:

- When the unit is on, do not touch outside the control panel as the surface may contain residual heat.
- To protect against electric shock, do not immerse cord plugs or cooker in water (or other liquid substances).
- When using any electric appliance used around children, close supervision is strongly suggested.
- Do not operate any appliance with a damaged cord or plug, after a malfunction or if it has been damaged in any manner. Read the seller's guidelines for warranty repairs and returns.
- Do not cook on a broken or damaged cooktop as spillovers may penetrate the surface and create a risk of electric shock.
- To avoid potential injury, do not use accessory attachments which aren't recommended by the manufacturer.
- Do not let the cord dangle over the edge of the table or counter. Keep the cord away from hot surfaces.
- Do not place cooktop on or near: hot gas, electric burner or heated oven.
- To prevent accidents and achieve optimal fan ventilation, allow for sufficient space around the cooking area.
- Items with a magnetic field such as: radios, televisions, credit cards, cassette tapes etc., can affect the unit.
- The power cord provided has been sized accordingly, however, with caution and care extension cords may be used.
  - a. The marked electrical rating should be at least as great as the electrical rating of the appliance.
  - b. The cord should be arranged so that it will not drape over the countertop or tabletop where it can be pulled on by children or tripped over.
- Do not use with empty pans/pots.
- Do not place metallic objects such as knives, forks, spoons, lids, cans or aluminum foil on the cooktop.
- To prevent accidents and achieve optimal ventilation, allow for sufficient space around the cooking area.





### III. Important Safety Information Continued...

---

- This appliance has a polarize plug (one blade is wider than the other). To reduce the risk of electric shock, the plug will fit on the outlet only one way. If the prongs do not fit fully, reverse the plug. If it still does not fit, contact the seller for warranty support; do not attempt to modify the plug in anyway.
- To properly turn off unit press the Power button.
- It is important to be aware that the unit's surface will remain hot for a short period of time after use.
- Disconnect power and allow to cool before performing any maintenance or repairs.
- Clean cooktop with caution - do not clean while unit is still hot, some cleaners produce steam or fumes if applied to a heated surface.
- Do not use cooktop for any other use then directed by the manufacturer.

### IV. Product Specifications

---

<b>Power</b>	1800 Watts
<b>Voltage</b>	110v/ 60Hz
<b>Temperature Range</b>	150°F - 450°F (in 10 degree variables)
<b>Level Selection</b>	Selecting settings 1—10
<b>Max Time</b>	Set timer up to 150 minutes
<b>Material</b>	Glass ceramic top
<b>Unit Measurement</b>	20 1/2" W x 14 "L x 2 " H



## V. How to Use

---

- Plug the power plug into a standard outlet.
- The Power button will light up and the unit will sound to indicate on.
- The device will remain in standby mode, awaiting user direction.
- Place ferromagnetic cookware (with water, oil or food already inside) on the center of the glass-ceramic top center.
- Now press the Power button on the control panel, this will turn the cooktop on. The power display will blink and sound another indicator.
- Press the Heat function key once. The pre-set power level "5" is the default selection as the device turns on.
- Using the +/- keys you can change the settings at any time, ranging from 1- 10. This is considered to be the HEAT function.

## Power Invariance Technology

---

The maximum power of an individual burner level is at setting 10. But, when operating both burners their combined total is level 10, meaning that when operating the two burners at the same time they'll self adjust levels accordingly:

- When you increase the power of one side, the power output of the other side will reduce automatically (i.e., one side is at 6, the other burner automatically reduces power to level 4 creating a total of max 10 setting).
- If one side of the double burner is using the HEAT function and the other side uses the TEMP settings, the maximum HEAT setting is "5."



# V. How to Use Continued...

## Power Invariance Technology Continued...

---

Level	1	2	3	4	5	6	7	8	9	10
Rated power										
Right 1800W	100W (500W on for 2 sec. off for 8 sec.)	300W (500W on for 6 sec. off for 4 sec.)	500W	700W	900W	1100W	1300W	1500W	1700W	1800W
Left 1800W	100W (500W on for 2 sec. off for 8 sec.)	300W (500W on for 6 sec. off for 4 sec.)	500W	700W	900W	1100W	1300W	1500W	1700W	1800W

NOTE: This function is equipped with safeguards against parching. The unit might shut off automatically when this function is used for frying, stir-frying, grilling and other high temperature cooking formats.

## Using the Temperature Setting

---

Using the +/- keys you can change the temperature settings at any time. Settings range from 150-450 degrees Fahrenheit. (Exact temperatures: 120, 150, 180, 210, 260, 300, 360, 420 and 460 F).

## Using the Timer Function

---

- After selecting the HEAT or TEMP mode, press the TIMER button once. The display will show the number "0." Using the +/- keys you can select the operating time in 5-minute intervals (up to max 150 min.) and reducing 1 minute.
- The display will count down the duration in minutes. Once the time is up, the unit sounds and automatically goes into standby mode. To continue cooking, press the Power button and Heat button to restart.
- During the timer operation, you can change the timer duration at any time with the arrow keys. The device's built-in memory maintains the HEAT or TEMP setting previously entered.
- You can also change the HEAT or TEMP settings without affecting the current timer setting.



## V. How to Use Continued...

### Built-In Safety Shut Off

---

- The True Induction cooktop is designed to automatically shut off after 150 minutes of use. This built-in auto shut off is a safety feature.
- This function occurs for both the HEAT and TEMP settings. The panel displays EE code and sounds indicating this auto-off setting.
- In the event your food requires further cooking, the unit can easily be turned back on and re-set to the desired setting

### Turning Off Unit

---

- When you are finished cooking, simply press the Power button to turn off the machine.
- Upon completion of cooking, the fan may remain on until the unit is cool.

## VI. Compatible Cookware

---

Induction requires pots and pans that are made of ferrous (meaning magnetic) materials. Check your cookware's retail box for the induction symbol. To tell if your current cookware is compatible with the induction technology, grab a magnet and see if it holds. If your magnet stays then your cookware is ready to be used on the True Induction double burner induction portable cooktop!

Optimal cookware has a flat bottom and a diameter of 4.5" - 10" inches. Round, flat bottom pans give the best results. Pans with warped or curved bottoms will not heat evenly. For wok cooking, use a flat-bottom wok. Do not use a wok with a support ring. Look for this induction image on the retail box:

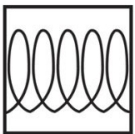

Induction

### The following are NOT COMPATIBLE:

- Heat-resistant glass, ceramic, copper, aluminum pan/pots, round bottomed cookware, or cookware with a base less than 4.5 inches.



## VII. Cleaning & Maintenance

---

Please follow these directions along with important safety steps for cleaning advised at the beginning of the manual:

- Before cleaning always switch OFF the device and wait for it to be completely cool. Clean the unit after each use to remove food residues.
- Wipe off the glass-ceramic plate and the plastic surface with a slightly damp cloth (micro-fiber works best). Dishwashing soap may be used when necessary.
- Make sure that no water seeps into the device. **Never use abrasive cleaners (i.e. metal pads) or oil-based liquids. Never run the cooktop under water.**
- A vacuum cleaner attachment may be used to suck up dirt from the air intake and exhaust vent.

## VII. Trouble Shooting Error Codes

---

If the display shows an error code, please reference this sheet for a potential solution:

Error Code	Cause and Potential Solution
Cooktop does not work	Make sure Lock mode is turned off. Check house lights to confirm power outage.
Cooktop will not heat up	Make sure that the cookware is induction cookware compatible. See <b>Section VI Compatible Cookware.</b>
Cooktop turns off while cooking	<ul style="list-style-type: none"><li>• Make sure that the cooktop vents are not blocked.</li><li>• The cooktop features an automatic shut off function that will turn off the cooktop if the cooktop has been powered on for 2 hours and left idle.</li><li>• The cooktop control panel may detect liquids or objects obstructing the panel, which causes the cooktop to shut off. Check for spills or remove objects, and restart the unit.</li></ul>
The fan keeps running for one minute after the unit has been switched off	This is a normal occurrence as the electronics are cooling down.



## VII. Troubleshooting Error Codes Continued...

If the display shows an error code, please reference this sheet for a potential solution:

Error Code	Possible Cause	Solutions
<b>Power Sharing</b>	When two heating zones are turned on, will create a total max 10 setting	See <b>POWER SHARING</b>
<b>E0</b>	IGBT (Insulated Gate Bipolar Transistor) overheating	Turn off unit to allow IGBT to cool. Restart unit.
<b>E1</b>	No cookware found or improper placement of cookware on the cooking zone	Make sure that the cookware is centered on the cooking zone, and that it is also induction compatible. See <b>COMPATIBLE COOKWARE</b>
<b>E2</b>	Supplied voltage to cooktop is too low	If the voltage of the power supplied to the cooktop is too low, it cannot operate properly and will show this error code. This may be caused by reduced voltage being supplied to the house circuit. If connections are correct and the supplied voltage returns to normal, the code will disappear.
<b>E3</b>	Supplied voltage to cooktop is too high	If the voltage of the power supplied to the cooktop is too high, it cannot operate properly and will show this error code. This may be caused by increased voltage being supplied to the house circuit. If the connections are correct and the supplied voltage returns to normal, the code will disappear.
<b>E7</b>	NTC1 (To check the temperature of IGBT) break off	Turn OFF the cooktop: then shut off the power at the fuse or circuit breaker for about 30 seconds. Turn the power back on to the cooktop then press the POWER button to turn on the unit. If the error message is still being displayed, call for service.
<b>E8</b>	NTC1 ( To check the temperature of IGBT) short circuit	
<b>E9</b>	NTC2 (To check the temperature of heating center) Break off	
<b>EE</b>	NTC2 (To check the temperature of heating center) short circuit	

