



REFLEX STEERING STABILIZER **KIT# RBK6**

INSTALLATION INSTRUCTIONS

85-4124-06
05-18

ROADMASTER, Inc. 6110 NE 127th Ave. Vancouver, WA 98682 360-896-0407 fax 360-735-9300 www.roadmasterinc.com

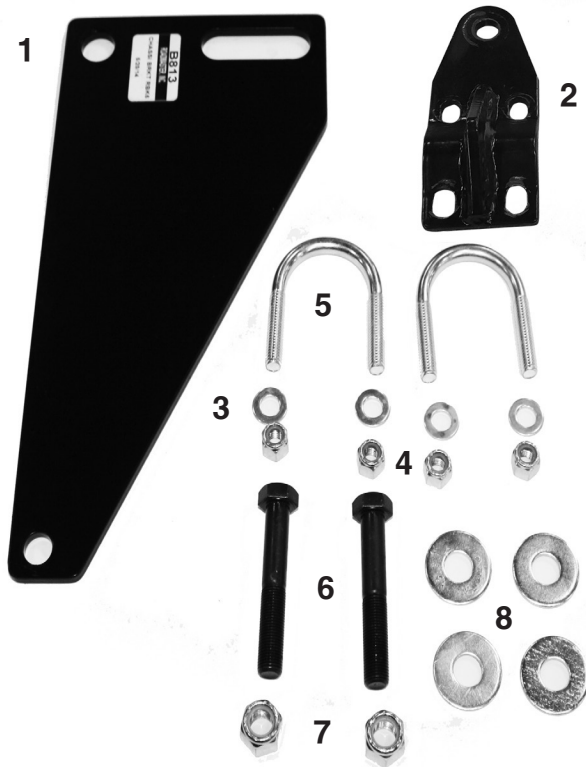

Part #	Description	Qty
1. B813	Chassis Bracket	1
2. B802	Tie Rod Bracket	1
3. 355710-00	10mm Flat Washers	4
4. 350255-00	3/8" Lock Nuts	4
5. LRG38	3/8" U-bolts	2
6. 350101-50	1/2" x 3" Hex Bolts	2
7. 350259-01	1/2" Lock Nuts	2
8. 350308-00	1/2" Flat Washers	4

WARNING

Failure to follow these instructions can result in property damage, personal injury or even death.

- The installer must read the instructions and use all bolts and parts supplied. Failure to securely fasten the stabilizer could result in loss of the stabilizer, damage to the vehicle, personal injury or even death.
- There must be adequate clearance between the Reflex Steering Stabilizer and all chassis and steering parts, and any other components, or non-warranty damage to the vehicle will result. After final installation, the installer must inspect the stabilizer to ensure adequate clearance. Some minor adjustments may be needed to achieve this; always verify that the steering wheel remains centered before and after these adjustments.
- Always test drive the vehicle to confirm the steering wheel settings. If the vehicle pulls to either side, the center positioning must be adjusted. If the steering wheel does not return to the center position, the tie rod bracket may require minor adjustments. Failure to adjust the center positioning may result in a loss of vehicular control.
- After installing the Reflex Steering Stabilizer, any technician performing alignment or suspension work on the motorhome must loosen the tie-rod bracket to adjust the toe; the technician must also re-adjust the steering damper. Failure to adjust the center positioning may result in a loss of vehicular control.
- Regardless of year, make and model, a wide range of options for specific applications may or may not interfere with the installation. It is the

installer's responsibility to make certain that equipment is not damaged once the suspension solution travels through the full range of motion. Failure to ensure adequate clearance could result in non-warranty property damage, personal injury or even death.

- If running changes were made by the vehicle manufacturer after this kit was designed, some bolts or other fasteners in the included hardware pack may no longer be the correct size. It is the installer's responsibility to verify that the stabilizer is securely fastened to the vehicle, and fitted with the correct hardware, to account for these changes. Failure to securely fasten the stabilizer could result in loss of the stabilizer, damage to the vehicle, personal injury or even death.
- Except to adjust for running changes to the vehicle, use only the parts supplied by ROADMASTER to install the stabilizer. Using substandard grade parts or parts of the wrong size may result in loss of the stabilizer, damage to the vehicle, personal injury or even death.
- Once a year, the owner must inspect the fasteners for proper tightness and/or torque, according to the bolt torque requirements chart in these instructions. Failure to securely fasten the stabilizer could result in loss of the stabilizer, damage to the vehicle, personal injury or even death.
- Do not use an air impact wrench when reinstalling bolts, as stripped threads may result.
- This stabilizer is only warranted for the original installation. Installing a used stabilizer on another vehicle is not recommended and will void the warranty.



REFLEX STEERING STABILIZER KIT# RBK6

INSTALLATION INSTRUCTIONS

85-4124-06
05-18

ROADMASTER, Inc. 6110 NE 127th Ave. Vancouver, WA 98682 360-896-0407 fax 360-735-9300 www.roadmasterinc.com

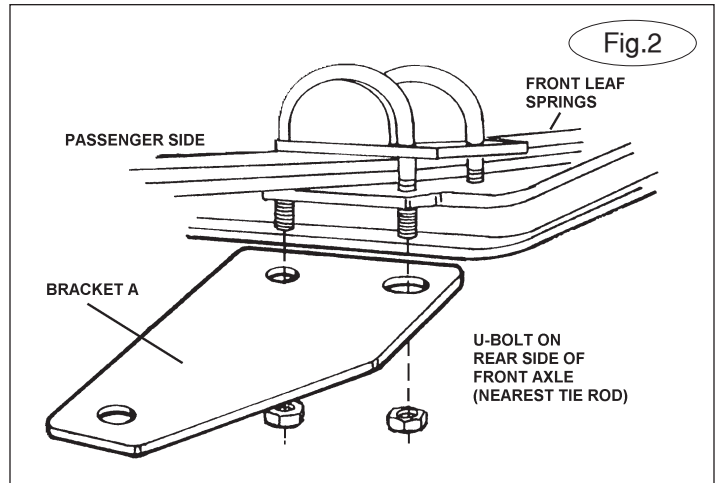

Note: Before installing the shock component of this system, please ensure that the spring is fully-seated in its track on the collar of the unit. If it is installed without the spring fully-seated in its track, the unit could malfunction or otherwise fail to operate properly (Fig.1).

1. *Note:* due to manufacturing variances, the vehicle may be equipped with either an air or leaf spring suspension system. On the passenger side, remove the nuts from the U-bolts on the **rear side** of the front axle nearest to the tie rod (Fig.2).
2. Place the chassis bracket over the front axle U-bolts with the slotted hole facing the passenger side of the vehicle (Fig.2). Replace the factory nuts and torque them to the manufacturer's recommendations.

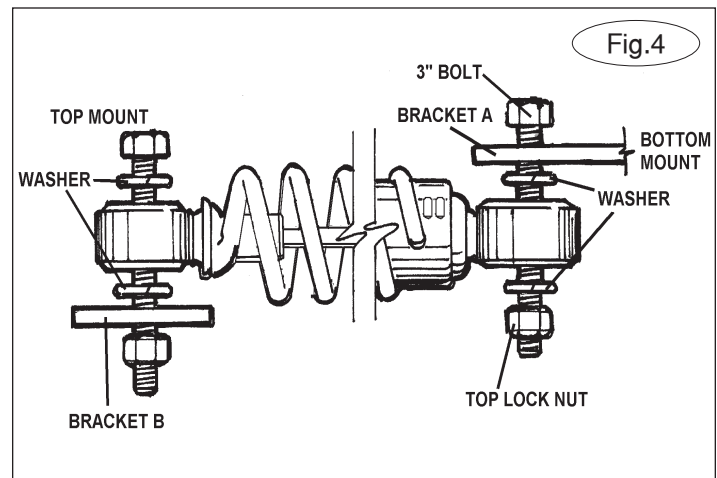
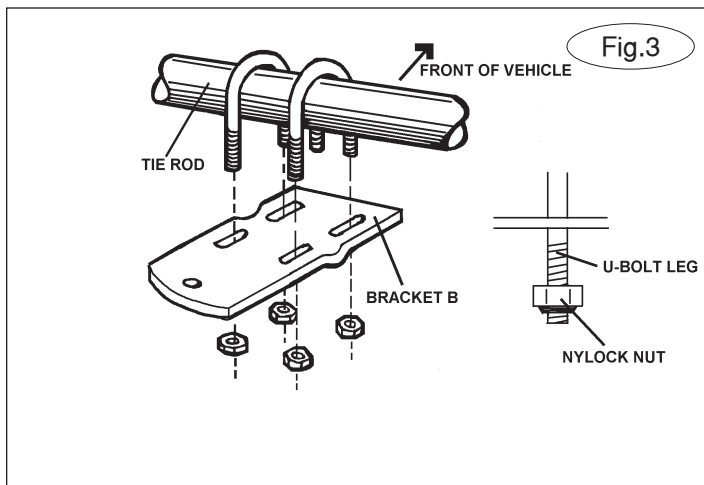

3. On the driver's side, install the Reflex tie rod bracket to the underside of the tie rod with the 1/2" bolt hole facing toward the rear of the vehicle (Fig.3). Place the two supplied 3/8" U-bolts over the top of the tie rod, and insert them through the corresponding tie rod bracket holes. Place the four provided 3/8" lock nuts and 10mm flat washers over each U-bolt (Fig.4). Finger-tighten them only at this time so the bracket may be positioned along the tie rod later in the installation process.
4. Place one 1/2" x 3" bolt through the underside of the chassis bracket (Fig.4). Place one of the provided 1/2" flat washers and the Reflex stabilizer loop mount over the end of the bolt. Place another 1/2" flat washer over the bolt to rest on the loop mount, and one of the provided 1/2" lock nuts over the bolt. Finger-tighten only at this time.



REFLEX STEERING STABILIZER **KIT# RBK6** INSTALLATION INSTRUCTIONS

85-4124-06
05-18

ROADMASTER, Inc. 6110 NE 127th Ave. Vancouver, WA 98682 360-896-0407 fax 360-735-9300 www.roadmasterinc.com

5. With the front wheels pointing straight ahead, attach the Reflex stabilizer piston rod loop mount on the top side of the tie rod bracket (Fig.4), repeating step 4 assembly instructions.

6. Tighten the 1/2" and 3/8" lock nuts. Torque the hardware to approximately 30 ft./lbs.

7. Test drive the vehicle to make certain that the Reflex stabilizer is adjusted properly. If the steering pulls to either side, center it by loosening the bracket U-bolts at the tie rod, and then reposition it. Tighten the bolts and test drive it once again, repeating the process until the proper adjustment is achieved.

BOLT TORQUE REQUIREMENTS

STANDARD BOLTS			U-BOLTS	
Thread	Grade	Torque	Thread	Torque
3/8.....	5.....	30 ft./lbs.	3/8-24	35 ft./lbs.
7/16.....	5.....	50 ft./lbs.	1/2-20	70 ft./lbs.
1/2.....	5.....	75 ft./lbs.	5/8-18	140 ft./lbs.
5/8.....	5.....	140 ft./lbs.	3/4-16	250 ft./lbs.
			7/8-14	400 ft./lbs.

Note: Endlink bolts use grommets and should NOT be torqued. Tighten these bolts by hand until the grommet starts to deform. Also, these torque values are intended as general guidelines. Roadmaster does not warrant this information to be accurate for all applications and disclaims all liability for any claims or damages which may result from its use.