



Installation Instructions

Rear Trac Bar - Part# SS400

This product is designed to eliminate side shift of the rear axle on a 14,000-18,000 GVW Ford F-53 chassis. (Dana 80 differential with bolt-on rear inspection cover)

Installation time is 1-2 hour

A qualified mechanic using normal automotive tools and following all safety measures known, should perform installation of this product.

SS400 TRAC BAR PARTS LAYOUT

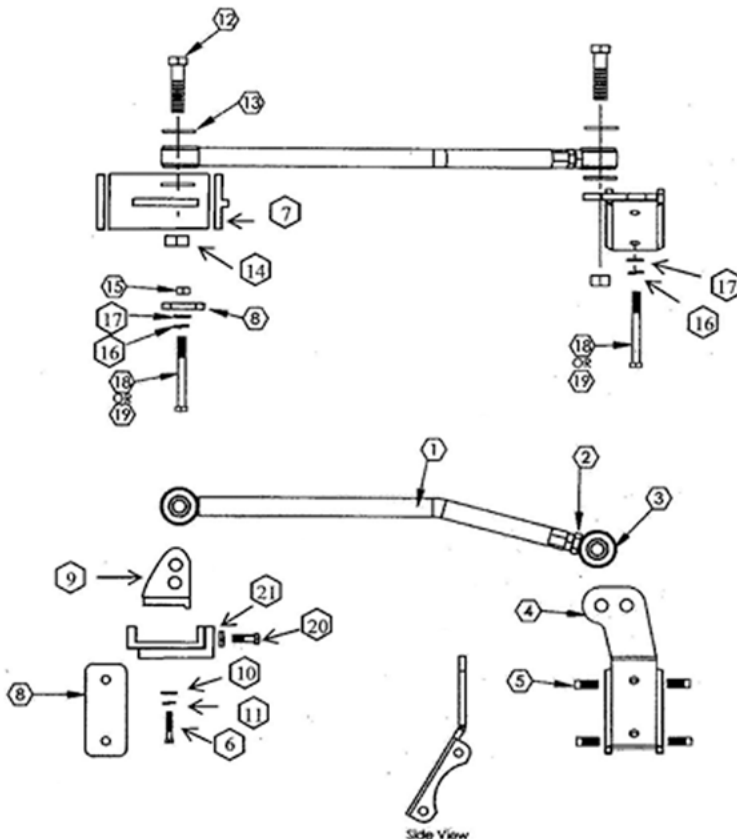

ITEM #	DESCRIPTION	QTY
1	SS400-1 ROD ASSY	1
2	JAM NUT - 3/4 16UNF	1
3	ROD END ASSY	1
4	SS400-4 AXLE BRACKET ASSY	1
5	BOLT - 1/2X1 13UNC SQUARE HEAD	4
6	BOLT - 5/8 X 1 3/4 NF	2
7	B754 FRAME BRACKET ASSY	1
8	SS400-5 SWAY BAR SPACER PLATE	1
9	B763 PINCH PLATE	1
10	5/8 FLAT WASHERS	2
11	5/8 LOCK WASHERS	2
12	BOLT - 3/4X3 16UNF	2
13	FLAT WASHER - 3/4	4
14	TOPLOCK NUT - 3/4 16UNF	2
15	NUT - 12MM	4
16	LOCK WASHER - 12MM	4
17	FLAT WASHER - 12MM	4
18	BOLT - 12MM X 120MM	4
19	BOLT - 12MM X 55MM	4
20	BOLT - 1/2 X 1 3/4 NF	2
21	JAM NUT - 1/2 NF	2

Item #	TORQUE SPEC. (FT. LBS)
2	100-150
5	SECURELY
6	70-80
10	70-80
12	120-150
18 or 19	45-55
20 and 21	SECURELY

Installation Instructions for Part # SS400 - Rear Trac Bar

A. Preparation

Move the coach to a level, flat surface. If necessary, drive the rear wheels of the coach onto 4" high blocks and set the brakes or you may drive the coach over a work pit and chock the front wheels. Block off adequate space at the rear of the coach to work.

B. Installation of the Axle Bracket

Remove and discard the 4 bolts, 2 on each side that hold the sway bar on the differential housing.

On the left hand side (Driver's side) insert the mounting bracket underneath the sway bar bracket and install bolts supplied in bolt kit. There are four holes drilled and tapped in the bracket to accept the four square head set-screws. Put a drop of lock tight on each set-screw and thread into the tapped holes. Tighten the set-screws down equally until they contact the bracket that is welded to the differential. This will stop the lateral movement of the bracket.

On the right hand side (passenger side) insert spacer plate (SS400-5) between sway bar brackets and differential. Install bolts supplied in kit.

Note: On earlier and lighter chassis the sway bar brackets are held on with 10mm bolts. We suggest that you remove the bolts and the nuts that are tacked on the differential and replace them with the 12mm bolts that are included in the kit. On some models, 12mm bolts are used. If 12mm bolts are used, replace them with the longer bolts that are included in the kit. Tighten to 45-55 ft. lbs.



**Looking back at
rear axle from
front of coach**

Installation Instructions for Part # SS400 - Rear Trac Bar

C. installation of the Frame Bracket

Install the frame bracket B-754 and pinch plate B-763 on the frame rail. The frame must be between the pinch plate and the frame bracket. The frame bracket is designed to mount to the bottom and sides of the frame rail. Position the frame bracket below the frame rail on the passenger side in line with the axle bracket.

Align slotted holes in frame bracket with threaded holes in pinch plate. (Place the pinch plate with lip facing down and towards center of vehicle). Install (2) 5/8"x1 3/4" fine threaded bolts, (2) 5/8" lock washers & (2) 5/8" flat washers. (Use blue Loctite and tighten "just snug" for now)

Note: Make sure not to contact any wires, brake lines, etc.

Use the Trac Bar to check alignment from axle plate to frame bracket. Adjust forward or back. Then install the jam nuts onto the 1/2" fine threaded bolts and install in the frame bracket. Tighten to push the pinch plate against the inside of the frame, then tighten the bottom bolts securely. Now tighten the jam nuts against the bracket to lock the 1/2" fine threaded bolts into place and keep it from backing out.

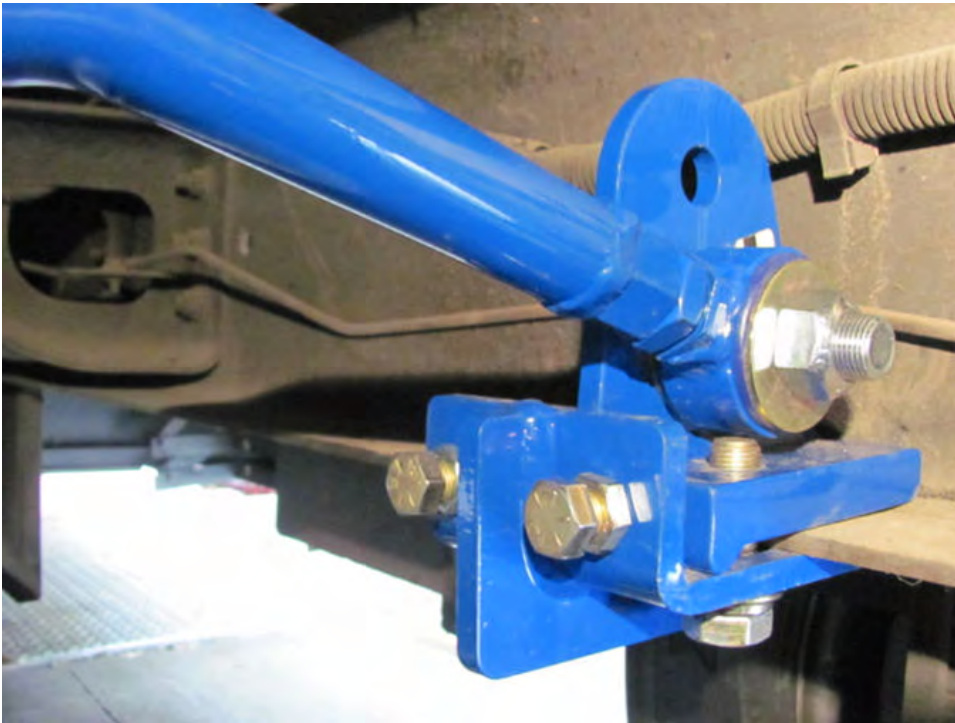

**Looking at passenger
side frame rail from
rear of coach
(towards front)**

D. Installation of Rod Assembly

Install the rod assembly using the 3/4" bolts, flat washers and lock nuts. Be sure that there is a flat washer on each side of the urethane bushings. When adjusting the length of the rod assembly it is necessary that the coach's full weight be on the suspension.

Mount bar behind frame bracket and in front of axle bracket and adjust to fit with coach at NORMAL RIDE HEIGHT (FULL WEIGHT OF THE COACH ON THE TIRES). Torque large bolts to 120-150 ft. lbs, then torque jam nut to 100 to 150 ft. lbs.

Installation Instructions for Part # SS400 - Rear Trac Bar

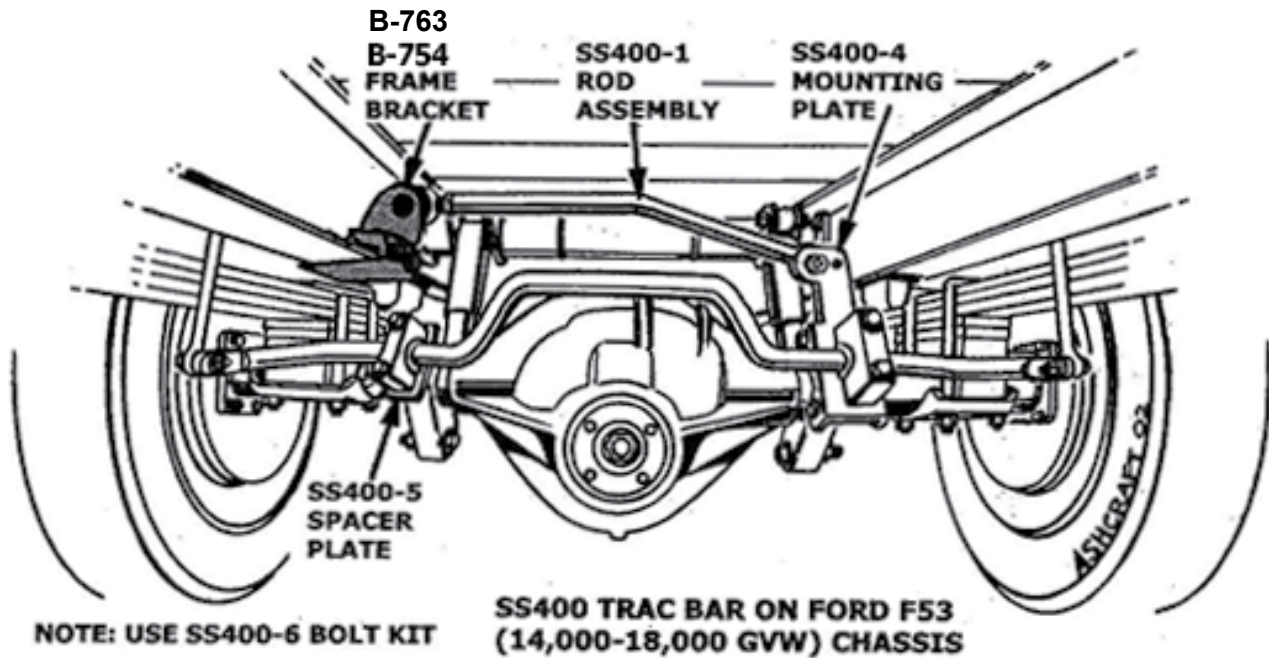

E. Torque Specifications & Follow-Up

Double-check the fasteners to make sure all are properly torqued.

Test drive. To register your product for warranty purposes, go to the SuperSteer website at www.SuperSteerParts.com and fill out the online registration card

Re-check torque in 6 months.

**Your comments are greatly appreciated.
Please feel free to contact SuperSteer® at
888-898-3281 or e-mail at
Sales@SuperSteerParts.com**



A Division
of

