

Super Stanker™

REVISION
B

Industrial / Commercial
Sewer Tank / Vent Pipe Fan

GENERAL INFORMATION — Super Stanker™ is designed to create a slight vacuum inside sewage holding tanks and drain pipes that helps prevent odor infiltration into living areas. The fan's enclosure has the same outside dimensions as 4" Schedule 40 drain pipe, allowing it to be used with a pair of standard 4" rubber drain couplers (Fernco #1056-44 or similar) for easy attachment to 4" vent pipes. Other rubber coupler sizes can be used to adapt the fan for use with smaller vent pipe sizes. The fan can be mounted at any point along the vent pipe's run, at any angle — even upside-down. The brushless fan motor operates on safe, low-voltage DC power (a 120/240VAC to 13.5VDC power supply is included). A Fan Monitor constantly measures the fan motor's speed, sounding a warning beeper if the motor stalls. The motor is removable; replacements are available.

Two 13.5 VDC power supplies can be connected to the same fan. (Power supplies are separately available for this purpose.) In applications with dual sewage lift pumps, this allows the fan to operate whenever either pump is running, simply by plugging each power supply into separate wall outlets connected to each pump's AC control switch.

STEP-BY-STEP INSTALLATION INSTRUCTIONS

STEP 1: Determine the best mounting location for the fan (i.e., easy access to the vent pipe and a nearby 120/240 VAC wall outlet).

Note that the fan must be installed "downwind" of all feeder pipes, and must be located high enough to avoid direct exposure to sewage liquids.

Outdoor installation is not recommended, unless the fan is installed inside a weather-tight enclosure.

1.

STEP 3: Cut a 6-1/4" inch (160 MM) section out of the vent pipe at your intended installation point (use the Vent Pipe Cutting Gauge shown at right to measure the proper distance). **CAUTION:** Make sure the vent pipe is adequately supported from above before cutting it! Save this pipe section for temporary use when servicing the fan.

3.

STEP 4: Trim away any rough edges on both ends of the open vent pipe, and slip a rubber drain coupler over each of them. Next, slide the fan in place over the pipe ends (oriented so that the AIR FLOW arrow points toward the end of the vent pipe on the roof), slide the drain couplers into position (each coupler covering approx 2 inches of the fan enclosure), and tighten the hose clamps on the couplers.

4.

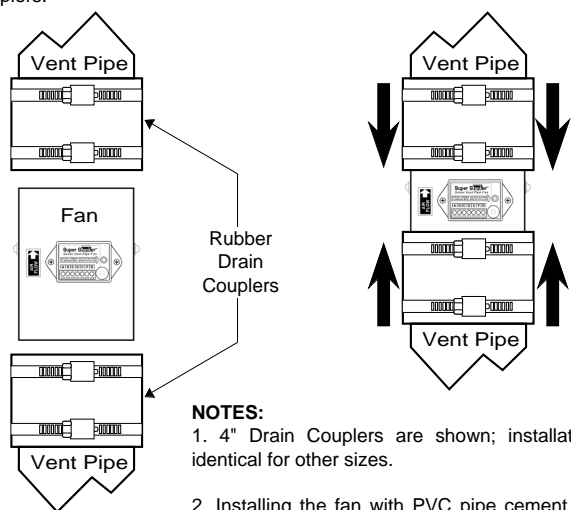

NOTES:
1. 4" Drain Couplers are shown; installation is identical for other sizes.
2. Installing the fan with PVC pipe cement is not recommended, since it would hinder any future attempts to remove the fan for repairs or cleaning.

STEP 2: If not already present, install a roof-mounted vent pipe cap, in order to keep debris and rainwater from falling down into the fan. A simple vent pipe cap can be made by cementing two 90 degree PVC elbows together, arranged so that the open end of the 2nd elbow faces downward:

2.

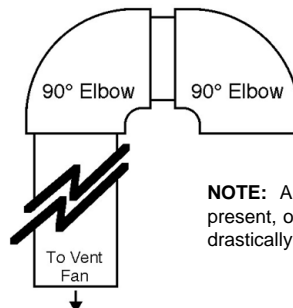

NOTE: A vent pipe cap **MUST** be present, or the motor's lifespan will be drastically reduced.

STEP 5: Strip 1/4" of insulation off the ends of the 13.5VDC Power Supply wires, and connect them terminals A and B on the Fan Monitor's wire connection block. (Either wire can go to either terminal, because the Monitor automatically provides the fan motor with the correct DC polarity). Connect the Fan Motor's BLACK (-) wire to terminal C, the RED (+) wire to terminal D, and the White or BLUE (Tach) wire to terminal E.

5.

NOTE: If using dual power supplies, connect the STRIPED wire on each power supply to the same terminal on the Fan Monitor, and the PLAIN (unstriped) wire on each power supply to the other terminal. This effectively connects both supplies in parallel, allowing the fan motor to run whenever either supply is receiving AC power.

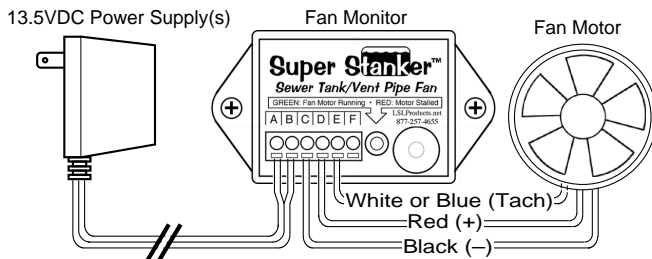

If operation of the warning beeper is not desired, connect a wire between terminals F and C. Otherwise, leave terminal F unconnected to anything.

Plug the 13.5VDC Power Supply into a 120/240VAC wall outlet. The Fan Monitor will briefly beep upon power-up, and the indicator LED will glow green to confirm that the fan motor is running.

This completes the installation procedure.

OPERATION — The LED indicator on the Fan Monitor glows green whenever the fan motor is operating at an adequate speed. If the fan motor stalls, the indicator LED will flash red instead, and the piezo beeper will sound approx. every 1 second (unless disabled as described in Step 5 above).

WARRANTY— LSL Products warranties this product for a period of ONE YEAR from the date of purchase against defects in materials and workmanship. In the event a problem, LSL Products will, at its option, repair or replace any defective components, at no charge to the owner. (The owner is responsible for the shipping charges associated with initial return of the product). IN THE EVENT OF A PROBLEM, PLEASE CONTACT US PRIOR TO RETURNING THE PRODUCT. This warranty does not cover damage due to unreasonable use of the product. IN NO EVENT SHALL LSL PRODUCTS NOR ANY OF ITS REPRESENTATIVES BE RESPONSIBLE FOR INCIDENTAL OR CONSEQUENTIAL DAMAGES. This warranty gives you specific legal rights, and you may have other rights which vary from state to state.

6-1/4 INCHES (160 MM)
Vent Pipe Cutting Gauge
Wire Strip Gauge
1/4"

SPECIFICATIONS

Supply Voltage: 100 - 240 VAC 50/60 Hz
Fan Motor Voltage: 12.0 VDC
Running Wattage: 5 Watts Max. @ 120 VAC
Air Flow: 42 CFM (Free-Air)

Noise Level: 27 dBA @ 36"
Weight: 22 Ounces
Motor Type: DC Brushless, Ball Bearings
Duty Cycle: Continuous

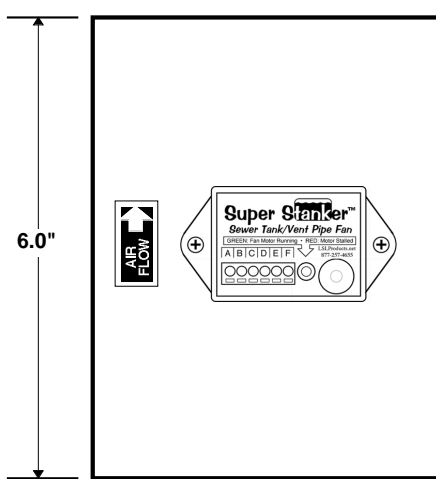

SIDE VIEW

(Note: Rubber Drain Couplers not shown)

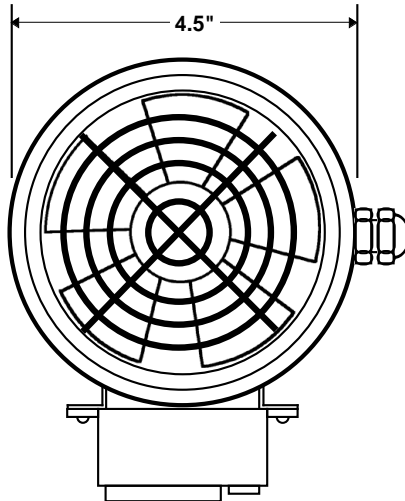

BOTTOM VIEW

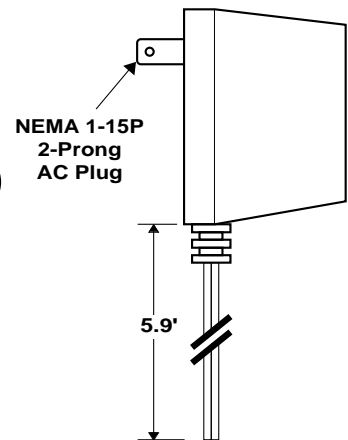

13.5VDC Power Supply

PARTS DIAGRAM

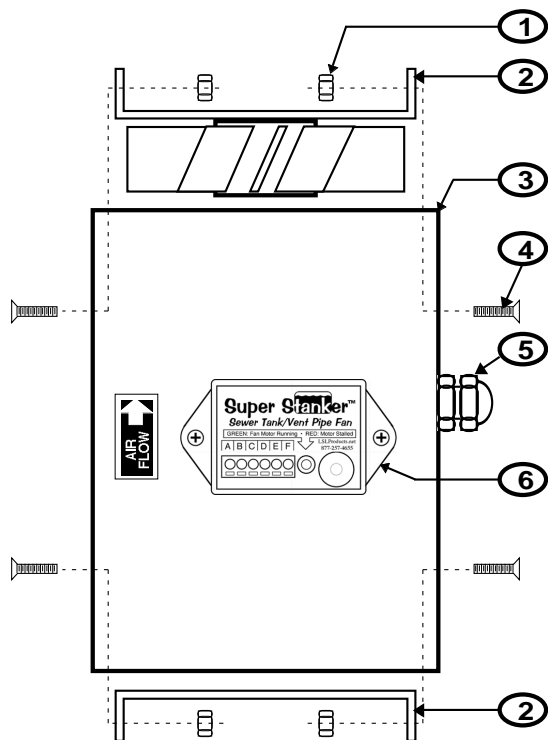

ITEM QTY. DESCRIPTION

ITEM	QTY.	DESCRIPTION
1	8	Nylock Nut, 18-8 SS, #8-32
2	1	Fan Motor Assy. w/Grills
3	1	Enclosure
4	8	Screw, 18-8 SS, #8-38 x 1" Flush
5	1	Strain Relief, Airtight
6	1	Fan Monitor Module
7	1	DC Power Supply, 13.5 VDC

