

DESCRIPTION

The Slater® decorator style self-contained device consists of a Body Assembly and a Back Cover. The body and cover are molded from Hi-Impact resistant thermoplastic resin. The body assembly contains brass terminals. The back cover is designed to provide strain-relief at the cable openings when the assembly is closed.

All device bodies are marked "White Wire" and "Black Wire" in the appropriate rear corners to identify the correct location for the installation of the cable conductors. In addition, there are raised ribs on one side of the device to further identify the "White Wire" (neutral) side of the device.

The top mounting brackets on all of the devices have a raised dimple to identify the top end of the device. This allows the installer to be consistent by having all switches turned "ON" when the upper half of the operating paddle is depressed. This raised dimple also allows consistency in the positioning of the receptacle ground pin. For 3-way switches, the "TOP" marking has no significance, other than to simplify wiring.

These features are provided to insure that wiring is in accordance with applicable electrical codes and standards.

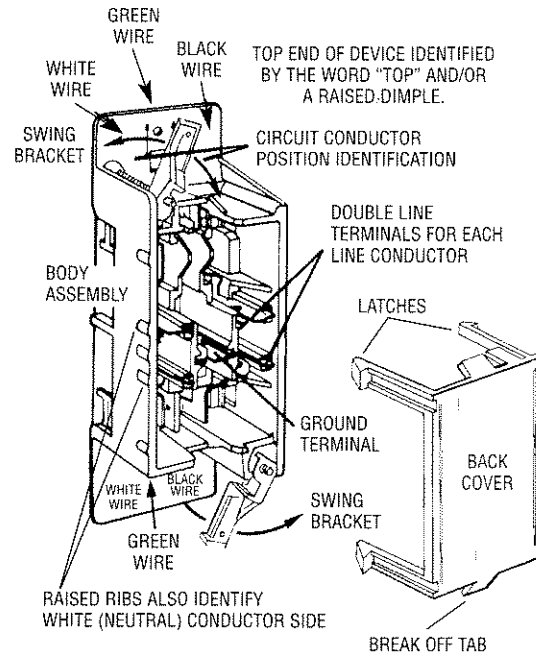

DEVICES RECEPTACLES



| | | CAT. NO |
|-----------|------------------|----------|
| Duplex | 15 Amp/125 Volts | SC080 |
| Decorator | 15 Amp/125 Volts | SC085 |
| Single | 15 Amp/125 Volts | SC821 |
| | | SC830 |
| | | SC830-S* |
| | 20 Amp/125 Volts | SC830-R* |

*Not Certified by Canadian Standards Association

SWITCHES

| | CAT. NO. |
|----------------------------|--------------------|
| 15 AMP 120 VOLTS AC | |
| S.P. (Single Pole) IN-LINE | SC070-S SC070-R |
| 3-WAY | SC073-S SC073-R |

JUNCTION

| | CAT. NO. |
|----------------|----------|
| 20A /125 VOLTS | SC014-S |

Listed by Underwriters Laboratories Inc. and Certified by Canadian Standards Association as flush-mounted self-contained switches and receptacles. Self-contained devices are also UL, Listed and CSA Certified for surface mounting.

"S" suffix devices are for use on plasterboard $\frac{3}{8}$ " to $\frac{1}{2}$ " thick, and wood or composition paneling $\frac{3}{8}$ " to $\frac{1}{2}$ " thick.

"M" suffix devices are for surface mounting on wood or steel studs.

"R" suffix devices are replacement units for the same mounting limitations as "S" suffix devices and are supplied with a closing tool for installing the back cover.

Additional suffixes "1", "2", "3", "4", "5" and "6" identify device colors **Brown, Ivory, White, Light Almond, Gray** and **Black** respectively.

Receptacles and single-pole switches are for use with two wire (with ground) nonmetallic sheathed cable.

Three-way switches are limited to use in circuits where the branch circuit power cable is installed at the load location. See wiring diagram on Page 8 for illustration.

WALL CUTOUT

USE DIMENSIONS
SHOWN BELOW

NOMINAL CUTOUT DIMENSIONS

| | |
|--------------|----------------------------------------|
| Single gang: | 3 $\frac{3}{8}$ " x 1 $\frac{1}{16}$ " |
| Two gang: | 3 $\frac{3}{8}$ " x 3 $\frac{1}{2}$ " |
| Three gang: | 3 $\frac{3}{8}$ " x 5 $\frac{5}{16}$ " |
| Four gang: | 3 $\frac{3}{8}$ " x 7 $\frac{1}{8}$ " |
| Five gang: | 3 $\frac{3}{8}$ " x 8 $\frac{1}{16}$ " |
| Six gang: | 3 $\frac{3}{8}$ " x 10 $\frac{1}{4}$ " |

SLATER® "SCD" INSTALLATION TOOL

The Slater hand tool catalog number SCD-TOOL is designed to slit and form flat nonmetallic sheathed cable (NMB, NMC, NMD and NMD90* copper cable #12-2 and #14-2 with ground) and to install the cable into the self-contained device body assembly.

*CSA DESIGNATION

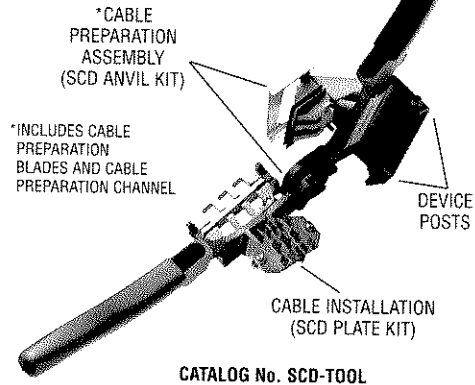

CABLE PREPARATION

SLITTING AND FORMING THE CABLE

Slitting the cable jacket with the Slater SCD-TOOL forms each conductor to match the inner terminal configuration of the switch or receptacle. The tool will produce a slit length of less than 2.05" maximum allowable slit. Prepare conductors as illustrated in the section "Cable Installation for Receptacles/Junctions & Switches."

12-INCH LOOP AND 6-INCH END-OF-LINE

Where an In-Line cable is located at a device opening in a wall, there must be at least a 12" length of cable available on the room side of the wall to allow cable preparation and possible future device replacement (NEC Requirement). For end-of-line, power tap or splice applications, a minimum 6" length of cable must be available on the room side of wall. For all installations the cable must be secured within 12" from the wiring device wall opening.

1. With tool handles opened, place cable in the cable guide of cutter section. Be sure cable lies flat in the cable guide.
2. Grip tool handles and squeeze together until tool is fully closed (handles are parallel.)
3. Open tool handles fully and carefully remove the formed cable.

NOTE: After slitting, if cable is to be used for an In-Line receptacle, it is ready for installation. It is not necessary to remove the cable sheathing or paper filler. For all other applications, trim outer sheathing and paper filler from the slit length. Refer to "CABLE INSTALLATION FOR RECEPTACLES/JUNCTIONS & SWITCHES" for details of wiring methods.

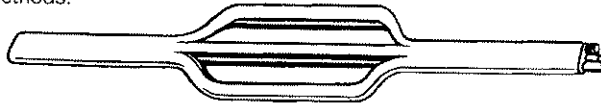

CABLE INSTALLATION FOR RECEPTACLES/JUNCTIONS & SWITCHES

WARNING: Do not join two (2) different wire sizes in a self-contained receptacle or switch.

RECEPTACLES/JUNCTIONS

(CAT. NOS. SC080, SC085, SC014, SC821, SC830)

IN-LINE RECEPTACLE

Single cable running through a receptacle. The cable may be installed with the sheath and paper filler left in place. If a second level of cable is anticipated (i.e. power tap) all the sheath material and paper filler must be removed from the entire slit length of each cable.

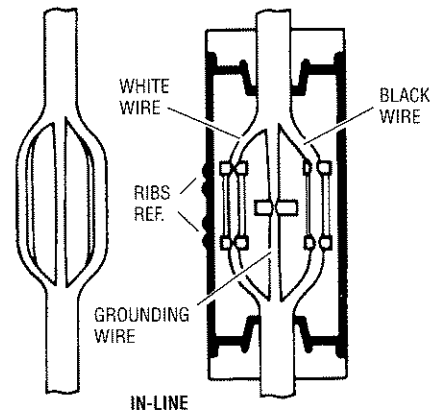

END-OF-LINE RECEPTACLE

An end-of-line receptacle must have each line conductor extending approximately $\frac{1}{4}$ " beyond its double line terminal as shown.

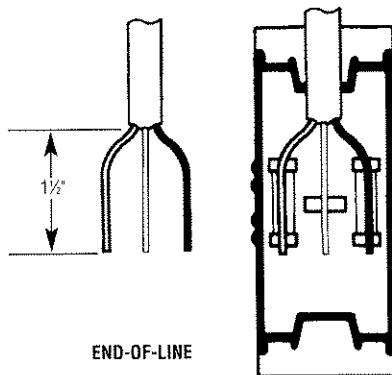

SPLICE

A splice is an installation where two (2) cable ends terminate in a SCD — i.e. one cable bringing power to a receptacle or junction and a second cable going to another load.

NOTE 1: Each circuit conductor of the cable ends must be installed so that it engages its respective double line terminals as shown.

NOTE 2: Two cables may exit from opposite ends of device as shown, or from one end only. (not shown)

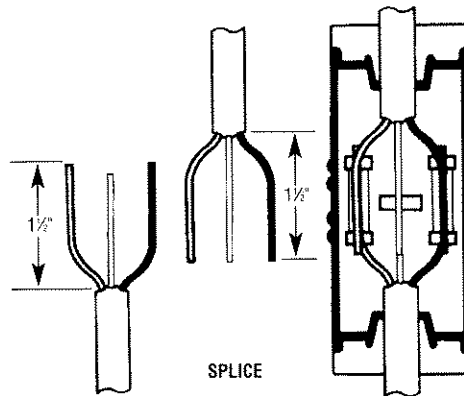

NOTE: All cable installations shown must have all sheath material and paper filler removed from the entire slit length of the cable.

(Continued on next page)

CABLE INSTALLATION FOR RECEPTACLES/JUNCTIONS & SWITCHES (Con't)

NOTE: All cable installations shown on this page must have all sheath material and paper filler removed from the entire slit length of the cable.

RECEPTACLES/JUNCTIONS

(Continued)

POWER TAP

A power tap is an application using a self-contained device with a second level of conductors installed in the device terminals on top of the branch circuit cable. The power tap may be an in-line cable (one cable going out each end of the receptacles to two other load locations), or may be a single cable going to one load location. In the latter case, each circuit conductor must be installed with approximately $\frac{1}{4}$ " extending beyond its double line terminal as shown.

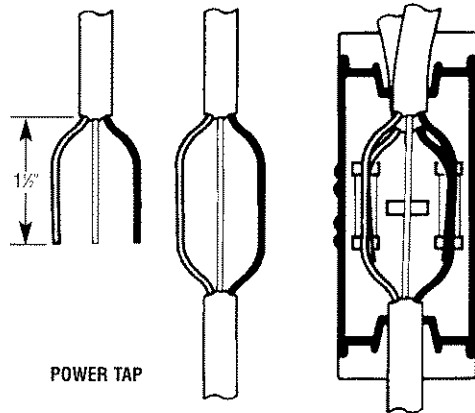

POWER TAP AND SPLICE

A power tap may be made on a receptacle or junction which is used for splicing two cable ends. For #12 cable, the wire insulation must be stripped from two of the three conductors as shown in "A" and "B". It is not mandatory to strip the wire insulation off the conductors when using #14 cable. The stripped conductor cables "A" and "B" must be installed in the receptacle body first, one on top of the other. Conductor cable "C" which has not been stripped must be placed in last, on top of the stripped conductors.

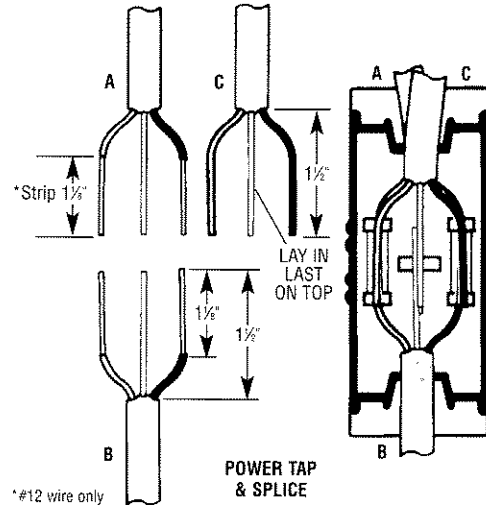

SWITCHES

IN-LINE (CAT. SC070)

The black insulated conductor of the single cable running through the device must have a short length cut out (approx. $\frac{1}{4}$ " to $\frac{3}{8}$ ") between terminals and all the sheath material and paper filler must be removed from the entire slit length of the cable.

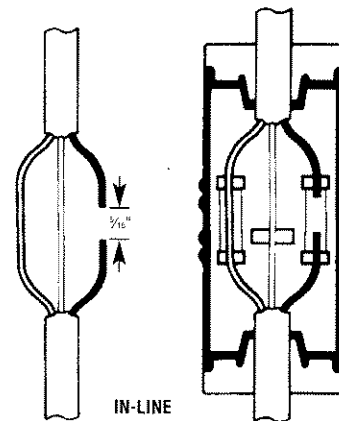

(Continued on next page)

CABLE INSTALLATION FOR RECEPTACLES/JUNCTIONS & SWITCHES *(Con't)*

NOTE: All cable installations shown on this page must have all sheath material and paper filler removed from the entire slit length of the cable.

SWITCHES *(Continued)*

POWER TAP (CAT. SC070)

A power tap is an application using an in-line switch for a second level of conductors installed in the device terminals under the in-line cable.

The power tap may be either switch controlled or always energized by installing the tap under the "load-end" or "feed-end" of the first level cable. Be certain to maintain continuity of the grounding conductor to the load when installing a power tap.

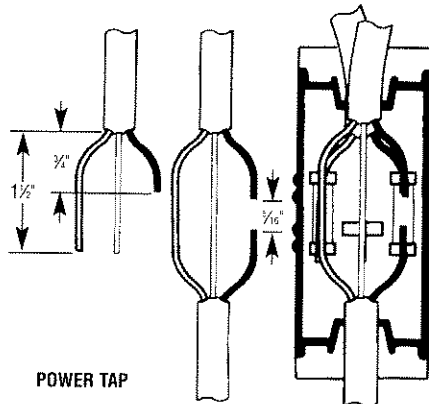

POWER TAP (CAT SC070)

The power tap cable may provide one switched end and one always energized if it is also a feed-through cable. (Black conductor of both levels of cable must be severed as shown.)

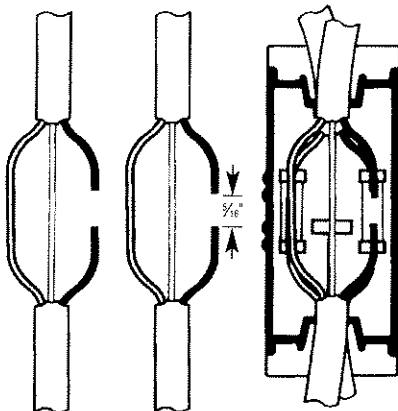

POWER TAP AND SPLICE (CAT. SC070)

A power tap may be made on a switch which is used for splicing 2 cable ends. This tap may also be either switch controlled or always energized. All three grounding conductors must be joined in the ground terminal. For #12 cable, the wire insulation must be stripped from two of the three conductors as shown in "A" and "B". It is not mandatory to strip the wire insulation off the conductors when using #14 cable. The stripped conductor cables "A" and "B" must be installed in the switch body first, one on top of the other. Conductor cable "C" must be placed in last, on top of the stripped conductors.

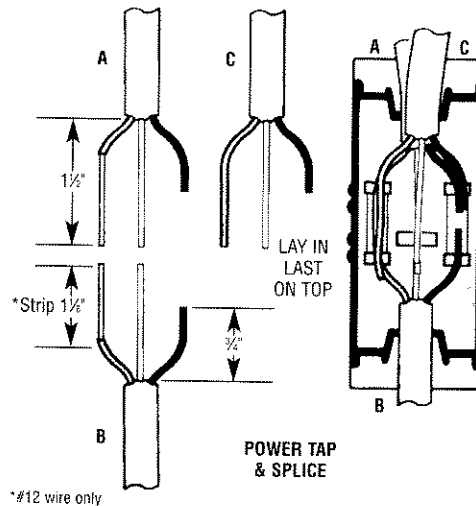

CABLE INSTALLATION FOR RECEPTACLES/JUNCTIONS & SWITCHES *(Con't)*

NOTE: All cable installations shown on this page must have all sheath material and paper filler removed from the entire slit length of the cable.

SWITCHES *(Continued)*

SPLICE (CAT SC070)

A splice is an installation where two (2) cable ends terminate in a SCD — i.e. one cable bringing power to a switch and a second cable going to the load. A device used to splice two (2) cables can also provide a POWER TAP (see page 6).

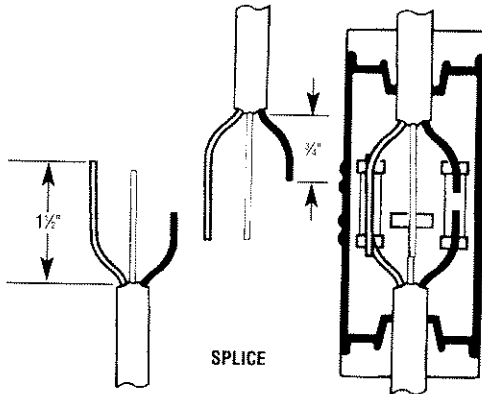

END-OF-LINE (ALTERNATE INSTALLATION WITH CAT. SC070)

A Cat. No. SC070 may be used for an end-of-line installation by looping the white conductor and terminating as shown. Cut off ground conductor flush with cable sheath. The ground terminal will not be used for end-of-line installations.

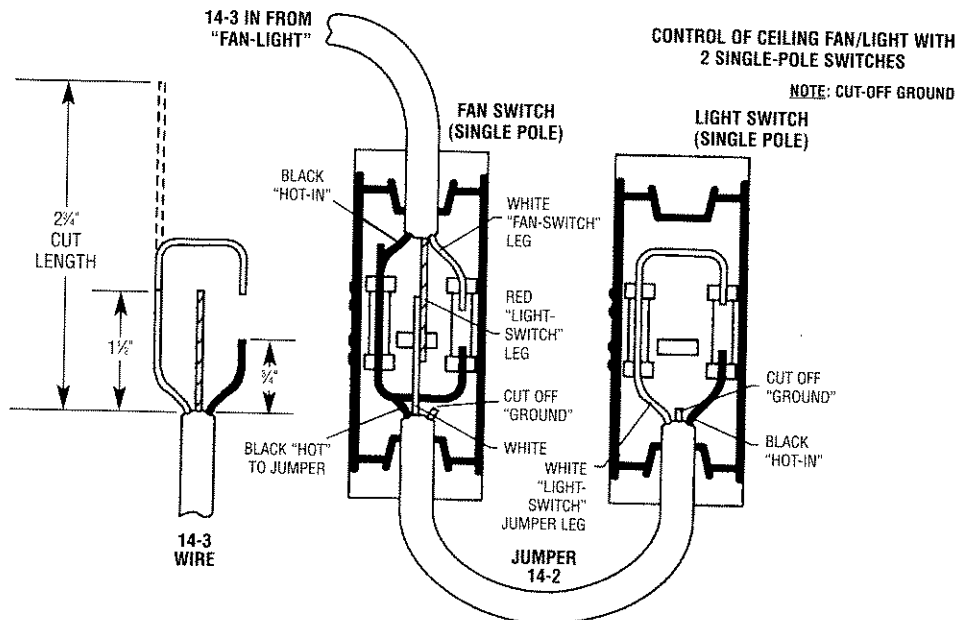
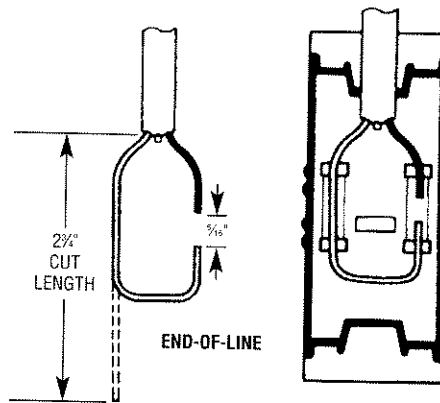

CABLE INSTALLATION FOR RECEPTACLES/JUNCTIONS & SWITCHES *(Con't)*

NOTE: All cable installations shown on this page must have all sheath material and paper filler removed from the entire slit length of the cable.

SWITCHES *(Continued)*

3-WAY SWITCHES (CAT. SC073)

The power feed cable is run to the load. A two wire cable is run from load to the first 3-way switch and a three wire cable is run from first to second 3-way switch (see diagram). The branch circuit power cable must be installed at the load location as shown.

NOTE: Ground conductors should be cut off with cable sheath at both ends of cables connected to three-way switches.

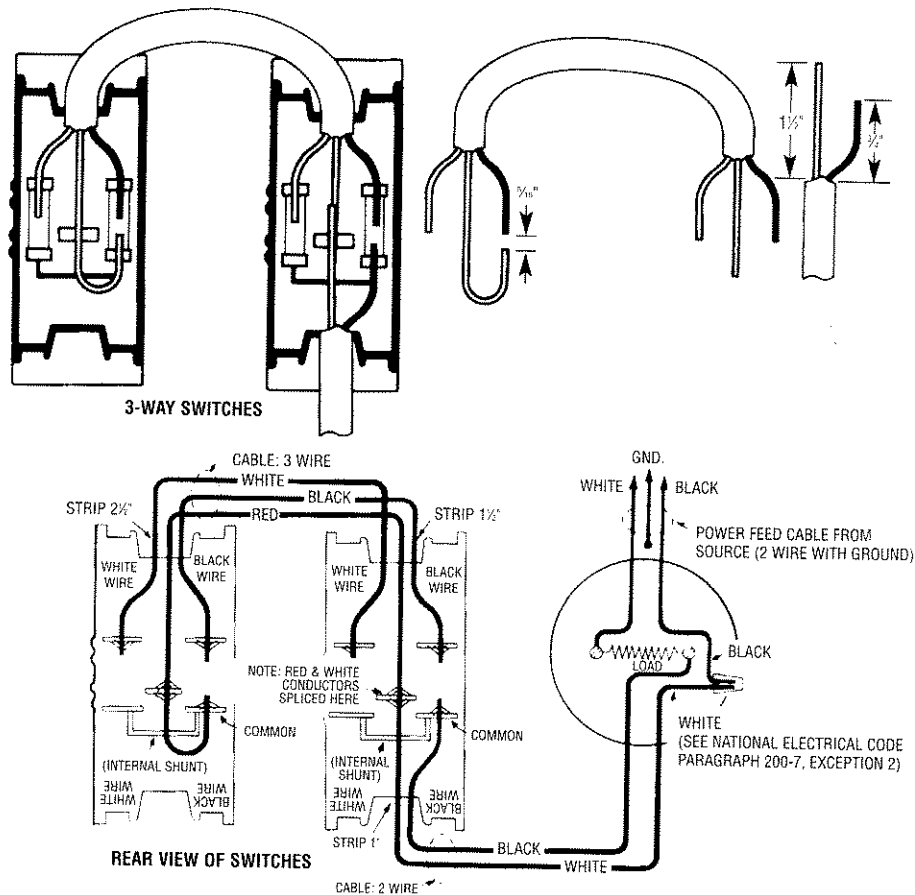

WARNING: Do not join two different wire sizes in a self-contained device. (i.e. 14-3 wire to be used only with 14-2 and 12-3 with 12-2).

COMPLETING THE INSTALLATION

USING INSTALLATION TOOL NO. SCD-TOOL

- 1.** Insert the device to be wired face down onto the device posts of the SCD-TOOL.
- 2.** Carefully position the conductors over the device terminals. By fully closing the tool handles, the Cable Installation Plate will push the cable conductors into the device terminals. For additional layers of cable, repeat the process.
- 3.** After all cables have been installed, inspect the wire lay, and if satisfactory, snap the back cover into the device. The device is now ready to be installed in the wall.

BACK COVER

The back cover may be used for either a switch or a receptacle, and may be installed in either possible orientation on the device. As molded, the back cover allows an opening for one cable and when installed in the body assembly. For additional cable openings, break off tabs as follows:

- For in-line or end-of-line 1 cable in and 1 cable out configuration, break off one level of the longer tab.
- For power tap or power tap and splice configuration with 2 cables in and 1 cable out configuration break off the longer tab.
- For power tap with 2 cables in and 2 cables out configuration break off the long and short tabs.

NOTE: To comply with N.E.C. requirements, there must be no unoccupied cable openings in the installed device.

CAUTION: Each cable opening is not intended for more than two cables.

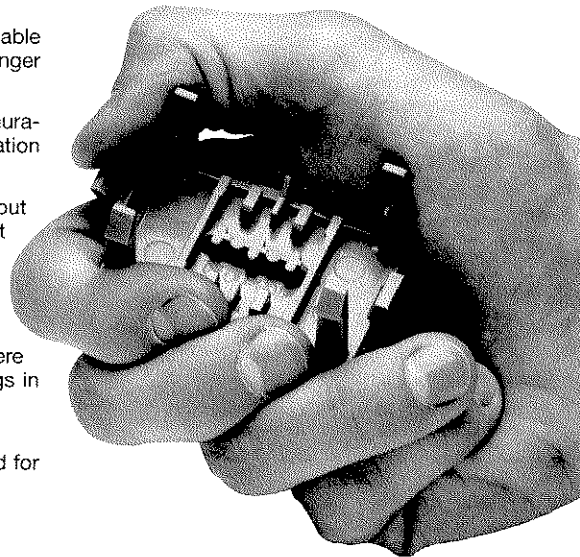

SWING BRACKET MOUNTING

(Cat. No. with Suffix "S" or "R")

The Slater® swing bracket devices are designed for use on dry wall $\frac{3}{8}$ " to $\frac{1}{2}$ " thick, and on wood or composition paneling $\frac{1}{2}$ " to $\frac{5}{8}$ " thick.

1. Push the device into the dry wall or panel cutout until the mounting bracket is flush against the wall surface.
2. Using a number 2 type 1A "Posidriv"® screwdriver, turn the screw head clockwise (which turns the swing bracket to the upright position) and tighten the swing bracket until the device is secured to the wall.

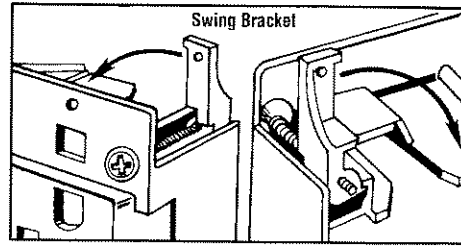

IMPORTANT NOTE:

This device can be installed anywhere between studs. If mounted adjacent to a stud, no additional space is necessary to clear travel of swing bracket.

SURFACE MOUNTING

Slater self-contained devices are UL Listed and CSA Certified for surface mounting on wood and steel studs.

(Cat. No. with Suffix "S" or "R")

1. Remove the two screws and swing brackets from the device by backing out the screws through the front of the device.
2. Replace the screws removed in Step 1 with two #6 x minimum $1\frac{1}{2}$ " long wood screws or sheet metal screws.
3. Secure the device to the mounting surface.

(Cat. No. with Suffix "M")

1. Insert two #6 x $1\frac{1}{2}$ " self-tapping screws (supplied in device carton) into the round openings on the face of the device.
2. Secure the device to the mounting surface.

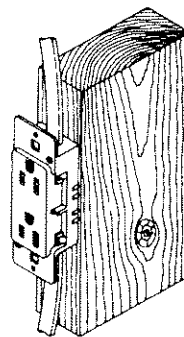

WOOD STUD MOUNTING

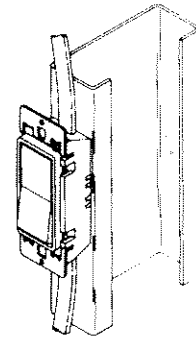

STEEL STUD MOUNTING

REPLACING A SELF-CONTAINED DEVICE

If a SCD should require replacement, use one of the following replacement devices:

| | |
|---------|----------------------------|
| SC070-R | Single Pole In-Line Switch |
| SC073-R | Three-Way Switch |
| SC085-R | Decorator Receptacle |
| SC821-R | Single 15 AMP Receptacle |
| SC830-R | Single 20 Amp Receptacle |

GANGING PROCEDURES

Install in wall as follows:

A. TWO-GANG

1. Position devices next to each other in wall cutout made by using 2-gang routing template, Cat. No. SCT-2T
2. Snap positioning guide, Cat. No. SCT-7 onto devices. This will automatically position and space devices. Secure devices to wall and remove positioning guide. Install wall plate.

B. THREE-GANG

1. Position devices next to each other in wall cutout made by using 3 gang routing template, Cat. No. SCT-3T
2. Snap positioning guide, Cat. No. SCT-7 onto two devices. This will automatically position and space two devices. Secure devices to wall and remove positioning guide.
3. Snap positioning device onto remaining device and the one adjacent to it (already installed). Secure the third device to wall and remove positioning guide. Install Standard Decorator screw mounted wall plate.

C. FOUR, FIVE OR SIX-GANG

1. Position device in wall cutout specified on page 3 and proceed as described in B. Use Standard Decorator screw mounted wall plate (see below).

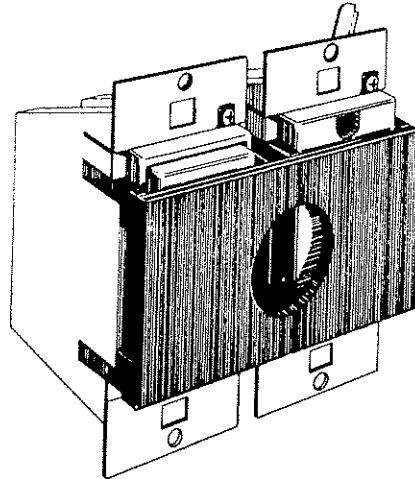

SNAP-ON WALL PLATES

Designed to be used in conjunction with any one or two gang Slater® SCD installations.

To install a SNAP-ON WALL PLATE:

1. Align wall plate locking tabs to square holes in mounting straps.
2. Press firmly until locking tabs snap into place.

To remove wall plate, pry outward until locking tabs release. The plate can be removed and reinstalled without loss of retention force.

Single gang and double gang screw mounted wall plates may be used instead of snap-on wall plates, if preferred.

| DESCRIPTION | CAT. NO. | COLOR |
|-------------|----------|--------------|
| Single Gang | SNAP-11 | Brown |
| | SNAP-12 | Ivory |
| | SNAP-13 | White |
| | SNAP-14 | Light Almond |
| Two Gang | SNAP-21 | Brown |
| | SNAP-22 | Ivory |
| | SNAP-23 | White |
| | SNAP-24 | Light Almond |

SCREW MOUNTED WALL PLATES

For ganged installation, use screw mounted wall plates. (Single and double (two) gang screw mounted wall plates may be used instead of snap-on wall plates, if preferred.)

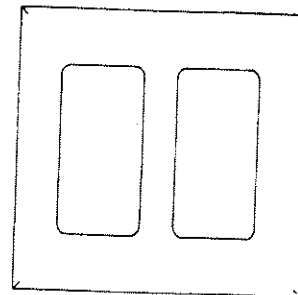
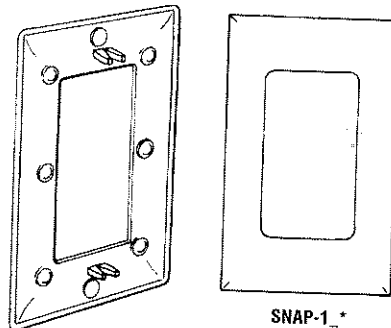

* Replace "_" with color number to specify color choice:
1-Brown, 2-Ivory, 3-White, 4-Light Almond