



# BLUE OX®

Baseplate Installation Instructions

## BX2322

# 2004 Hyundai Santa Fe Installation Instructions

Serial Number

**Please read BOTH these Installation Instructions and the General Instructions before attempting to install or operate this equipment.**

1. Blue Ox® towing products and accessories are intended to be installed by Blue Ox® Dealers who are familiar with our products and have the necessary equipment and knowledge to do "fit work". When necessary Blue Ox® Dealers can be found at [www.blueox.us](http://www.blueox.us) or by contacting our 24/7 Customer Care Department at (402) 385-3051.
2. Many Blue Ox® baseplates are designed to use existing holes and hardware to mount the baseplate to the towed vehicle. Even though bolts are there, do not assume they are adequate for baseplate mounting. Always use hardware supplied in the hardware kit and existing hardware specified in the Baseplate Installation Instructions.

Attachment Tab Height: 22 1/2"  
Attachment Tab Width: 19"

**Bolt Torque Specifications**  
Torque in Foot-Pounds per Metric Bolts

Bolt Size	Grade 8.8	Grade 10.9
6MM	6	8
8MM	16	22
10MM	31	40
12MM	54	70
14MM	89	117

Confirm the towability and pre-towing procedures for your vehicle with the owner's manual or contact the vehicle's manufacturer for specific towing procedures. You can also contact REMCO for additional information at 1(800)228-2481.

**Bolt Torque Specifications**  
Torque in Foot-Pounds per Inch Bolts

Bolt Size	Grade 5	Grade 8
1/4"	10	14
5/16"	19	29
3/8"	33	47
7/16"	54	78
1/2"	78	119
5/8"	154	230



**! WARNING**

Failure to read and follow these instructions could result in separation of the towed vehicle from the tow bar, causing property damage, loss of towed vehicle, personal injury or death.

# BX2322

## 2004 Hyundai Santa Fe

### Installation Instructions

### Parts List

Ref. No.	Qty.	Part #	Description
1	1	61-6214	Weldment, Baseplate, BX2322
2	6	61-5208	3/8" Nutplate, with 14" Wire
3	6	201-0440	3/8-16 x 1 1/2" Bolt, Grd. 5, ZP
4	6	203-0010	3/8" Lock Washer, ZP
5	2	201-0979	#12-14 x 1" Self Drilling Screw, ZP
6	2	201-0192	#10-32 x 1/2" Slot, Rd.Hd. Screw
7	2	203-0054	#10 Lock Washer
8	2	202-0047	#10-32 Hex Nut
9	2	101-5822	Adapter, 4 Way Connector
10	2	62-3468	Att Tab Assy, Rem, SF/SB, 1 Hole
	2	226-0046	Baseplate Safety Cable, 36" CL III (NS)
	2	229-0359	Quicklink, 3/8, ZP (Not Shown)
	2	290-0437	Cap Plug (Not Shown)

### Tools Required

Phil  
Smal

Re  
Fl

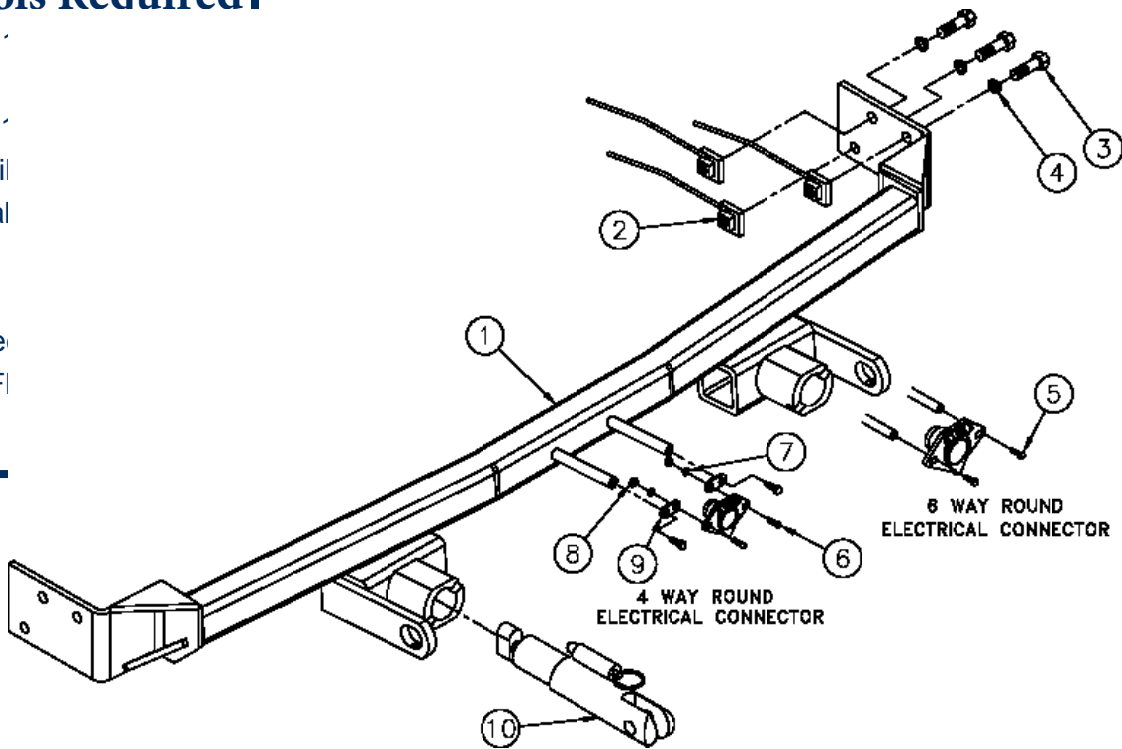

### Important:

Use only genuine factory replacement parts on your baseplate. Do NOT substitute homemade or non-typical parts. If a bolt is lost or in need of replacement, for your safety and the preservation of your baseplate, be sure to use a replacement bolt of the same grade. In most cases it will be Grade 5—please reference the parts list above. Replacement parts may be ordered through your nearest Blue Ox® dealer or distributor, or call our 24/7 Customer Care Team at (402)385-3051 or toll free (888) 425-5382.

# BX2322

## 2004 Hyundai Santa Fe

### Installation Instructions

#### Attachment Tabs:

Due to the design of the removable tabs, the RangeFinder II, Adventurer, and Ambassador tow bars can not be used. Adapters, except the BX8833 and the BX88151, can not be used with this baseplate.

#### Instructions:

The headlight assembly and front fascia are removed for baseplate installation. Drilling is required.

The dimensional variations between otherwise identical vehicles can be considerable. Although the baseplate was designed for easy installation, it may be necessary to tailor the baseplate slightly to compensate for auto manufacturer's tolerances. These minor adjustments may include filing a hole slightly, bending electrical rods, and/ or bending end plates.

The BX8869 Bulb and Socket Wiring Kit is recommended for this vehicle.



1. Remove six Phillips pushpins from the top edge of the fascia. Set pushpins aside to be reinstalled later.



2. Just forward of the front tire is one Phillips screw to remove with the Phillips screwdriver. Do this to both sides of the vehicle. Set screws aside to be reinstalled later.

BX2322  
2004 Hyundai Santa Fe  
Installation Instructions



3. Remove the two Phillips screws just forward of the front tire, on the underside of the fascia, with the Phillips screw driver. Do this to both sides of the vehicle. Set screws aside to be reinstalled later.

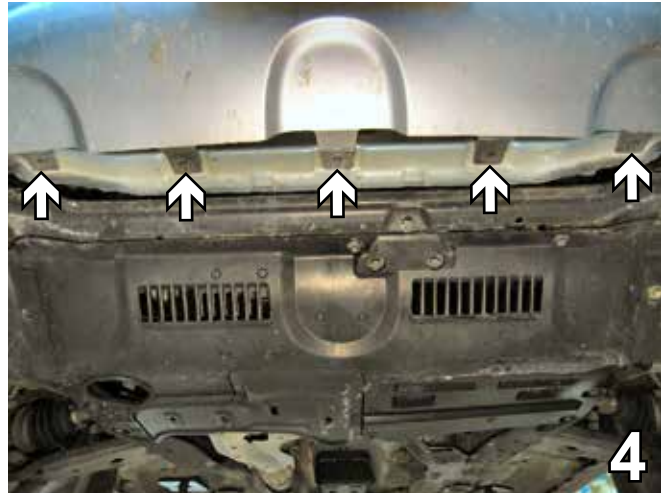

4. Remove the five metric bolts from the lower edge of the front fascia with the 10MM Socket. Set bolts aside to be reinstalled later.



5. Using the 10MM socket, remove the three metric bolts from the headlight assembly. Pull assembly forward and unplug electrical connections. Do this to both sides of the vehicle. Set headlight assemblies and metric bolts aside to be reinstalled later.



6. Just below headlight assembly is a Phillips pushpin to remove. Do this to both sides of the vehicle. Set pushpins aside to be reinstalled later. Pull fascia corner out to the side and then forward. Unplug marker lights and unplug fog light, if applicable. Set fascia aside to be reinstalled later.

# BX2322

## 2004 Hyundai Santa Fe

### Installation Instructions



7. Mark two horizontal lines, one  $3\frac{3}{4}$ " and one  $\frac{5}{8}$ " down from the top edge of frame's front edge. Mark a vertical line flush with the outside edge of the frame. Remove this area with the Reciprocating Saw. Do this to both sides of the vehicle. Using a good quality paint, spray all cut edges of the frame to prevent rusting.

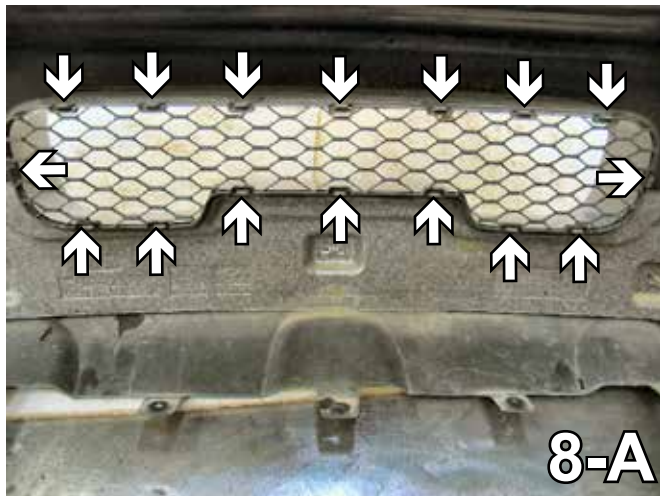

8. Set the front fascia face down on a soft surface to protect it from being scratched. Using a small flat screwdriver, release the sixteen clips from the grille, shown in 8-A. Remove the side clip from the fascia with a utility knife 8-B. The **GRILLE** will **NOT** be reinstalled.

# BX2322

## 2004 Hyundai Santa Fe

### Installation Instructions

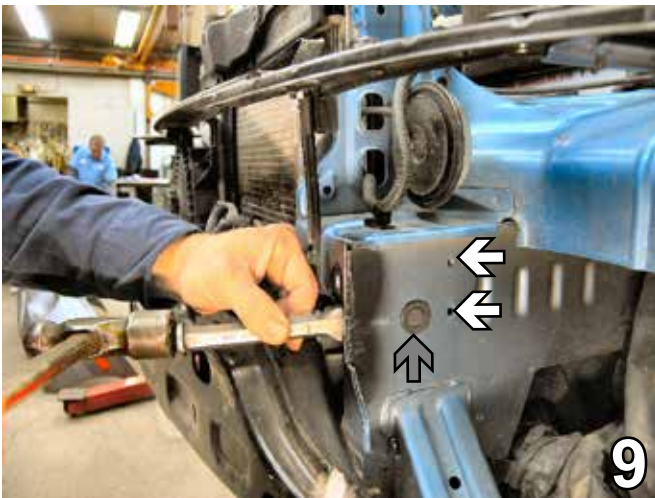

9. Remove the two weld nuts from the existing holes inside the frame with the Flat Cold Chisel, see grey arrow in the photo above. Remove the rubber plug from the frame, please reference the white arrows in the photo above. Do this to both sides of the vehicle. Plugs will NOT be reinstalled.

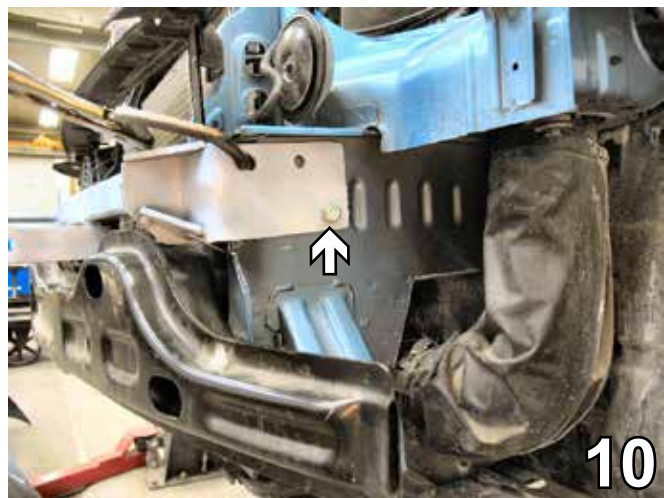

10. Slide the baseplate on the frame to align lower back hole with the existing lower hole in the frame. Clamp in place with the a vise grip to the frame. Align passenger's side of baseplate to the same location on the frame and clamp in place. Using the baseplate as a template, ream out the existing hole with the 13/32" drill bit. Insert the 3/8" nut plate into the opening on the end of the frame to align with the drill hole. While maintaining a level position with the frame, tighten the 3/8" lock washer and 3/8-16 x 1 1/2" hex bolt into the nut plate. Do this to both sides of the vehicle.

**\*\*BE SURE TO USE LOCTITE® RED ON ALL BOLTS BEFORE TIGHTENING. TIGHTEN ALL BOLTS ACCORDING TO THE TORQUE CHART ON THE FRONT PAGE OF THESE INSTRUCTIONS OR ON PAGE 3 OF THE BASEPLATE TOWING GENERAL INSTRUCTIONS.**

**BASEPLATE IS PAINTED WHITE TO INCREASE VISIBILITY IN PHOTOS.**



11. Using the baseplate as a template, drill the two remaining holes with the 13/32" drill bit. Do this to both sides of the vehicle.



12. Insert the 3/8" nut plates into the opening on the end of the frame to align with drilled holes. Tighten the 3/8" lock washers and the 3/8-16 x 1 1/2" hex bolts into the nut plates., Do this to both sides of the vehicle.

# BX2322

## 2004 Hyundai Santa Fe

### Installation Instructions

13. Reinstall the headlight assemblies and the fascia. Be sure to reconnect all electrical connections to fascia and headlights. Installation of baseplate is complete.

Instal the tow bar and safety cables according to the instructions included in their packages.

Do **NOT** substitute other devices if the tow bar pin and clip is lost

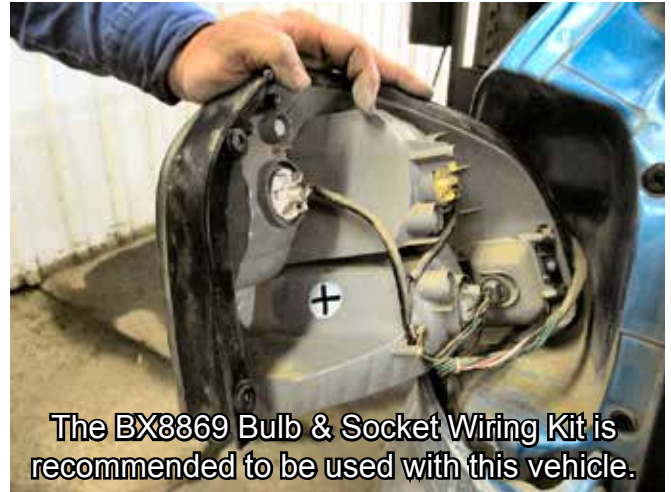

The BX8869 Bulb & Socket Wiring Kit is recommended to be used with this vehicle.



With removable tabs installed.



With removable tabs installed.

BX2322  
**2004 Hyundai Santa Fe**  
Installation Instructions

## **Customer Service Commitment**

Blue Ox® is focused on providing exemplary customer service, as observed in our mission statement and guiding principles. In accordance with this objective, Blue Ox® is proud to provide services such as repairs and general maintenance of Blue Ox® products at over 150 RV Rallies. Look for our Destination America or Blue Ox® Racing service crews at the next rally or race that you attend. If you were not present, you will find an informative, personalized note explaining any services that may have been performed to your Blue Ox® products.

Blue Ox® also offers educational seminars at rallies and through our Park and Resort teams. In addition, Blue Ox® customers visiting our factory may take advantage of the well-equipped Blue Ox® RV park at no charge to you, our valued and appreciated customer.



© 2005 Blue Ox  
One Mill Road, Industrial Park  
Pender, Nebraska 68047  
Phone: (402) 385-3051  
Fax: (402) 385-3360  
[www.blueox.us](http://www.blueox.us)



# General Information

1. Ensure that your product(s) are registered online at [www.blueox.com](http://www.blueox.com). It is crucial to register your product(s) so that you may be alerted of product offerings, updates, upgrades, maintenance and safety bulletins, and/or recalls.
2. **It is the owner's responsibility to inspect all towing equipment for cracked welds, missing or worn parts and loose bolts before each towing trip.** Be sure to use Loctite® Red on all bolts and tighten to the recommended specifications.
3. **It is the owner's responsibility to hook up all towing equipment per manufacturer's instructions/recommendations.**
4. Remove the attachment tabs when not in use (if applicable).

## Notice To Baseplate Installer

### 1. It is YOUR responsibility to watch for:

- Oil cooler and air conditioner lines
- Electrical wires and hoses
- Missing parts or attaching points on the frame

\*\* If the baseplate is improperly installed and is against a wire or hose, it could cause fluid leaks or electrical shorts some time after the actual baseplate installation.

## Permanent Baseplate Safety Cable Installation

Permanent baseplate safety cables are strongly recommended when towing a vehicle with a tow bar. The principle function of the permanent baseplate safety cables is to prevent the towed vehicle from breaking loose in the event the connection between the frame of the towed vehicle and the baseplate fails or becomes disconnected. The cables must be connected from the baseplate to the frame rail or cross member of the vehicle's frame. The illustrations below show the possible arrangements recommended by Blue Ox®. Each permanent baseplate safety cable must have an adequate weight rating for the towing system. The weight rating of the two (2) cables together will not qualify.

***Do not mount the permanent baseplate safety cables against wires, hoses or brake lines.***

These permanent baseplate safety cables should remain installed as long as the baseplate is installed on the vehicle. Permanent baseplate safety cables are to be used in conjunction with, and NOT a replacement for legally required safety cables attaching the towed vehicle to the towing vehicle.

### OPTION #1

Permanent Baseplate Safety Cables to Cross Member or Frame of Towed Vehicle.

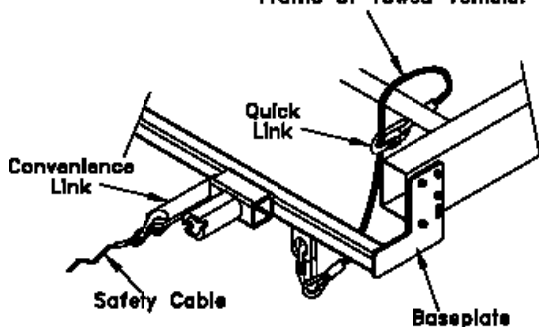

### OPTION #2

Permanent Baseplate Safety Cables to Cross Member or Frame of Towed Vehicle.

