



# CHILLGRILLE

COLEMAN®-MACH® AIR CONDITIONERS

**INSTALLATION INSTRUCTIONS  
FOR  
8330A6321 CHILLGRILLE™  
WITH MOUNTING KIT**

- 8330-752 CONTROL BOX KIT (12 VDC COOL ONLY)**
- 9330A755 CONTROL BOX KIT (12 VDC HEAT/COOL)**
- 8530-750 CONTROL BOX KIT (24 VAC COOL ONLY)**
- 9530A751 CONTROL BOX KIT (12 VDC HEAT PUMP)**
- 9530A755 CONTROL BOX KIT (12 VDC HEAT PUMP)  
WITH BACKUP ELECTRIC HEAT**
- 8330B751 ZONE CONTROL KIT (12 VDC COOL ONLY)**
- 8330C755 ZONE CONTROL KIT (12 VDC HEAT/COOL)**
- 8530C751 ZONE CONTROL KIT (12 VDC HEAT PUMP)**
- 9330-752 IR CONTROL KIT (12 VDC COOL ONLY)**
- 9330-757 IR CONTROL KIT (12 VDC HEAT/COOL)**
- 9530-757 IR CONTROL KIT (12 VDC HEAT PUMP)**

DESIGNED AND MANUFACTURED BY THE MAKERS OF  
COLEMAN®-MACH® AIR CONDITIONERS



# TABLE OF CONTENTS

Warnings .....	2
Package Contents .....	2
General Information .....	3
Ceiling Plenum Installation Requirement .....	3
Control Box Kits .....	5
Control Box Kits (Zone) .....	5
Control Box Kits (Infrared Remote) .....	6
Wall Thermostats .....	6
Supply Ducting And Registers .....	6
Routing Thermostat Wiring .....	7
Routing Thermostat Wiring (Zone) .....	7
Routing IR Wiring .....	8
Routing 115 VAC Wiring .....	8
Ceiling Plenum Mounting .....	9
Installing The Control Box .....	10
Installing The Control Box (Zone) .....	11
Installing The Control Box (IR) .....	13
Installing The Heater Assembly .....	15
Install Air Grille Assembly .....	16
Mounting And Configuring The Handheld Transmitter .....	16

## WARNINGS

### IMPORTANT NOTICE

These instructions are for the use of qualified individuals specially trained and experienced in installation of this type equipment and related system components.

Installation and service personnel are required by some states to be licensed. **PERSONS NOT QUALIFIED SHALL NOT SERVICE THIS EQUIPMENT.**

### WARNING

Improper installation may damage equipment, can create a hazard and will void the warranty.

The use of components not tested in combination with these units will void the warranty, may make the equipment in violation of state codes, may create a hazard and may ruin the equipment.

### WARNING - SHOCK HAZARD

To prevent the possibility of severe personal injury or equipment damage due to electrical shock, always be sure the electrical power to the appliance is disconnected during installation.

**CAREFULLY FOLLOW ALL INSTRUCTIONS AND WARNINGS IN THIS BOOKLET TO AVOID DAMAGE TO THE EQUIPMENT, PERSONAL INJURY OR FIRE.**

### NOTE

**The words “Shall” or “Must” indicate a requirement which is essential to satisfactory and safe product performance.**

**The words “Should” or “May” indicate a recommendation which is not essential and not required but which may be useful or helpful.**

## PACKAGE CONTENTS

- 1) Duct Divider Board
- 1) Air Grille Assembly
- 1) Installation Instructions
- 1) Mount Frame
- 1) Insulated Divider Support

- 1) Small Parts Package Consisting Of:
  - 4) Bolts
  - 8) Screws - 3/8" Length
  - 1) Strain Relief
  - 2) Metal Wing Nuts
  - 1) Hand Start Caution Sticker
  - 3) Screws - 3/4" Length

## GENERAL INFORMATION

The flush mount ceiling plenum is designed for application in systems that utilize field fabricated (OEM supplied) cold air ducting. The ducting must be routed through the ceiling cavity (between the interior ceiling and roof). Ducting specifications are given in the section labeled "Supply Ducting and Registers".

This system utilizes a single, non-ducted centrally located return air opening. The return air opening is contained within the ceiling plenum. The ceiling plenum must be located directly below the roof opening used for mounting the roof top unit.

All manual controls have been removed from the ceiling plenum. They have been replaced with control relays. The relays are mounted in the electrical box of the ceiling plenum. The relays contain 12 VDC coils (which may be energized by a wall mounted thermostat), with contacts that control the 115 VAC used to power the roof top unit.

A low voltage controller controls all air conditioning functions. The low voltage controller controls a 12 VDC electrical circuit, which is used to energize the relays in the ceiling plenum. The low voltage controller that RV Products provides for the system may be a combination (Heat/Cool).

These low voltage controllers are capable of operating both the roof top air conditioner and any furnace with a 12 VDC control circuit of 1 amp or less (continuous current).

All infrared control boxes are equipped with a 3.7 amp fuse that will automatically reset to protect the printed circuit board.

All air conditioning equipment is subject to freeze up when evaporator air flow is sufficiently reduced. Ducting of any length creates potential for reduced evaporator air flow and system freeze-up. To protect both the installer and RV Products from conditions that promote reduced air flow and system freeze-up, RV Products has equipped the ceiling plenum compressor control circuit with a low temperature probe. The low temperature probe monitors the temperature of the air conditioner evaporator coil. When the temperature of the evaporator coil drops below 28 degrees F, the switch will open, stopping compressor operation. Compressor operation will resume once the evaporator warms to 55 degrees F.

### IMPORTANT

**The low temperature sensor is part of the ceiling plenum electrical circuit. The probe must be inserted into the evaporator coil of the roof top unit by the installer when bolting the ceiling plenum to the roof top unit.**

## CEILING PLENUM INSTALLATION REQUIREMENT

1. The ceiling plenum must be installed under the roof opening.  
  
The ceiling plenum bolts below the roof top unit. Compression of the framed ceiling cavity between the roof top unit and the ceiling plenum is what holds both components in place.
2. Ceiling cavity depth (the measurement from the ceiling to the roof - maximum 6").
3. Provided with the ceiling plenum is a divider board which is used to separate the conditioned air from the return air supply.
4. The 115 VAC service for the roof top unit must be routed into the ceiling plenum. To prevent wire pinching and to promote ease of installation, allowances must be made for routing the 115 VAC supply wiring into the front of the roof opening.
5. The wirebox has a 9 pin receptacle extending from the front. This mates with the roof unit 115 volt electrical conduit. When making this connection, verify that the plugs are properly aligned and have snapped together securely.
6. The wirebox for the heat/cool units will have a two pin receptacle which mates with the umbilical plug from the heater assembly.
7. LOW VOLTAGE CONTROL WIRING (WALL THERMOSTAT)
  - A. A low voltage terminal strip on the front of the box connects to the low voltage control wires. The wires attach by 1/4" quick connects.
  - B. The low voltage control wiring must be run from the wall thermostat mounting location to the wirebox low voltage terminals. To prevent wire pinching and to promote ease of installation, allowances must be made for routing the low voltage wiring into the front of the opening.

8. **LOW VOLTAGE CONTROL WIRING (INFRARED REMOTE)**

Note: It is recommended to install a 2 amp fuse between the 12 VDC power supply and the control box "R+" (+12 VDC) to protect the control wiring.

A. A low voltage terminal strip on the front of the box connects to the low voltage control wires. The wires attach by 1/4" quick connects.

B. The low voltage power wiring must be run from the power source to the wire box low voltage terminals. To prevent wire pinching and to promote ease of installation, allowances must be made for routing the low voltage wiring into the front of the opening.

C. If a gas heating appliance is to be operated, the low voltage control wiring must be run from the gas heat appliance to the wirebox low voltage terminals. To prevent wire pinching and to promote ease of installation, allowances must be made for routing the low voltage wiring into the front of the opening.

**Standard Control Box**

Plenum Terminal Designation	Thermostat Wire Connection	Function Of Low Voltage Terminal Extending From Ceiling Plenum
B Y OH GI. FREEZE FREEZE	BLUE YELLOW GREEN GRAY WHITE	Completes -12 VDC circuit for all relays Energizes coil on Compressor Relay Energizes coil on High Fan Relay Energizes coil on Low Fan Relay Evaporator Freeze Sensor Connections
W	WHITE	Energizes coil on Heat Relay

"Cool Only" Boxes (left side of table)

"Heat/Cool" Boxes (right side of table)

**Zone Control Box**

Plenum Terminal Designation	Thermostat Wire Connection	Function Of Low Voltage Terminal Extending From Ceiling Plenum
R+	Red	Provides +12 VDC to upper unit control box
Cool Shed (2 terminals)	White Jumper Wire	Removing jumper wire will allow system to be connected to N.C. contacts of a load shed system
Heat Shed (2 terminals)	White Jumper Wire	Removing jumper wire will allow system to be connected to N.C. contacts of a load shed system
Room (2 terminals)	Any	The remote room temperature sensor attaches here*
Freeze (2 terminals)	White	Freeze sensor attaches here
Gen	Any	Allows system to connect to an automatic start generator system
B-	Blue	Provides -12 VDC to upper unit control box
Sig	Purple	Communication line between upper unit control box and thermostat

\* Zone 1 has option of using thermostat as room sensor

## IR CONTROL BOX

Plenum Terminal Designation	Conventional Wire Connection	Function Of Low Voltage Terminal Extending From Ceiling Plenum
R+	Red	Provides +12 VDC to upper unit control box
B-	Blue	Provides -12 VDC to upper unit control box
Freeze (2 terminals)	White	Freeze sensor attaches here
Comm	Telco Cable	Communication line between upper unit control box and receiver assembly
W	White	Enable the gas heating appliance
WR	White/Red	Enable the gas heating appliance**

\*\* Option of using a two wire gas heating appliance and the normally open relay contacts between WR and W if the +12 VDC tab is removed

## CONTROL BOX KITS

**1. 8330-752 12 VDC Controlled, Cool Only**

This kit consists of a control box assembly. The evaporator freeze sensor is shipped in an envelope for installation by quick connects to terminal strip "Freeze".

**2. 9330A755 12 VDC Controlled, Heat/Cool**

This kit consists of a control box assembly. The evaporator freeze sensor is shipped in an envelope for installation by quick connects to terminal strip "Freeze". A heater assembly is also packed with the kit.

**3. 8530-750 24 VAC Controlled, Cool Only**

This kit is similar to the 8330-752 with the exception of a transformer that is attached to the box assembly.

**4. 9530A755 12 VDC Controlled, Heat Pump With Backup Electric Heat**

This kit is similar to the 9330A755 but is wired for the heat pump function.

**5. 9530A751 12 VDC Controlled, Heat Pump**

This kit is the same as the 9530A755 except without the electric heater assembly.

## CONTROL BOX KITS (ZONE)

**1. 8330B751 - 12 VDC Zone Controlled, Cool Only**

This kit consists of a control box assembly. The evaporator freeze sensor is shipped in an envelope for installation by quick connects to terminal strip marked "FREEZE".

**2. 8330C755 - 12 VDC Zone Controlled, Heat/Cool**

This kit consists of a control box assembly and a heater assembly. The evaporator freeze sensor is shipped in an

envelope for installation by quick connects to terminal strip marked "FREEZE".

**3. 8530C751 - 12 VDC Zone Controlled, Heat Pump**

This kit consists of a control box assembly. The evaporator freeze sensor is shipped in an envelope for installation by quick connects to terminal strip marked "FREEZE". Backup electric heat is available as an optional kit (part number 9233-4551).

## CONTROL BOX KITS (INFRARED REMOTE)

### 1. 9330-752 - 12 VDC IR Controlled, Cool Only

This kit consists of a control box assembly, receiver assembly, grille insulation, handheld transmitter, small parts package and an operation manual. The evaporator freeze sensor in the small parts package is to be installed by quick connects to the terminals marked "FREEZE".

### 2. 9330-757 - 12 VDC IR Controlled, Heat/Cool

This kit consists of a control box assembly, receiver assembly, grille insulation, handheld transmitter, small parts package and an operation manual. The evaporator freeze sensor in the

small parts package is to be installed by quick connects to the terminals marked "FREEZE". The electric heater assembly is available as a kit (part number 9233-4551).

### 3. 9530-757 - 12 VDC IR Controlled, Heat Pump

This kit consists of a control box assembly, receiver assembly, grille insulation, handheld transmitter, small parts package and an operation manual. The evaporator freeze sensor in the small parts package is to be installed by quick connects to the terminals marked "FREEZE". Backup electric heater assembly is available as an optional kit (part number 9233-4551).

## WALL THERMOSTATS

1. Locate and install the thermostat per instructions found with the thermostat.
2. For 12 VDC thermostats, it is required that the thermostat 12 volt negative connection be routed directly from the converter or battery. It is highly desirable to provide 12 volt control power from the battery side of the converter. These precautions should prevent control problems.
3. For the 24 VAC thermostat, keep in mind that if the application will involve operation while in motion or

subject to vibration, the electromechanical thermostat must not be used as electromechanical contacts will "chatter" the compressor relay if used in high vibration applications. For applications subject to vibration, an electronic wall thermostat must be used. RV Products part numbers are 8330-3241 or 7330A3441.

4. The sub-base used with heat/cool and heat pump thermostats replaces the mount plate provided with the thermostat. The thermostat body snaps onto the sub-base.

## SUPPLY DUCTING AND REGISTERS

### A. Ducting

1. The field fabricated supply ducting must attach to both sides of the ceiling plenum. A minimum of two ducts are required, with one duct attached to each side of the plenum (See Figure 1).
2. Each duct must have a minimum height of 1 ½", maximum height cannot exceed 4 inches. Total free area inside each duct must be no less than 10 square inches.

Ten (10) square inches of free area per duct is the minimum requirement, larger ducting will improve air flow and system performance.

3. Where ducting secures to the ceiling plenum, maximum width is 8 inches.
4. All field fabricated cold air supply ducting must be insulated and must have a vapor barrier.

### NOTE

To decrease restriction and increase air flow, the ducting should make as few bends and turns as possible. When corners or turns are required, we recommend that you radius the corners to keep air flow at a maximum.

### IMPORTANT

**Insulation reduces cooling loss and helps prevent water staining of the vehicle ceiling due to moisture condensation.**

### B. Registers

Supply (cold air) registers should have a minimum discharge area of 48 square inches per system, or 24 square inches per duct. A minimum of 6 is recommended.

## ROUTING THERMOSTAT WIRING

1. Following the instructions packed with the thermostat, determine a location for thermostat mounting.
2. Following RV Products low voltage wiring specifications and all local and national electrical codes:
  - A. Route the thermostat 12 VDC supply wiring from the power source to the thermostat mounting location.  
  
Two wires are required:  
One supply lead must be +12 VDC and red in color.  
The second supply lead must be -12 VDC and blue in color.
  - B. To protect the wall mount thermostat from over-current damage, a 2 amp fuse has been provided with the thermostat.
  - C. Route the thermostat control wiring from the thermostat mounting location into the front of the ceiling plenum opening.  
  
(4) Four wires are required (5 wires for heat/cool boxes). These wires are as follows:
    - (1) Blue wire for -12 VDC circuit
    - (1) Yellow wire for compressor circuit
    - (1) Green wire for high fan circuit
    - (1) Gray wire for low fan circuit
    - (1) White wire for heat circuit
3. RV Products low voltage wiring specifications:
  - A. All low voltage wiring should be 18 gauge minimum.
  - B. Low voltage wiring must be routed into the front side of the ceiling plenum opening.

## ROUTING THERMOSTAT WIRING (ZONE)

1. Following the instructions packed with the thermostat, determine a location for thermostat mounting.
2. Following RV Products low voltage wiring specifications and all local and national electrical codes:
  - A. Route the thermostat control wiring from the thermostat mounting location into the front of the ceiling plenum opening.  
  
These wires are as follows:
    - (1) Red wire to +12 VDC circuit (R+)
    - (1) Blue wire for -12 VDC circuit (B-)
    - (1) Purple wire to communication signal (Sig)
    - (1) Any color for auto generator start (optional) (Gen)
    - (2) Any color for room temperature sensor (zone 1 optional, required for other zones)
    - (1) For each heating appliance (Up to 4)
    - (2) Any color for cool load shed (optional)
    - (2) Any color for heat load shed (optional)
  - B. See Figure 5 for wiring requirements for multiple zones.
3. RV Products low voltage wiring specifications:
  - A. All low voltage wiring should be no smaller than 18 gauge.
  - B. Low voltage wiring must be routed into the front side of the ceiling plenum opening.
  - C. Low voltage wiring should not be routed with high voltage wiring.
  - D. If low voltage and high voltage wires must cross, they should do so at right angles from one another.

## ROUTING IR WIRING

1. Following RV Products low voltage wiring specifications and all local and national electrical codes:
  - A. Route the 12 VDC supply wiring from the power source to the control box mounting location in the front of the ceiling plenum opening. Two wires are required:
    - (1) Red wire to +12 VDC circuit (R+)
    - (1) Blue wire for -12 VDC circuit (B-)
  - B. Route the control wiring from the gas heating appliance to the control box mounting location in the front of the ceiling plenum opening. This is not required for the units that do not have a gas heating appliance.

Single wire gas heat appliance has a +12 VDC signal and only one wire is required:

    - (1) White wire for the gas heating appliance (W)

Two wire gas heat appliance will use the N.O. contacts of the heat relay if the +12 V tab is removed. Two wires are required:

    - (1) White wire for the gas heating appliance (W)
    - (1) White/Red wire for the gas heating appliance (WR)
2. RV Products low voltage wiring specifications:
  - A. All low voltage wiring should be no smaller than 18 gauge.
  - B. Low voltage wiring must be routed into the front side of the ceiling plenum opening.
  - C. Low voltage wiring should not be routed with high voltage wiring.
  - D. If low voltage and high voltage wires must cross, they should do so at right angles from one another.
  - E. Insure that wires cannot contact screws or sharp edges in the wire race ways.
  - F. If stapling the wire bundle during the routing process, be careful not to pierce the wire insulation.

## ROUTING 115 VAC WIRING

Following RV Products high voltage wiring specifications and all local and national electrical codes, route the roof top unit 115 VAC supply wiring from its power source and into the front of the roof top opening. Allow approximately 12" of the wiring into the opening.

### High Voltage Wiring Specifications

1. U.L. approval requires the power supply to be copper conductors only with minimum #12 AWG.

2. To prevent voltage drops greater than 10% during starting, adhere to the following guideline:

For lengths greater than 50', use #10 AWG.

Circuit Protection - Refer to upper unit nameplate.



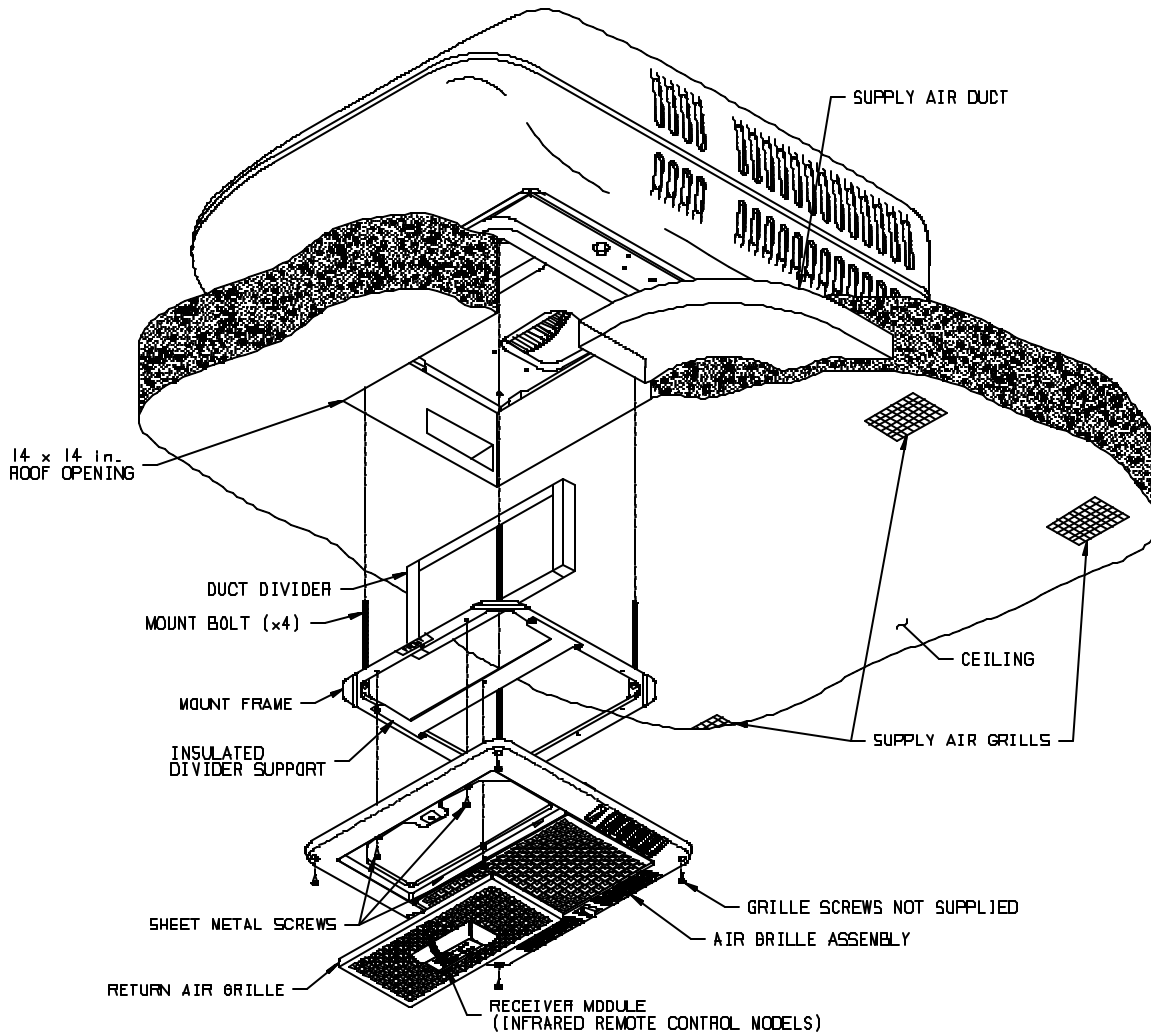

FIGURE 1

## CEILING PLENUM MOUNTING

### A. Installing Unit (Refer to Figure 1)

1. Place the air conditioner over the roof opening.
2. Position the mount frame into the ceiling opening (See Figure 1).
3. Using the four bolts provided, secure the mount frame to the roof top unit. The four mounting bolts are to be applied up through the bottom of the mount frame and into the bottom of the roof top unit (See Figure 1). Tighten each bolt until the indicators of the gasket are at roof level.
4. Route the conduit into the return opening.

### B. Installing Divider Board (Refer to Figure 1)

1. Measure the distance between the ceiling and the upper unit basepan, add  $\frac{1}{2}$ " to this measurement and cut the duct divider to this height if necessary. **ALWAYS CUT OFF THE BOTTOM EDGE (THE EDGE WITHOUT FOAM STRIP).**
2. Carefully wedge this divider between the walls of the roof opening and up against the upper unit basepan with the silver side facing forward.
3. Align the divider support plate under the duct divider. Attach to mount frame with four short screws found in the small parts package (See Figure 1).

## INSTALLING THE CONTROL BOX

1. Remove the control box assembly cover which is held by two sheet metal screws. Feed the field lead wires and ground through the strain relief found with the control box.
2. Attach black supply conductor to black "pigtail" lead, white to white, and ground to green with wire nuts provided in control box kit.
3. Insure that no bare wires can come into contact with live electrical parts and that wires cannot be pinched between the control box sides and lid. Insert the strain relief into the control box entry hole to secure the field wiring. Reinstall the control box lid.
4. Attach the thermostat wires to the control box per illustrations below:

A. Control Box 8330-752

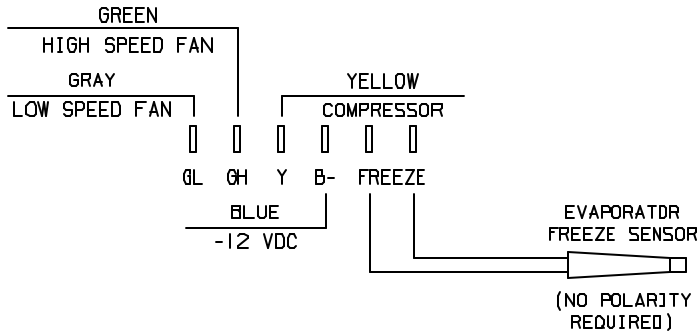

B. Control Box 9330A755, 9530A751 & 9530A755

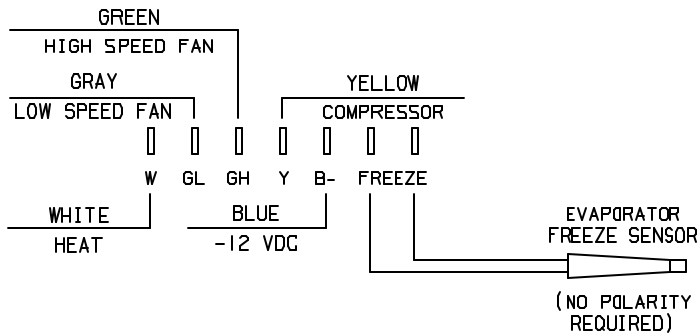

C. Control Box 8530-750

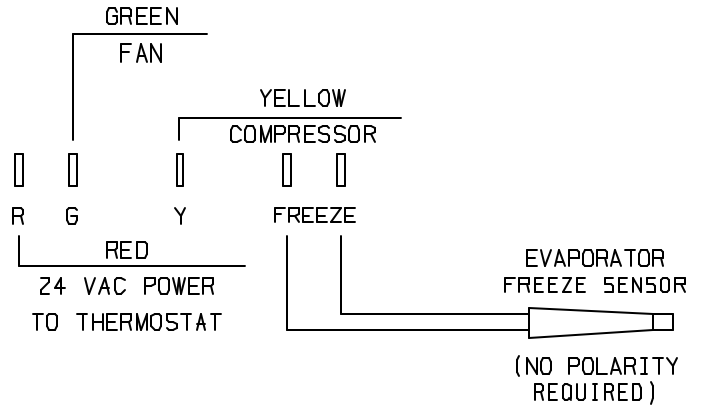

5. Connect the roof unit 115 volt electrical conduit to the wirebox 9 pin receptacle and verify that the plugs are properly aligned and have snapped together securely.
6. Locate the two machine screws inside the evaporator cover of the upper unit. Align the control box over the screws and use the wing nuts supplied with the control box to secure it to the upper unit enclosure.
7. Insert the evaporator freeze sensor between evaporator fins near the bottom center of the evaporator and between the bottom two tubes (See Figure 2). Insert straight in until contacting the staggered tube directly in back of the insertion point. When contact has been made, elevate the exposed end of the sensor approximately 45 degrees, then continue insertion at a 45 degree angle until the sensor is completely embedded into the evaporator.

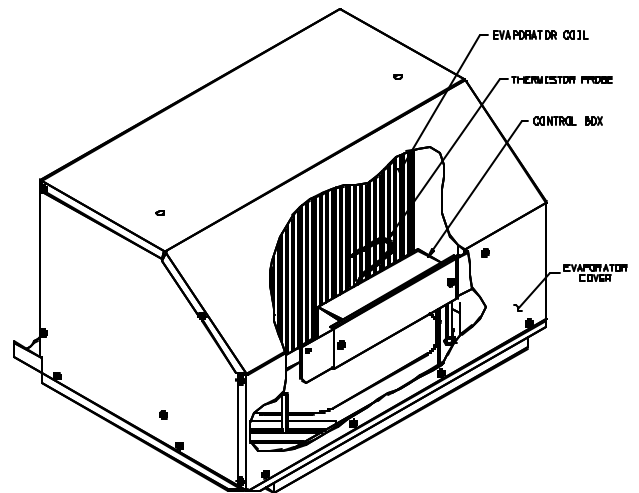

FIGURE 2

## INSTALLING THE CONTROL BOX (ZONE)

All control boxes install by one of two methods.

1. Remove the control box assembly's cover which is held by two sheet metal screws.
2. Set the "zone" jumper to the proper zone position for the particular position the air conditioner or heat pump will be in the coach (**Refer to Figure 3- Zone 1 is shown**). Zones should be numbered from the front of the back of the coach with Zone 1 in front.
3. Set the "HP"/"NON HP" jumper to "HP" if the unit is a heat pump or to "NON HP" if the unit is not a heat pump (**Refer to Figure 3- Non HP is shown**).
4. Feed the field lead wires and ground through the strain relief found with the control box then through the 7/8" hole in the side of the box.

5. Wire nut the black 12-gauge field power conductor to the stripped black 12-gauge wire in the control box.
6. Wire nut the white 12-gauge field power conductor to the stripped white 12-gauge wire in the control box.
7. Wire nut the ground field power conductor to the stripped green ground wire in the control box.
8. Insure that no bare wires can come into contact with live electrical parts and that wire cannot be pinched between the control box sides and lid. Insert the strain relief into the control box entry hole to secure the field wiring. Reinstall the control box lid.
9. Mount control box in upper unit return air compartment.

Attach the thermostat wires to Zone 1 control box per the illustration below (Refer to Figure 4):

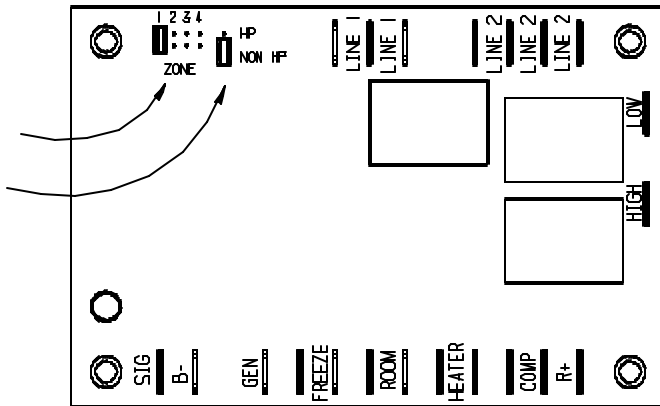

FIGURE 3

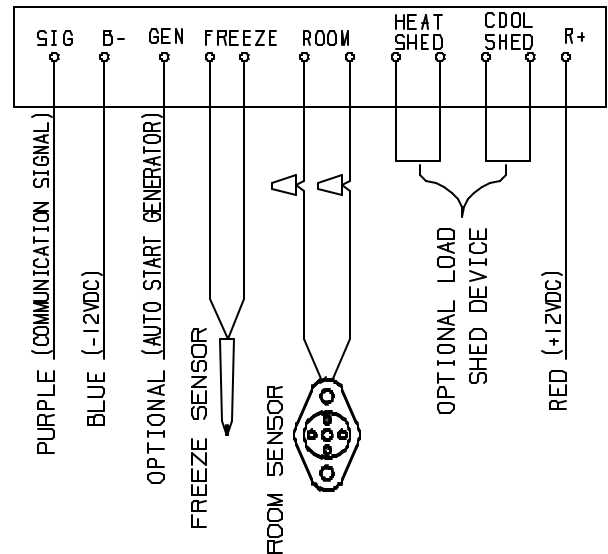
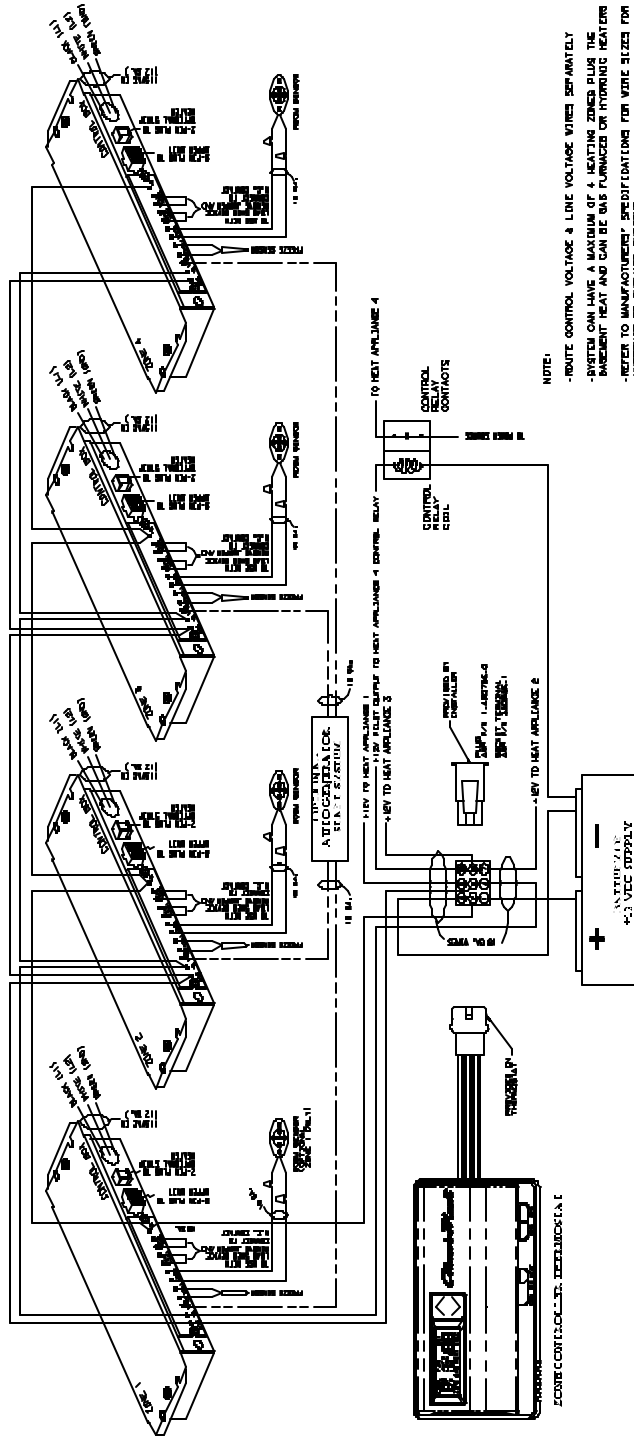

FIGURE 4



Note: The Zone System is shown with the maximum heating and cooling appliance connections.

FIGURE 5

Zone 2 is wired in by jumpering from SIG, B- and R+ on Zone 1 box to Zone 2 box. Zone 3 is wired in by jumpering from SIG, B- and R+ on Zone 2 box to Zone 3 box. Zone 4 is wired in by jumpering from SIG, B- and R+ on Zone 3 box to Zone 4 box (See Figure 5).

Connect the roof unit 115 volt electrical conduit to the wirebox 9 pin receptacle and verify that the plugs are properly aligned and have snapped together securely.

The control box will be mounted by first removing the rubber wel-nuts (if supplied with the control box) and discarding the wing bolts. Position the control box over the screws and use the rubber wel-nuts (or wing nuts if supplied) to fasten the control box to the upper unit enclosure.

Insert the evaporator freeze sensor between evaporator fins near the bottom center of the evaporator and between the bottom two tubes (See Figure 2). Insert straight in until contacting the staggered tube directly in back of the insertion point. When contact has been made, elevate the exposed end of the sensor approximately 45 degrees, then continue insertion at a 45 degree angle until the sensor is completely embedded into the evaporator.

Complying with the warnings listed below, connect the 115 VAC supply wiring to its power source. Be sure all power remains off until beginning checkout procedure.

**DANGER**

**TO PREVENT THE POSSIBILITY OF SHOCK INJURY FROM APPLIANCE OPERATION:**

**THE WHITE WIRE MUST BE CONNECTED TO NEUTRAL IN THE SERVICE BOX ENTRANCE AND THE MECHANICAL GROUND MUST BE CONNECTED TO A GROUNDING LUG IN THE SERVICE BOX OR THE MOTOR GENERATOR COMPARTMENT.**

**INSTALLING THE CONTROL BOX (IR)**

1. Remove the control box assembly's cover.
2. Optional to remove the "FURNACE" tab if no gas heating appliance is to be used. This will disable any future use of a gas heating appliance.
3. Remove the "+12V" tab if a two wire gas heating appliance is to be used.
4. Insert the strain relief into the 7/8" entry hole in the side of the control box. Feed the field wires and ground through the strain relief.
5. Wire nut the black 12-gauge field power conductor to the stripped black 12-gauge wire in the control box.
6. Wire nut the white 12-gauge field power conductor to the stripped white 12-gauge wire in the control box.
7. Wire nut the ground field power conductor to the stripped green ground wire in the control box.
8. Insure that no bare wires can come into contact with live electrical parts and that wires cannot be pinched between the control box sides and lid. Secure the field wiring in the strain relief. Reinstall the control box lid.

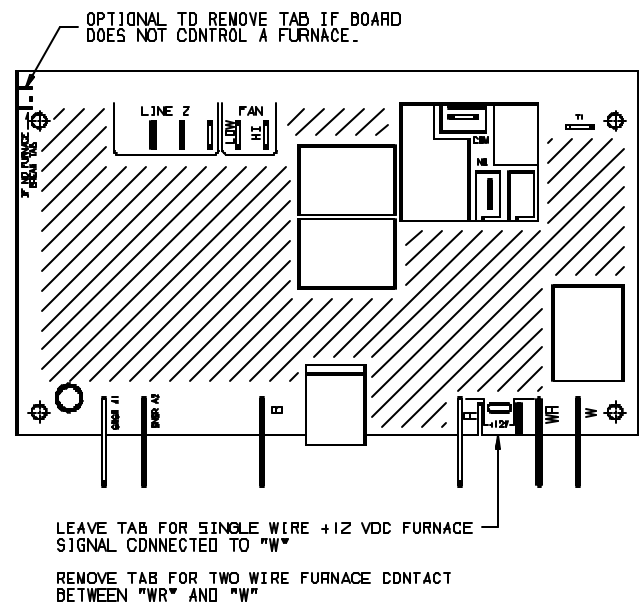

**FIGURE 6**

9. Attach the low voltage control wires to the control box per the illustration below:

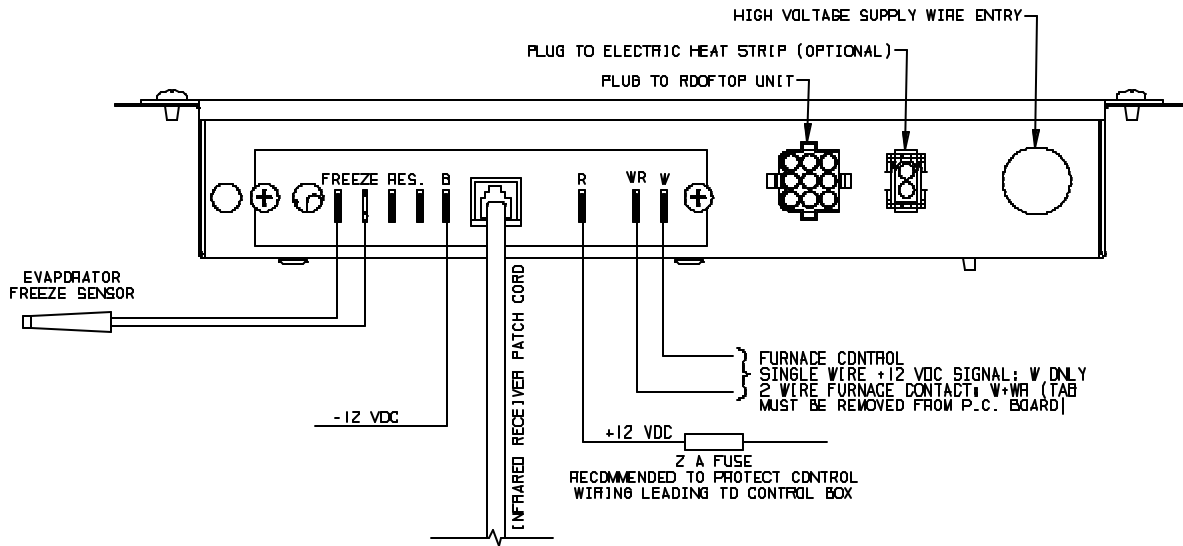

FIGURE 7

- Note: Receiver patch cord will be connected to the receiver assembly when the air grille assembly is installed.
9. Connect the roof unit 115 volt electrical conduit to the wirebox 9 pin receptacle and verify that the plugs are properly aligned and have snapped together securely.
10. Locate the two machine screws inside the evaporator cover of the upper unit. Align the control box over the screws and use the wing nuts supplied with the control box to secure it to the upper unit enclosure.
11. Insert the evaporator freeze sensor between the evaporator fins near the bottom center of the evaporator and between the bottom two tubes (See Figure 2). Insert straight in until contacting the staggered tube directly in back of the insertion point. When contact has been made, elevate the exposed end of the sensor approximately 45 degrees, then continue insertion at a 45 degree angle until the sensor is completely embedded into the evaporator. Then connect the sensor to the two terminals marked "FREEZE".

12. Complying with the warnings listed below, connect the 115 VAC supply wiring to its power source. Be sure all power remains off until beginning the checkout procedure.

**DANGER**

**TO PREVENT THE POSSIBILITY OF SHOCK INJURY FROM APPLIANCE OPERATION:**

**THE WHITE WIRE MUST BE CONNECTED TO NEUTRAL IN THE SERVICE BOX ENTRANCE AND THE MECHANICAL GROUND MUST BE CONNECTED TO A GROUNDING LUG IN THE SERVICE BOX OR THE MOTOR GENERATOR COMPARTMENT.**

## INSTALLING THE HEATER ASSEMBLY

1. The heater assembly found with the 9330A755, 9530A755 or 8330B755 control box kits can now be installed. The backup electric heater assembly is optional for control box kits 8530B751, 9330-757, 9530A751 or 9530-757. The backup electric heater assembly is available as a kit (part number 9233-4551).
2. Position the heater assembly into the return air opening as shown in Figure 9. Insure that the set screw is retracted sufficiently to allow installation over the basepan extrusion.
3. The heater bracket **must be installed between the basepan and the plastic drain pan.** See Figure 8.
4. Tighten set screw to secure the assembly so as to prevent movement.
5. Insert the two-pin connector of the heater umbilical into the receptacle on the control box. Insure that the connector snap-locks into position.

**TIE ALL WIRING TO INSURE NO CONTACT WITH THE HEATER OR ANY SHARP EDGES. KEEP IN MIND THAT HIGH VELOCITY AIR WILL BE ENCOUNTERED IN THIS AREA.**

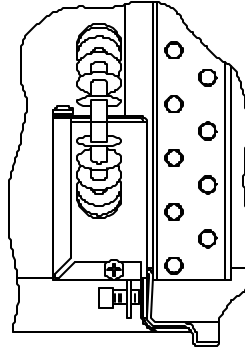

FIGURE 8

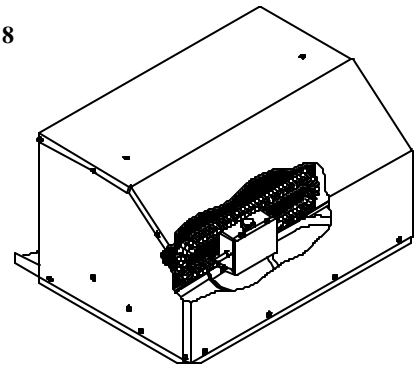

FIGURE 9

## INSTALL AIR GRILLE ASSEMBLY

1. Temporarily remove the air grille assembly filter door. A quarter-turn of the fastener will disengage the door. Attach the air grille frame to the mount frame with 3 screws as shown in Figure 1 - use 3/4" screws. Adjust as desired to insure that all foam parts are within the grille perimeter, and secure the corners of the grille to the ceiling. These 4 corner screws are not provided. Check all fits to insure that a reasonably air tight seal exists to separate unit supply air from unit return air.
2. If an IR CONTROL KIT is used, the receiver assembly will need to be installed.
  - A. Remove the filter and locate the receiver assembly in the face of the filter door grille. Then secure it to the door with the two screws and washers provided in the small parts package of the control kit.
  - B. Install grille insulation over the location of the receiver assembly while locating the hole for the receiver patch cord.
  - C. Re-install the filter and make a small cross-cut at the location of the communication plug. Then connect the communication wire (Patch Cord) from the control box to the receiver.
3. Reinstall the filter door.

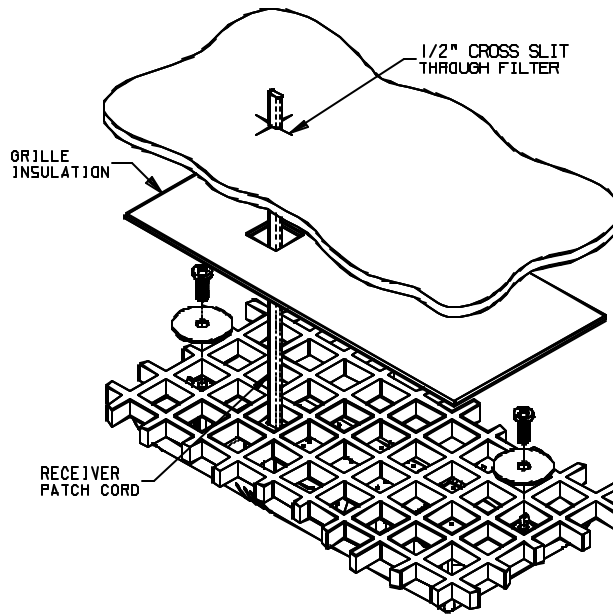

FIGURE 10

## MOUNTING AND CONFIGURING THE HANDHELD TRANSMITTER

1. To attach the handheld transmitter on a wall, separate the transmitter from the wall mount bracket. Then attach the wall mount bracket to the wall at the desired mounting location using the two screws provided.
2. To configure the handheld transmitter, remove the battery compartment cover and batteries. The transmitter will come with the dip switches J1 and J4 in the "OFF" position. It is optional to move the dip switch J2 to the "OFF" position for those applications without a gas appliance installed. It is required to move the dip switch J4 to the "ON" position for those applications with an electric heat appliance installed. Then reinstall the batteries and cover.
3. Place the transmitter in the wall mount bracket and installation is now complete.

conditions such as: direct sunlight, windows, outside doors, supply registers or heat producing appliances (television, radio, wall lamp, etc.).

Note: The temperature sensor in the transmitter can be affected by the surrounding

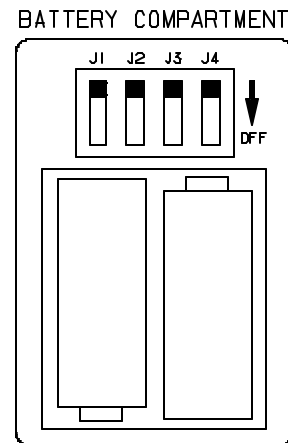

FIGURE 11

RV Products  
 A Division of Airxcel, Inc.  
 P.O. Box 4020  
 Wichita, KS 67204

Web: [www.rvcomfort.com](http://www.rvcomfort.com)  
 Support: [www.rvsupport@airxcel.com](mailto:www.rvsupport@airxcel.com)  
 Sales: [www.rvpsales@airxcel.com](mailto:www.rvpsales@airxcel.com)