



# Installation Instructions

## TC9402 Bracket Kit

Serial No.

The TC35270 steering control is recommended for use with this bracket kit.

**Do not install TruCenter anchor bracket to driver's side.**

1. Set front wheels of vehicle in straight ahead position.
2. Remove nuts from passenger's side rear spring U-bolt.
3. Install Item 2 on to axle and reinstall the existing washers and nuts. Tighten to manufacturer's specs.
4. Install Item 3 on tie rod using Items 4 and 7, according to drawing on page 2. **DO NOT TIGHTEN.** *Item 3 may be rotated or flipped to insure steering control (Item 1) remains parallel to the ground.*
5. Install solenoid end of Item 1 to top of Anchor Bracket (Item 2) with Items 5, 6, 8 and 9, according to drawing on page 2.
6. Install small end of TruCenter unit (Item 1) to top of Tie Rod Bracket with Items 5, 6, 8 and 9, see drawing on page 2. Allow enough slack for the Tie Rod Bracket (Item 3) to rotate for alignment to the tie rod. **DO NOT FULLY TIGHTEN.**
7. Rotate Tie Rod Bracket (Item 3) around tie rod, so that the small diameter end of the TruCenter is approximately 1/2" lower than the large end of the unit.
8. Tighten Items 5, 6, 8 and 9 on Anchor Bracket (Item 2) to 180-200 ft/lbs of torque.
9. Tighten Items 4 and 7 on the Tie Rod Bracket (Item 3) to 25-35 ft/lbs of torque, while maintaining an even amount of threads extending past each nut.
10. Tighten Items 5, 6, 8, and 9 on the Tie Rod Bracket (Item 3) to 180-200 ft/lbs of torque.

*Check to be sure installed unit clears all other parts of vehicle by turning steering wheel to both extreme right and left positions. If unit scrapes or binds at any point, make necessary corrections by rotating unit on tie rod to obtain necessary clearance.*

11. *Install TruCenter Steering Control wiring according to instructions included in its package.*

**12. DEALER OR INSTALLER: BE CERTAIN USER RECEIVES INSTRUCTION SHEET.**

*Insure that you use the proper TruCenter steering control unit for your application. Using too strong or too weak of a steering control may result in improper or undesirable handling.*

#### **Product Safety Policy Statement**

*It is, and shall continue to be, a primary objective of Blue Ox Towing Products to provide customers with safe and reliable products. Blue Ox will, and has, established safety procedures in product design, manufacture, promotion and sales; and will coordinate efforts to promote customer safety to the greatest extent possible. Each department has primary responsibility for the promotion of safety under the guidelines of the Product Safety Committee.*

© 2003 Blue Ox  
One Mill Road, Industrial Park  
Pender, Nebraska 68047  
Phone 402-385-3051  
Toll Free 888-425-5382  
Fax 402-385-3360  
www.blueox.us

## Tools Required

9/16" Socket

1 1/8" Socket

1 1/8" Wrench

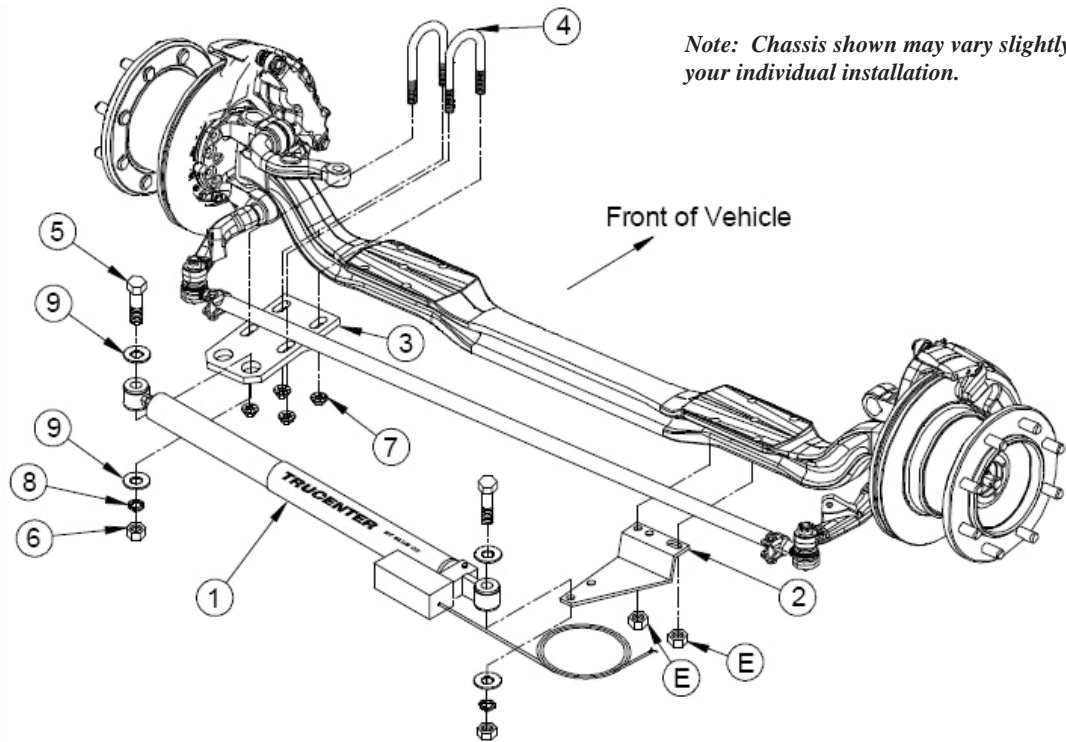

*Note: Chassis shown may vary slightly from your individual installation.*

## Parts List

Ref. No.	Qty.	Part No.	Description
1*	1	TC35270	TruCenter, Steering Control
2	1	101-6419	Plate, Anchor Bracket
3	1	102-6344	Bracket, Tie Rod
4	2	201-0720	U-Bolt, 3/8-16 x 2.00, Grd 5, ZP
5*	2	201-0780	Bolt, 3/4-10 X 3 1/2, 1.59In Flange
6*	2	202-0180	Nut, 3/4-10, 1.59 Flange, Grd. 8, ZP
7	4	202-0174	3/8-16, Cent. Dimp. Flng, Nut, ZP
8*	2	203-0014	3/4 Lock Washer, ZP
9*	8	203-0007	3/4 Flat Washer, ZP
E	2		Existing Hardware

\*items are purchased separately with the TC35270 steering control unit.

**IMPORTANT:** Use only genuine factory replacement parts on your bracket kit. Do not substitute homemade or nontypical parts. If a bolt is lost or in need of replacement, for your safety and the preservation of your bracket kit, be sure to use a replacement bolt of the same grade. Repair parts may be ordered through your nearest **Blue Ox** dealer or distributor.



© 2003 Blue Ox  
 One Mill Road, Industrial Park  
 Pender, Nebraska 68047  
 Phone 402-385-3051  
 Toll Free 888-425-5282  
 Fax 402-385-3360  
 www.blueox.us