



OWNER'S MANUAL



The following instructions provide valuable information regarding the function and proper use of the SuperGlide Fifth Wheel Towing System.

YOU MUST COMPLETELY READ THE INSTRUCTIONS WITHIN THIS MANUAL PRIOR TO OPERATING THE HITCH TO PREVENT UNNECESSARY DAMAGE TO THE HITCH, VEHICLE, OR TRAILER.

For more information, please call PullRite at (800) 443-2307.

TABLE OF CONTENTS

HOW DOES THE SUPERGLIDE WORK?	4
CAUTION	5
TESTING CLEARANCE	5
LUBRICATION.....	6
WAY TUBES.....	6
5TH WHEEL PLATE	7
KING PIN, PIVOT BOLT & ROLLER	7
REQUIRED MAINTENANCE	7
FIFTH WHEEL PLATE OPERATION.....	8
HITCHING	9
SAFETY CHECKS.....	10
UNHITCHING	10
ADJUSTING THE TURNTABLE CAM ARM ASSEMBLY	11
CHALLENGE VS. SOLUTION.....	12
FREQUENTLY ASKED QUESTIONS	13
#3600 PARTS SECTION.....	16
ILLUSTRATION — #3600 EXPLODED VIEW	16
#3600 PARTS LIST	17
SLIP PLATE INSTRUCTIONS.....	I
#3336 CONVERSION ADAPTER.....	III
5 YR. WARRANTY	IV
PRODUCT REGISTRATION	V

HOW DOES THE SUPERGLIDE WORK?

The SuperGlide is an automatically sliding 5th wheel hitch based on a mechanical, cam action. Other sliding hitches on the market today require you to get in and out of the vehicle multiple times before and after a turn, throwing levers to allow it to move back and forth. The cam action of the SuperGlide hitch is truly automatic. When installed in your short bed truck and used in conjunction with our Capture Plate, the SuperGlide “glides” along the Way Tubes with ease, making turns automatically, without you having to ever get out of your vehicle. Here’s how it works:

Equipping your trailer’s king pin box with one of our Capture Plates (required for the hitch to function properly and sold separately), restricts the king pin on your trailer from turning in the 5th wheel plate on the SuperGlide. Once the truck begins to make a turn, the “captured” 5th wheel plate forces the large roller of the turntable cam arm assembly to rotate and roll along the path of the cam slot to begin the turn. This action pulls the plate and turntable assembly, with trailer in tow, away from the cab of your truck. The more you turn, the more it moves back.

It is important to note that the width of the trailer and the location of the king pin in relation to the “nose”, or leading edge of the trailer, is *critical* in determining if your truck and trailer are compatible to be used with a SuperGlide. Short bed trucks have only so much room from cab-to-axle; if your king pin is located too far under the nose of the trailer, the cam action of the SuperGlide may not move the trailer back fast enough to allow the necessary clearance.

Another important point in the use and maintenance of your SuperGlide is the need to lubricate the moving parts. Hitches manufactured prior to November 2009 require a heavier application of a lubricant to operate the hitch properly because of the metal-to-metal interaction of the Turntable Cam Arm Assembly and the Way Tubes. If proper lubrication is not present, the forces involved cause the metal surfaces to bond. This condition is known as galling.

Galling is a condition whereby excessive friction occurs due to insufficient lubrication, resulting in localized, cold welding of metals together. Most often, galling occurs when the Turntable bonds to the Way Tubes, causing the cam action to halt. The power of the truck and leverage of the trailer continuing to move in the turn, will cause the deformation of the hitch parts.

BEFORE OPERATING YOUR SUPERGLIDE HITCH, YOU MUST READ THE “LUBRICATION” SECTION ON PAGE PAGE 6. IF YOU HAVE ANY QUESTIONS REGARDING LUBRICATION OR HOW THE SUPERGLIDE FUNCTIONS, PLEASE CONTACT OUR CUSTOMER SERVICE DEPARTMENT AT (800) 443-2307 BEFORE USING YOUR SUPERGLIDE.

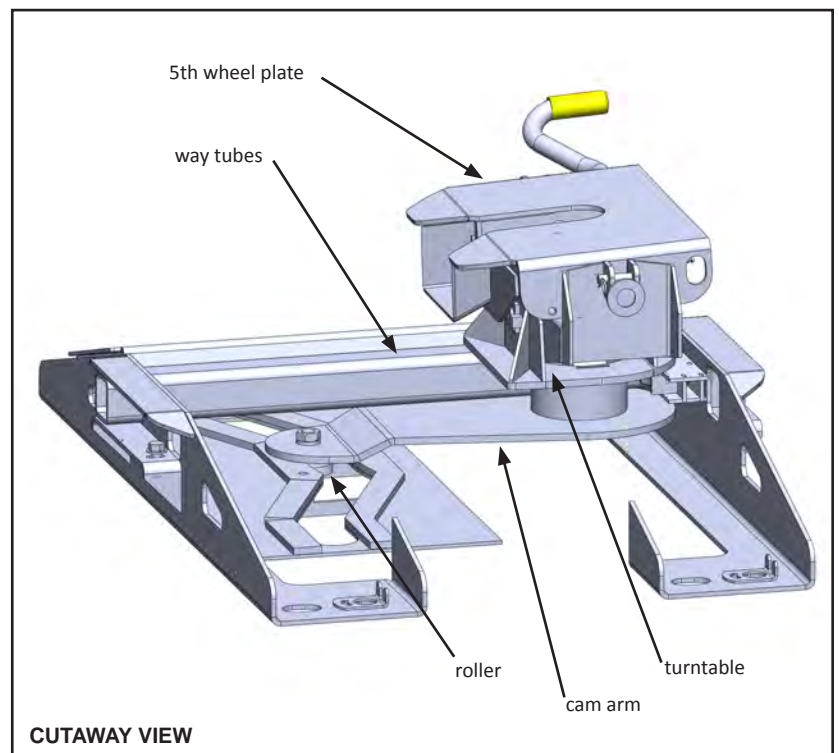
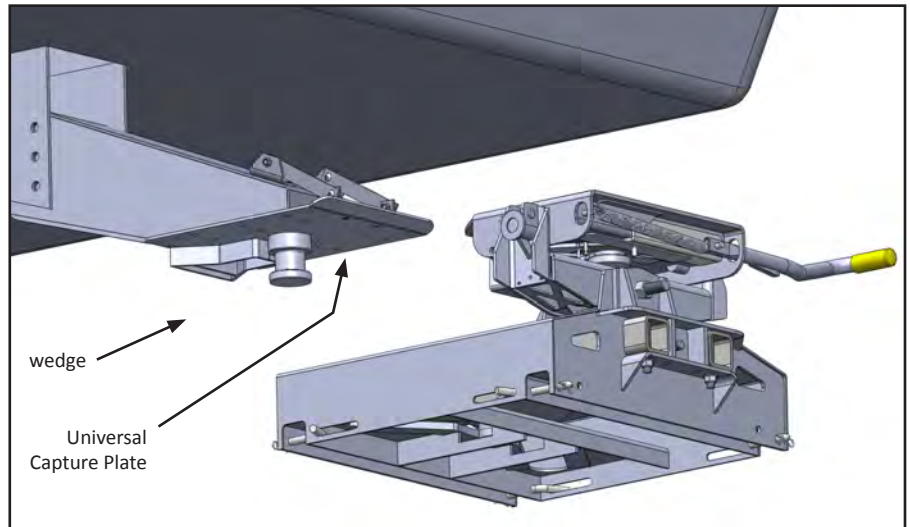

CAUTION

- The width of the trailer and the location of the king pin in relation to the “nose” (Dimension A), or leading edge of the trailer, is *critical* in determining if your truck and trailer are compatible to be used with a SuperGlide. If your king pin is located too far under the nose of the trailer, the cam action of the SuperGlide may not move the trailer back fast enough to allow the necessary clearance. Call PullRite Customer Service at (800) 443-2307 with trailer width, make and year of truck, and the distance of the king pin from the leading edge of the trailer (Dimension A).
- Using a trailer that has a long rear slope to the king pin box hangar, “B”, may cause damage to the king pin box or the inside edge of the truck bed. Dimension “B” must be less than one half the width of the inside top edges of the bed during turns for proper clearance.
- The SuperGlide hitch is equipped with a side-to-side pivot feature. There should be a minimum of 6” between the truck bed rails and the under side of the trailer for side tilt clearance. It is the customers responsibility to adjust the trailer king pin box for the appropriate amount of clearance depending on the terrain being traveled (example: some State Parks are sloped and unpaved; some driveways are steeply angled). If bed covers are added, care must be taken to allow for additional clearance.
- The SuperGlide hitch is designed to allow you to make a 90 degree turn. Please use extreme caution when turning this far. In addition to putting stress on the wheels and axles of your trailer, if you make a turn greater than 90 degrees the trailer will contact your truck and you WILL damage various parts of the hitch which will NOT be covered under the manufacturers warranty.
- Position your brake cable so the slack in the cable will not be allowed to catch on the hitch during turns or lodge in the cam mechanism. Failure to modify its length may cause the cable to catch on protruding parts of the hitch which could activate the trailer brake, causing damage to the truck, trailer or hitch. Resulting damages will not be covered by warranty.
- Position or coil any slack in your 7-way electrical cable out of the way of your moving hitch. It is preferred that the plug and cabling remain isolated rearward of the hitch (nearest the tailgate) to prevent damage. Make slow test turns while observing the 7-way cable until you are satisfied that it will not become caught in the hitch mechanism.
- Anything carried in the bed of your truck during towing will need to be well secured. Remove any foreign debris that might move around in the bed and contact the hitch. ***This will help to ensure that nothing will get caught in or jam the movement of the cam which can cause damage to the hitch.***

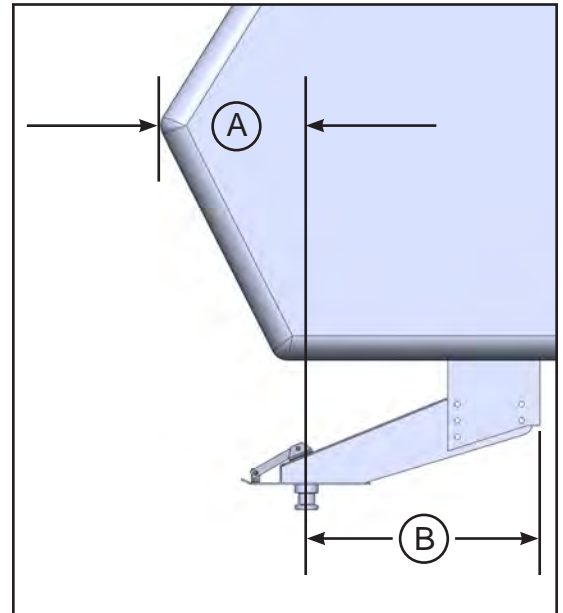

TESTING CLEARANCE

When you are assured your trailer is safely hooked up, pull forward and slowly start to turn. Make sure that someone is outside watching the distance between the cab and the trailer. The distance between the cab and trailer should be greater than two inches at all points of the turn. Specifically watch the distance when the corner of the trailer is closest to the cab and also when nearing a 90 degree turn. The minimum two inches of clearance is needed for normal driving conditions. The practice of testing clearance will let you know how much clearance you actually have should you encounter adverse road conditions.

Example: It is possible for the trailer to hit the cab when turning through a dip where the corner of the trailer is closest to the cab or when nearing a 90 degree turn.

LUBRICATION

DO NOT OPERATE HITCH UNTIL YOU READ THIS SECTION!

The SuperGlide hitch was designed to “glide” along two metal tubes, called the Way Tubes. Since it’s release in 1998, we have made several advancements to the strength, durability and design of these components. This section on lubrication spans several releases and design changes. It is imperative that you read each section and assess which SuperGlide hitch you purchased, and how to care for it. There have been two major lubrication changes to the 24K SuperGlide hitch:

1. Prior to April 2008, Way Tubes were assembled with either a conventional, quality grade grease or none at all.
2. In April 2008, we started coating the Way Tubes with a graphite-based spray lubricant called SlipPlate™.

Depending on when your hitch was manufactured, the Way Tubes of your new SuperGlide hitch will meet one of the previous criteria. Each application listed requires some level of maintenance, so it is important that you read the following instructions carefully, choosing which application you have, and adhering to the lubrication instructions as follows:

WAY TUBES

It is good practice, to check the lubrication on your Way Tubes during stops, checking for any areas that may need additional lubrication.

Failure to properly lubricate the Way Tubes, as directed in this section, will eventually cause galling between the metals of the Way Tubes and Cam Arm Assembly, which will result in hitch failure. Destruction of various hitch parts is also likely, as well as truck and/or trailer damage, and will not be covered under the Manufacturer’s Warranty.

Conventional Grease (prior to April 2008)

If your hitch was manufactured *prior* to December 2006, and grease is present, you must clean off all factory grease from the Way Tubes (WD-40 works well as a cleaning agent) and reapply a liberal coat of either a medium duty grease or SlipPlate™ graphite lubricant spray. You can elect to use either a conventional, quality grade grease or SlipPlate™.

When using SlipPlate™ as your lubricant of choice, it is important to note that the Way Tubes that have been previously greased with another lubricant, and it is imperative that all grease residue has been removed, otherwise, the SlipPlate™ will not adhere to the metal (hitches manufactured *after* December 2006, were not shipped with factory grease on the Way Tubes). See the following section for more information on applying SlipPlate™.

If you choose to use conventional grease, the Ways Tubes must be lubricated liberally each day of use. It is essential that you use a quality grade medium duty grease on the top and inward-facing sides of Way Tubes. WD-40 or silicone spray is NOT sufficient. Clean the old grease off as needed and reapply. Move the 5th wheel assembly back and forth during lubrication to spread the lubrication along the ways. This will also lubricate the turntable shaft. When your trip is completed, be sure there is still a coating of grease on the Ways to protect them while the hitch is not in use. Failure to properly lubricate the Way Tubes will eventually cause galling between the metals of the Way Tubes and the Cam Arm Assembly which will result in the failure of the hitch to work properly. Destruction of some of the various hitch parts is also likely and will not be covered under the Manufacturer’s Warranty.

LUBRICATION

DO NOT OPERATE HITCH UNTIL YOU READ THIS SECTION!

SlipPlate™ (April 2008 - October 2009)

Hitches shipped after April 2008, have already been coated with SlipPlate™ and will appear dark gray in color. This initial coating will give you enough lubrication for a short trip, plan on inspecting the Way Tubes after a short time so you can become visually familiar with the characteristics of how the SlipPlate™ is wearing. During trailering, there will be areas on the Way Tubes that show more wear from the Turntable/Cam Arm sliding over the top and inside faces of the Way Tubes. Reapply a light coat of SlipPlate™ on those worn areas each time you trailer.

Every few hundred miles, you should apply a coating of SlipPlate™ over the full length of the Way Tubes, both on the top and inward facing sides. The frequency of coating depends on personal trailering habits, trailer weight and road conditions such as the number of curves and turns experienced during a period of trailering.

5TH WHEEL PLATE

The plate and it's moving parts should be lubricated with a light lubricant such as WD-40 or 3-in-1 oil, before each trip or as needed. Be sure the plate is free of dirt and old oil buildup. Pull the Release Handle repeatedly so that the lubricant will spread among the moving parts that may not have otherwise been covered sufficiently.

KING PIN, PIVOT BOLT & ROLLER

Be sure the trailer's king pin is clean and free from rust. A light coating of WD-40 or other similar lubricant should be used on the king pin. Inspect and lubricate the Pivot Bolt monthly with axle grease when heavily used, or annually with light use. To remove the pivot bolt for lubrication:

1. Remove the Fifth Wheel Plate {A} from the Rocker Arm.
2. Remove the hex nut {C5} and lockwasher {C6} from the Rocker Arm Pivot Bolt {C4}.
3. Place downward force, compressing the Rocker Arm Spring, enabling the Pivot Bolt to be removed.
4. Lube the Pivot Bolt generously with a quality axle grease and reinstall. Tighten the Pivot Bolt to the point where there is resistance when you move the Rocker Arm side-to-side.
5. Inspect the Roller to ensure it is securely fastened.

REQUIRED MAINTENANCE

Whether you are using conventional grease or SlipPlate™ graphite spray, the inward facing sides and tops of the Way Tubes must be thoroughly cleaned off and removed of lubricant buildup; including any other areas you have lubricated prior.

Inspect all mounting bracket and hitch hardware, that it is securely fastened. The fifth Wheel Plate should be removed and inspected, checking all moving parts for wear—clean as directed above. Inspect all mounting bolts, and mounting post holders periodically for tightness and general condition. When storing the SuperGlide hitch, you should be sure that the 5th Wheel Plate and Way Tubes are covered with the appropriate lubricant as directed above (conventional grease or SlipPlate™). Cover the entire assembly to prevent accumulation of dirt, grime, or rust. We suggest purchasing a SuperGlide hitch cover (Part# 3334) directly from PullRite to protect your investment. Call (800) 443-2307 to order.

FIFTH WHEEL PLATE OPERATION

A better understanding of the plates locking and un-locking operation can be obtained by viewing the working parts from the underside of the plate. The 5th Wheel Plate {A} can be removed and turned over to view the workings of the mechanism.

1. To open the locking mechanism, lift and pull the Release Handle out until the Lock Catch engages the Lock Jaw Assembly. (see below).
2. As the trailer king pin moves into the plate, it will contact the Lock Lever, forcing the Lock Catch to disengage the Lock Jaw Assembly, allowing the Main Spring to close the Lock Jaw Assembly behind the King Pin. The King Pin must be fully engaged in the plate slot or the Lock Jaw Assembly will not seat properly, and the Handle Catch would not then engage the inner side wall of the plate. To be certain that the Lock Jaw Assembly has closed fully, attempt to pull the Release Handle without first lifting it. To discourage theft or pranksters, place a padlock through the obround hole above the Release Handle.

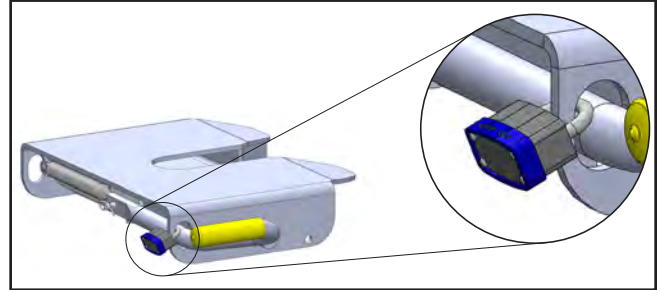

CAUTION: DO NOT ATTEMPT TO TRIP THE LOCK MECHANISM WITH YOUR HAND. USE A PROBE DEVICE TO SIMULATE THE KING PIN ACTION

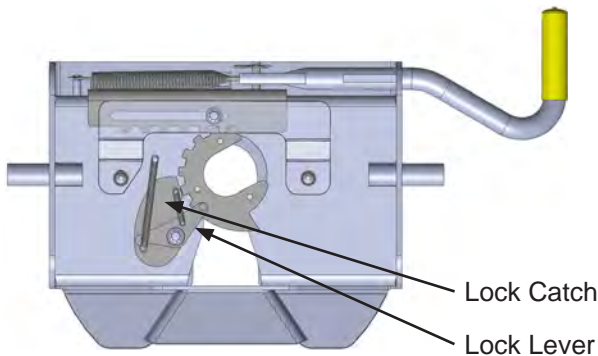

CLOSED -- LOCKED POSITION

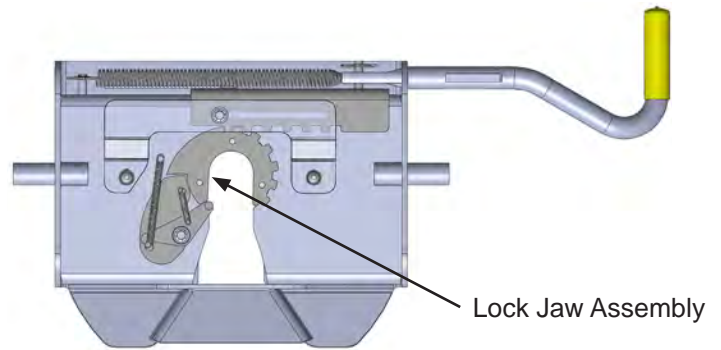

OPEN -- UNLOCKED POSITION

OPENING THE JAW ASSEMBLY

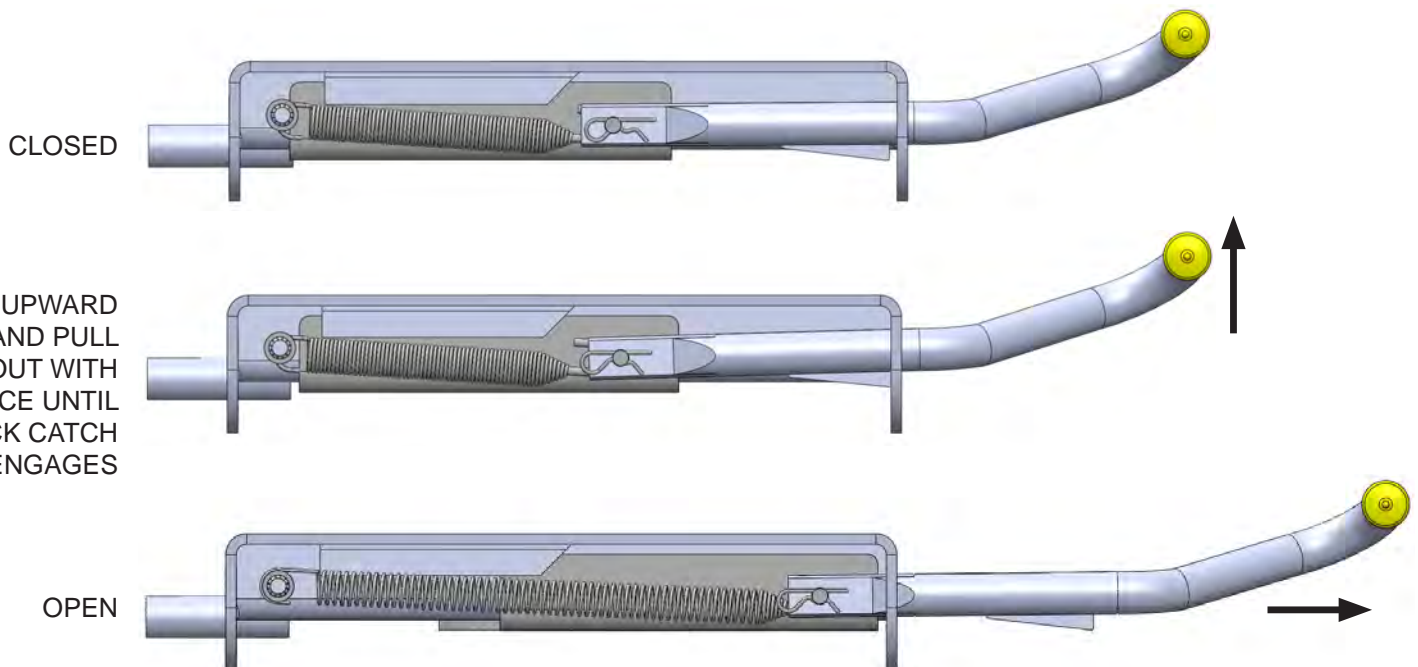

HITCHING

WARNING: Never perform any of the following actions while any part of a person is between the vehicle and trailer.

1. Align your truck with the center of the trailer. The truck should be close to parallel to the centerline of the trailer. Hitching can only be accomplished when the tow vehicle and the trailer are aligned within 16° of each other (see below).
2. Block the trailer wheels so the trailer will not roll back.
3. Lower your tailgate and back up until there is about 6" of clearance between the SuperGlide hitch and the end of the Capture Plate (sold separately and installed on your trailer's king pin plate). Raise or lower the front of the trailer so the bottom of the Capture Plate is aligned slightly above the beginning of the ramp area of the 5th Wheel Plate. This procedure will cause the front edge of the Capture Plate to "ride up" the ramp and flatten or tilt the hitch plate into a parallel position.

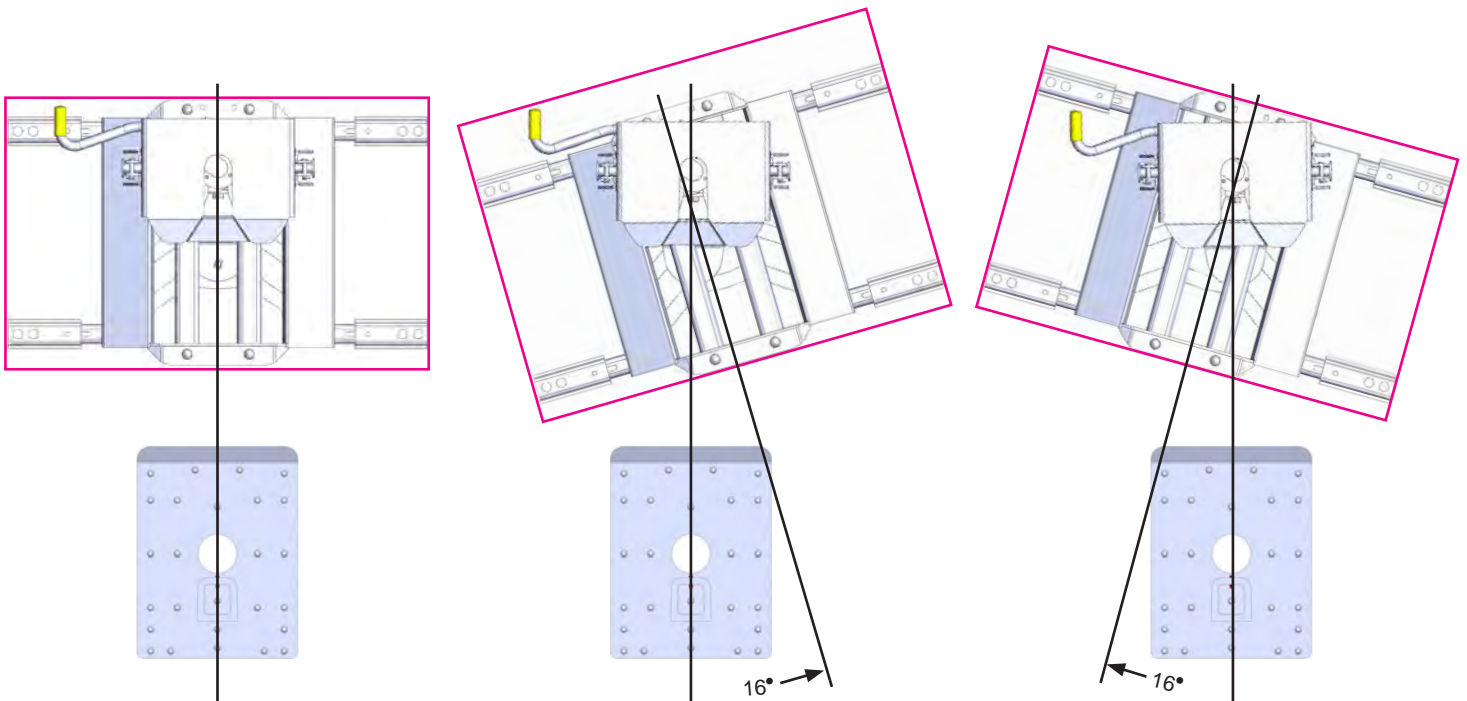

CAUTION: If this procedure is not followed, the king pin may bind in the plate mechanism and not lock-in properly. Following the procedure as outlined in Step 3 will ensure that you will not "high hook" the king pin in the plate. "High hooking" occurs when backing your hitch into a trailer that is set too high, resulting in the lower flange of the king pin to wedge itself against the metal edge of the lower horseshoe piece or against the Lock Jaw Assembly. Damage to the Lock Jaw Assembly may result and not allow smooth operation of the closing mechanism.

4. The Lock Jaw Assembly must be in the open position. Lift and pull out on the Release Handle to open the Lock Jaw Assembly.

CAUTION: Damage will result should you attempt to hook up with the Lock Jaw Assembly in the closed position.

5. Back up the truck in one fluid motion, so the king pin enters the center of the 5th Wheel Plate {A} opening.
6. Make sure the Lock Jaw Assembly is completely seated around the king pin (see illustration on pg. 8).
7. Be sure that the Release Handle has fully returned to the closed position and proceed to "Safety Checks" on pg. 10.

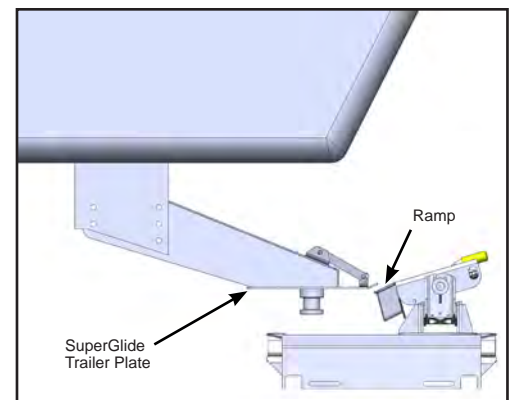

SAFETY CHECKS

1. Shine a light on the 5th Wheel Plate Lock Jaw Assembly making sure it has closed around the king pin.
2. Pull the Release Handle towards you without lifting it up. If the Lock Jaw Assembly is completely closed the Handle Catch will prevent you from being able to pull the Release Handle open.
3. Raise the trailer jack base plates just above the ground, lock your trailer brakes, then pull the tow vehicle slowly forward putting a strain on the trailer.
4. When you are assured that the trailer is safely hooked up, raise your trailer jacks into their full retracted position.

FAILURE TO PERFORM THESE SAFETY CHECKS MAY RESULT IN DAMAGES TO TRUCK AND TRAILER.

UNHITCHING

WARNING: Never perform any of the following actions while any part of a person is between the vehicle and the trailer.

1. Once you have the trailer located and are ready to unhitch, (unhitching can only be accomplished when the truck and trailer are aligned within 16 degrees of each other--see pg. 9), block the trailer wheels so it will not roll back or forward. Back into the blocked trailer slightly and set the parking brake while you are still in gear. This action will relieve pressure on the lock mechanism before attempting to release the latch mechanism.
2. Lower the trailer jacks to the point of just touching the ground but do not raise the trailer at this point.
3. Open the Lock Jaw Assembly by first lifting, then pulling the Release Handle towards you (see pg. 8).
4. Lower the trailer jacks until the bottom of the king pin box is almost free of the top of the 5th Wheel Plate {A}. Make certain that the bottom of the king pin is not so high that binding on the hitch Lock Catch would result.
5. After lowering the truck's tail gate, disconnect the trailer electrical cord and break-away switch cable, then pull forward.
6. As the king pin slides from the 5th Wheel Plate, notice that the locking mechanism remains open once the king pin is removed.

CAUTION: If it should be necessary to reposition your trailer, you must follow the hitching procedures to ensure the hitch is latched before moving the trailer. (pg. 9-10)

CAUTION: You may wish to keep the plate closed until you are ready to re-hitch to avoid injury or accidents to children or adults who attempt to operate the plate mechanism. **DO NOT ATTEMPT TO TRIP THE LOCK MECHANISM WITH YOUR HAND, USE A PROBE TO SIMULATE THE KING PIN.**

ADJUSTING THE TURNTABLE CAM ARM ASSEMBLY

This adjustment will need to be made periodically. If you are experiencing a bump or “clunk” when starting or stopping, or if the hitch is sliding up and down the way tubes when you are not hooked up to the trailer you can perform this adjustment to reduce the noise and keep the hitch in the forward towing position when not trailering.

1. The Roller, {C3} needs to be kept snug against the rear edge of the of the Cam Slot (see below).
2. To adjust, loosen the Shaft Stop Jam Nut {E5} located on the Shaft Stop Set Screw {E4}, under the 5th Wheel Plate {A} (on the side facing the front of your truck).
3. Tun the Set Screw by hand, adjusting incrementally, until resistance is felt when pulling the Turntable Cam Arm Assembly into the angled Cam Slot. While holding the Set Screw with one wrench, tighten the Jam Nut with another wrench.

WARNING: IF YOU OVER TIGHTEN THE ADJUSTING BOLT, YOU WILL COMPRESS THE NYLON BLOCK, AND MAY CAUSE DAMAGE TO THE HITCH.

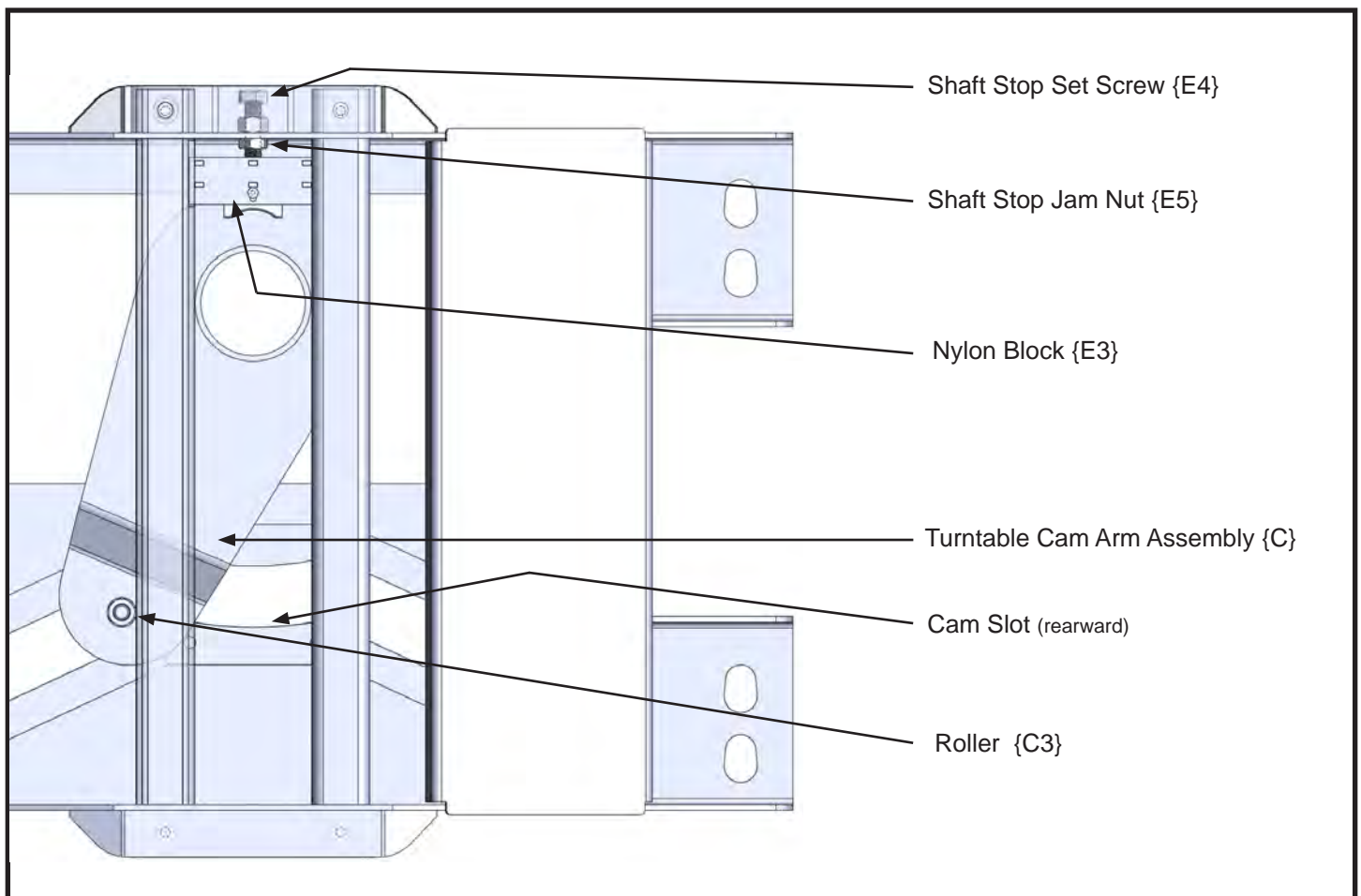

ALTERNATE PLACEMENT OF THE SHAFT STOP JAM NUT

Note: The placement of the jam nut may have already been placed in the alternate position during assembly.

1. Remove the 3/4" Shaft Stop Set Screw from the base
2. Remove the Jam Nut from the 3/4" bolt
3. Replace the 3/4" bolt into the base and thread the Jam Nut on to 3/4" bolt between the bulkhead and the stop block. This will allow easier access to the Jam Nut when tightening.

CHALLENGE VS. SOLUTION

CHALLENGE	SOLUTION
Cannot open the Release Handle.	You may have too much rearward pressure against the lock mechanism. Back your truck slightly to relieve pressure and continue the unhitching procedures.
Plate seems dry – Can I use a Teflon pad?	No. The Trailer Plate does not allow for any extra space for a pad. Since the turning action is no longer at the king pin, you will have minimal friction. A light coating of WD-40 or a light oil is sufficient.
Trailer overhang is hitting the truck bed rails when the trailer and truck are at sharp angles.	Most trailer king pin boxes have height adjustment settings available to achieve the necessary clearance between the truck bed rails and the bottom of the trailer. Adjust accordingly.
The latch handle mechanism seems too stiff to operate.	Turn the plate upside-down and spray the locking mechanism with WD-40. Work the handle until it slides freely. If the problem persists, you may need to degrease and re-lube all working parts.
I have attempted to unhitch at an angle greater than 16 degrees, truck to trailer and the hitch will not release the King Pin.	Back into the King Pin, then using a probe, push the Lock Lever forward until the Lock Catch allows the Lock Jaw Assembly to rotate around the king pin. Retract the trailer jacks and remove the wheel chocks. Maneuver the truck until it is lined up within the 16 degree limit (see step 1 on pg. 9). Perform unhitching steps 1-6 on page 10.
I need to have a professional evaluate my SuperGlide.	Contact PullRite's Customer Service Dept. at (800) 443-2307. Your needs will be assessed and resolved by PullRite or you will be directed to an authorized PullRite Service Center.

FREQUENTLY ASKED QUESTIONS

Can I pull other 5th wheel trailers with my SuperGlide hitch?

Your SuperGlide hitch can only pull trailers equipped with the SuperGlide trailer plate. If you hook up to a trailer that does not have a trailer plate installed, there is nothing keeping the hitch in the forward towing position and the weight of the trailer will cause the head to turn and slam or “free fall” to the rear which can cause damage to the hitch and the king pin. We do not recommend locking the hitch in any way to keep it in the forward position.

Will a standard hitch be able to tow my trailer with the trailer plate installed?

The trailer plate will need to be removed from the pin box before a standard fifth wheel hitch can tow your trailer. If the plate is not removed, the king pin will not rotate in the hitch and damage will result to the trailer plate. Part # 3336 is a conversion adapter (see pg. i) that will allow a standard fifth wheel hitch to tow your trailer with the trailer plate installed. The adapter is used in conjunction with the fifth wheel plate {A}, or “head” of the SuperGlide.

Are there plugs available to fill the holes drilled into my truck bed? (SuperRail)

We do not have plugs at the present time.

Is there a cover available for my SuperGlide hitch?

Not for the 24K SuperGlide.

Can I put a bed liner in my truck after the hitch is installed?

It is actually better to install a spray in bed liner after the hitch is installed. This will allow the holes that were drilled to be covered. A plastic bed liner, or bed mat can be put in after the hitch is installed but you will have to match up the holes in the bed to the bed liner and cut the holes accordingly. Longer mounting posts may be required and can be ordered through your dealer or direct.

How much does my SuperGlide weigh?

317 pounds. The posts, brackets, etc. can range from 50 lbs. to 85 lbs.

Can I leave the hitch attached to my trailer and use the trailer jacks to lift the hitch out of the truck?

Yes, you can use the trailer jacks to lift the hitch out of the truck. The hitch should not however be left hanging from the king pin. Once you have the hitch lifted out of the truck you should have a stand available to lower the hitch onto for storage.

FREQUENTLY ASKED QUESTIONS

Can I hook up or unhook at a 90 degree angle?

Hooking up can only be accomplished when the truck and trailer are aligned within 16 degrees of each other. See pages 6-7 for more information on hooking up. Unhooking by pulling the release handle can only be accomplished when the truck and trailer are aligned within 16 degrees of each other. In emergency situations you can pull the clevis pins and clips that attach the 5th wheel plate or "head" assembly to the rocker arm, lower your landing gear and raise the trailer up until the 5th wheel plate is free from the rocker arm. Pull forward from under the parked trailer. At that point you can pull the release handle, remove the head from the king pin and reattach it to your hitch with the clevis pins and clips.

Can I use a Teflon disc or lube plate on the king pin plate?

The king pin box and SuperGlide plate or "head" move together and since there is no friction, there is no need for any grease or a lube plate. Use of a Teflon disc or lube plate would cause the king pin to be short and problems hooking up will occur.

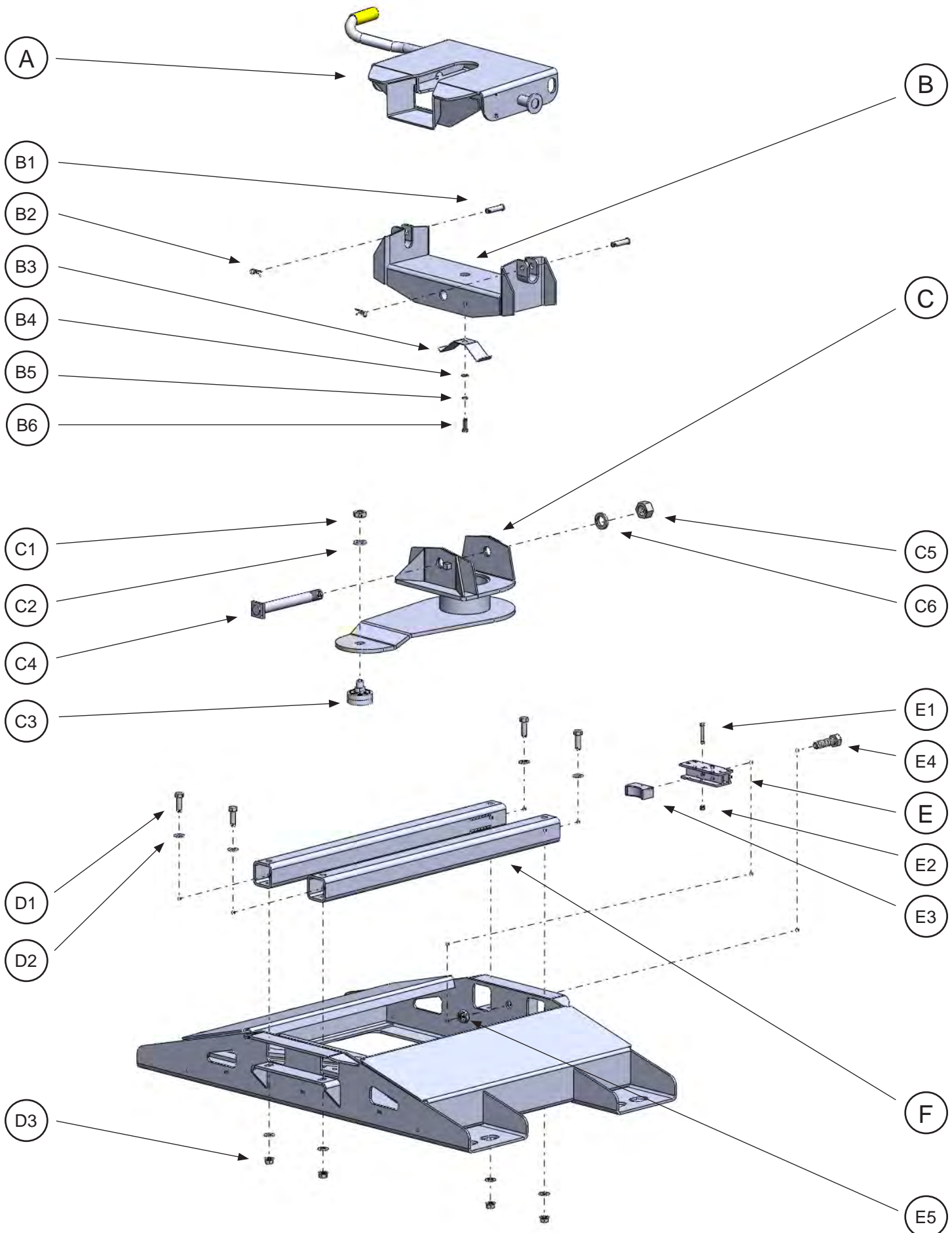

PARTS LIST

ITEM	DESCRIPTION	PART NO.	QTY.	MATERIAL
A	5TH WHEEL PLATE ASSEMBLY	3601	1	
B	ROCKER ARM	3502	1	(See assembly components below in hardware kit)
C	TURNTABLE CAM ARM	3603	1	
C1	JAM NUT	98150142	1	3/4"-16 HEX JAM NUT
C2	LOCK WASHER	98200124	1	3/4" LOCK WASHER
C3	ROLLER	410304	1	(Roller Assembly)
E	FORWARD SHAFT STOP BRACKET	3606	1	
E1	SHAFT STOP BOLT	98410233	1	1/4"-20 X 1-3/4" HHCS, GRD 5
E2	SHAFT STOP NUT	98410255	1	1/4"-20 NYLOCK NUT
E3	NYLON STOP BLOCK	36060104	1	
E4	SHAFT STOP SET SCREW	98010128	1	3/4"-10 X 2-1/2" HHCS GRD 5
E5	SHAFT STOP JAM NUT	98150143	1	3/4"-10 HEX JAM NUT
F	TURNTABLE WAY TUBES	3604	2	
HARDWARE KIT -- 4110				
B1	ROCKER ARM CLEVIS PIN	98410111	2	1-2" X 2" CLEVIS PIN
B2	PIN CLIP	98410127	2	#3 COTTER PIN
B3	ROCKER ARM SPRING	35100001	1	16 GA SPRING STEEL
B4	ROCKER ARM SPRING FLAT WASHER	98250160	1	5/16" ZINC FLAT WASHER
B5	ROCKER ARM SPRING LOCK WASHER	98200159	1	5/16" ZINC SPLIT LOCK WASHER
B6	ROCKER ARM SPRING BOLT	98010244	1	5/16"-18 X 1" HHCS GRD 5
C4	ROCKER ARM PIVOT BOLT	140501	1	1"-8 X 9-1/2" HHCS
C5	PIVOT BOLT HEX NUT	98150120	1	1" - 8 SAE ZINC HEX NUT
C6	PIVOT BOLT LOCK WASHER	98200115	1	1" ZINC PLATED SPLIT LOCK WASHER
D1	WAY TUBE BOLT	98010167	4	1/2"-13 X 1-1/2" HHCS GRD. 5
D2	WAY TUBE FLAT WASHER	98250145	8	1/2" FLAT WASHER
D3	WAY TUBE FLANGE NUT	98150201	4	1/2" - 13 ZINC, SERRATED FLANGE NUT
D4	HITCH PIN	08060001	4	1/2" ROUND
BASE RAIL KIT				
<i>BASE RAILS ARE DIFFERENT FOR EACH APPLICATION AND ARE SOLD SEPARATELY. CALL (800) 443-2307 FOR MORE INFORMATION.</i>				



SLIPPLATE™ INSTRUCTIONS

REMOVAL OF HITCH COMPONENTS

1. Remove the 5th Wheel Plate Assembly {A} of the hitch by pulling the clip {B2} and pin {B1} from either side of the plate (see Figure 1). Set parts aside for reassembly in later steps.
2. At this time, remove any excess lubrication that is presently on the Way Tubes {F}, this will reduce the mess when removing the Way Tubes from the base.
3. Remove the four 1/2" bolts {D1} that fasten the Way Tubes to the base of the hitch. Retain the bolts, flatwashers {D2}, and flange nuts {D3} (see Figure 2).
4. Pull both Way Tubes from the forward bulkhead by pulling them both toward the rear (tailgate end) of the hitch enough to where they are free from the front end (see Figure 2).
5. Remove the Nylon Stop Block {E} from between the way tubes and set aside (see Figure 3).
6. Remove the way tubes completely from the base.
7. Remove the Rocker Arm {B1} and Cam Arm Assembly {C1} from the base of the hitch.

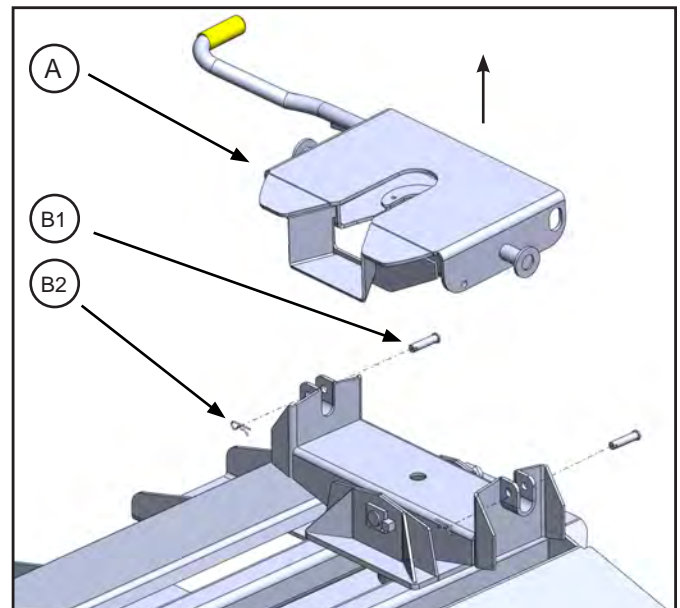

Figure 1

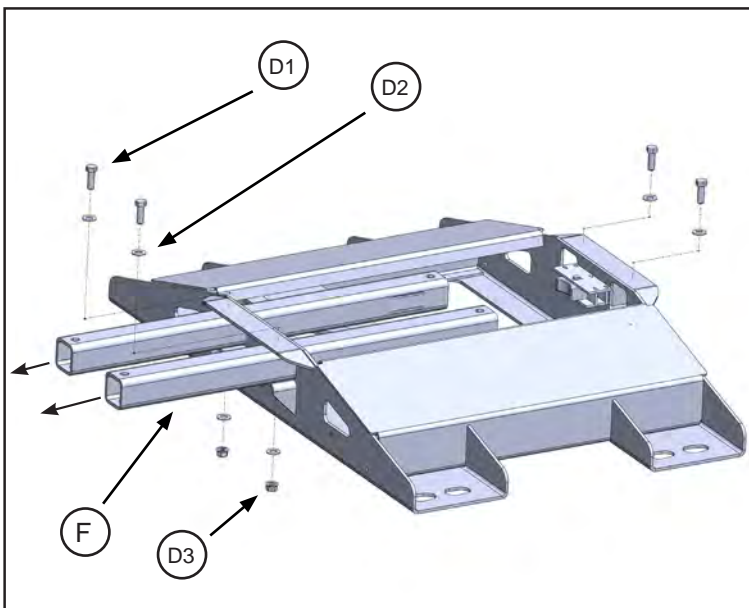

Figure 2

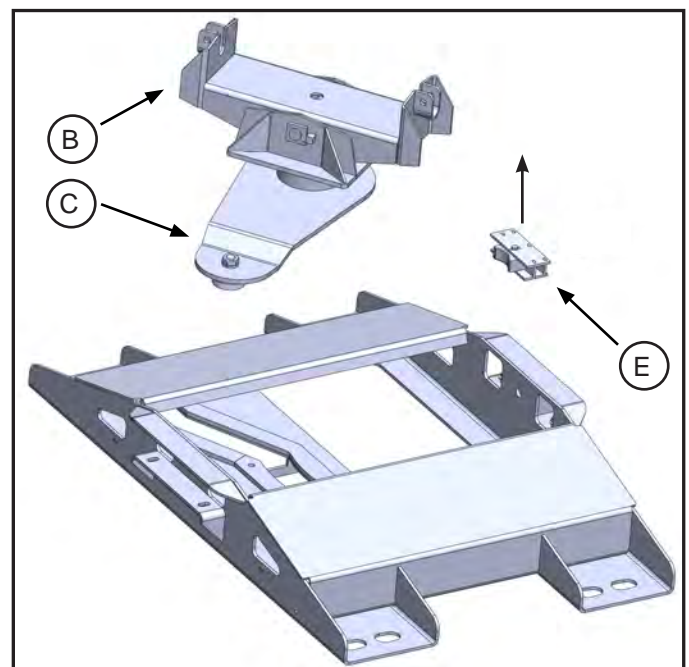

Figure 3

PREPARING THE WAY TUBES AND CAM ARM FOR APPLICATION

1. Clean any old lubrication from both Turntable Way Tubes {F} and the Turntable Cam Arm {C}, using a degreasing product (e.g., WD-40, automotive brake cleaner, or paint thinner)
2. Lightly file any imperfections that you can feel above the surface of the metal.
3. Lightly sand all four sides of the Way Tubes -- this will help “rough up” the surface, allowing the SlipPlate™ to adhere to the metal surface more effectively.
4. You will want to follow the same steps for the portions of the Cam Arm that make contact with the *top and inside surfaces* of the Way Tubes.

Way Tube Application -- Spray an even coating of the SlipPlate™ on the full length of each of the four sides of the Way Tubes. Allow approximately 15 minutes dry time per side. Repeat for *two* full coats.

Cam Arm Application -- Spray an even coating of SlipPlate™ on the surfaces of the Cam Arm that make contact with the Way Tubes. You will want to put two coats on these surfaces for your first application.

REASSEMBLING THE HITCH

1. Set the Cam Arm on the base of the hitch so the Roller {C3} bearing rests in the center portion of the cam slot.
2. Slide the Way Tubes through the rearward holes in the base in the same manner they were removed. Position them so the Way Tubes sit between the upper and lower portion of the Cam Arm.
3. Reinstall the Nylon Stop Block between the Way Tubes.
4. Slide the Way Tubes into the forward bulkhead.
5. Fasten the Way Tubes to the base of the hitch using the four 1/2" bolts and flange nuts.

MAINTENANCE USING SlipPlate™

It is necessary to inspect the Way Tubes before you begin each trip. Apply a liberal coating of SlipPlate™. On a daily basis, while towing, you will need to inspect the full length of the Way Tubes to see if you need to reapply the SlipPlate™.



#3336 Conversion Adapter

When your trailer's king pin box has been equipped with any welded Capture Plate or bolted-on Universal Capture Plate, this adapter will allow your trailer to be pulled by a non-SuperGlide hitch **when used in conjunction with the head of your SuperGlide (sold separately #3336)**.

NOTE: Most SuperGlide customers elect to use a custom, removable capture plate, rendering this adapter unnecessary.

1. Remove the SuperGlide Fifth Wheel plate (part# 3601) from the SuperGlide hitch by removing both 1/2" x 2" clevis pins (part #98410111) and pin clips (part #98410127).
2. Slide the SuperGlide Conversion Adapter onto the 5th wheel plate of the "brand X" hitch as seen in Step 1, making certain the Conversion Adapter is securely locked into place.
3. Insert the SuperGlide Fifth Wheel Plate (your SuperGlide hitch head) into the Conversion Adapter "cradles," and secure with the 1/2" x 2" clevis pins and clips.
4. The Conversion Adapter allows the king pin to turn in the conventional style hitch when hooked up to the trailer equipped with a SuperGlide Capture Plate.

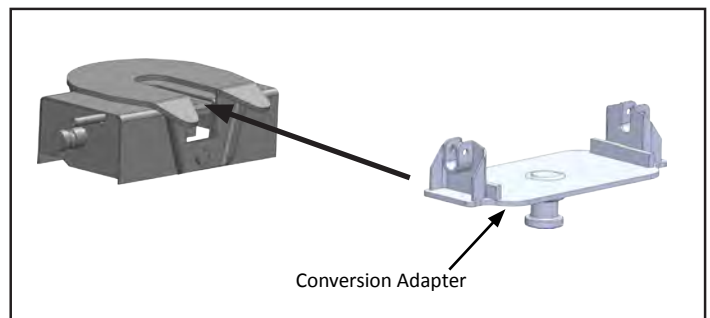

Step 1

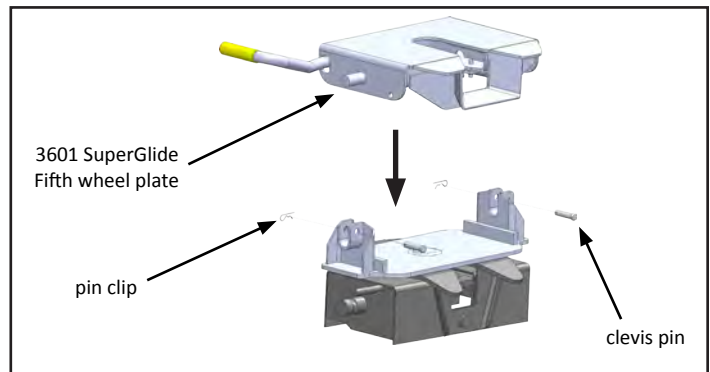

Step 2

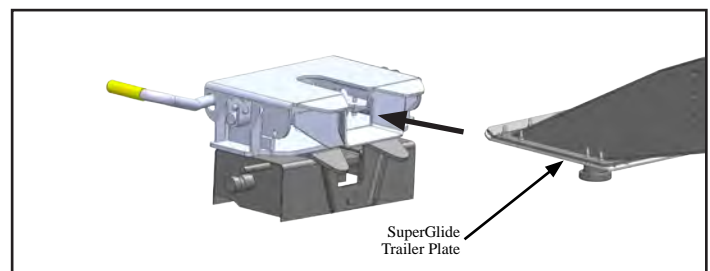

Step 3

NOTE: Hook-up *must* be performed in a straight line.



MANUFACTURED BY:
PULLIAM ENTERPRISES, INC.
13790 East Jefferson Blvd.
Mishawaka, IN 46545
(574) 259-1520 • (800) 443-2307
info@pullrite.com • www.pullrite.com

5 YEAR LIMITED WARRANTY

PULLIAM ENTERPRISES, INC. hereinafter referred to as "PULLIAM", warrants to the first retail owner only, this PullRite towing system to be free from defects in materials and workmanship for a period of five (5) years or 31,068 miles (50,000 km) after the installation on purchaser's vehicle, whichever occurs first.

To validate this warranty, the first retail owner must mail the provided warranty card to PULLIAM, or register online at www.pullrite.com, within ten (10) days after installation of said towing system on his vehicle.

The owner is responsible for all normal and preventative maintenance described in the Owner's Manual.

If any defect occurs which the owner believes is covered by this warranty within said five (5) year period, the owner shall contact PULLIAM immediately, either in writing or by telephone call, Attention Customer Service Department. The owner will be instructed to return the hitch at his expense either to an authorized PullRite dealer or to PULLIAM to repair or replace any parts necessary to correct defects in material or workmanship.

Repair or replacement shall be at the sole option of PULLIAM and shall be completed by or on behalf of PULLIAM free of charge for materials and labor.

This warranty gives you specific legal rights, and you may also have other right's which vary from state to state.

THIS WARRANTY SPECIFICALLY *EXCLUDES* EACH OF THE FOLLOWING:

1. Defects in the product resulting from misuse, neglect, accident, loading beyond the vehicle's capacity, failure to comply with instructions contained in the Owner's Manual or unauthorized repairs, replacements, alterations or modifications. "Unauthorized repair, replacements, alterations" are those made without PULLIAM'S prior knowledge and consent.
2. Any incidental or consequential damage including, but not limited to, loss of use of the vehicle, towing charges, vehicle rental, loss of time, inconvenience, travel, gasoline, lodging and telephone expenses, loss of revenue and damages on account of personal injury and property damage. (Some states do not allow the exclusion or limitation of incidental or consequential damages, so these limitations may not apply to you).
3. Repairs or replacements of defects in any PullRite towing system, or part thereof, installed on any vehicle which has been rented, leased or used for any commercial purpose.
4. Any representation, warranty of undertaking made by any dealer or third party beyond the scope of the warranty herein expressed.
5. Any problem resulting in normal deterioration due to wear or exposure.

TO THE EXTENT PERMITTED BY LAW, IMPLIED WARRANTIES OF MERCHANTABILITY AND FITNESS FOR A PARTICULAR PURPOSE ARE LIMITED IN DURATION TO FIVE YEARS FROM THE DATE OF INSTALLATION ON THE FIRST OWNER'S VEHICLE. (SOME STATES, HOWEVER, DO NOT ALLOW LIMITATIONS AS TO DURATION OF IMPLIED WARRANTY, SO THOSE LIMITATIONS MAY NOT APPLY TO YOU)



Product Warranty Registration

As an owner of a PullRite product, you must register your product to be considered for warranty coverage. See Owners Manual for further details.

Please note, that you can also register online at www.pullrite.com/warranty.htm.

Name: _____

Address: _____

City: _____ State: _____ Zip: _____

Email Address: _____

Phone (optional): _____

Purchase Price: _____ Date of Purchase: _____

Dealer's Name: _____

Dealer's Address: _____

Dealer's City: _____ Dealer's State: _____ Dealer's Zip: _____

Dealer's Phone: _____

Model Purchased: _____

Vehicle Make: _____ Vehicle Model: _____ Vehicle Year: _____

Vehicle Year: _____ Vehicle Cab Style: _____ Vehicle Bed Length: _____

Did you receive an Owners Manual from the Dealer? Yes / No

What influenced you to buy your hitch? _____

Comments:



MANUFACTURED BY:

PULLIAM ENTERPRISES, INC.
13790 East Jefferson Blvd.
Mishawaka, IN 46545
(574) 259-1520 • (800) 443-2307
info@pullrite.com • www.pullrite.com