



# BLUE OX®

## Installation Instructions

**BX 88230**  
**Class III Bumper Mount**  
**Type**

### Installation for Class III Bumper Mount Type BX88230

The installation of this baseplate requires drilling four 17/32” holes in the bumper.

#### PARTS LIST

Ref #	Qty.	Part #	Description
1	2	61-4260	WLDM'T ADAPTOR PLATE, DM1030,9595
2	4	201-0283	1/2-13 X 2 HEX BOLT, GRD 5, ZP.
3	4	202-0005	1/2-13 HEX NUT, ZP
4	4	203-0012	1/2 LOCK WASHER, ZP
5	4	201-0337	1/2-13 X 6 1/2 HEX HEAD BOLT,GRD. 5
6	2	102-5461	BACKING BRACE, BX1108
7	4	203-0005	1/2 FLAT WASHER, ZP
8	1	63-3445	BOLT BAG, BX88230

3. The tabs are not welded in the center of the baseplate, be certain that the tabs are offset to the center of the bumper (as shown in the diagram). Attach the baseplate to the bumper using the inside bracket holes and the bumper holes drilled in Step 2.

4. Mark 17/32” holes in the bumper for the outer bracket holes, using the bracket as a template.

5. Remove the brackets and drill 17/32” holes in the bumper at the points marked.

6. Install the brackets using all the holes and hardware. **NOTE: IF THE BUMPER SHOULD HAVE A TUBE BEHIND IT, DRILL THROUGH BOTH AND USE THE LONGER BOLTS AND BACKING BRACES PROVIDED. IF USING AN A FRAME TOW BAR, CHECK THAT IT MOVES FREELY UP AND DOWN BEFORE FINAL TIGHTENING BE SURE AND USE LOCTITE ON ALL BOLTS BEFORE TIGHTENING. TORQUE ALL BOLTS ACCORDING TO TORQUE CHART IN GENERAL INSTRUCTION SHEET.**

7. Install the tow bar and safety cables according to the instructions included in their packages.

8. Do not substitute other devices if the pin and clip are lost.

9. **DEALER OR INSTALLER: BE CERTAIN THE USER RECEIVES THE INSTRUCTION SHEET.**

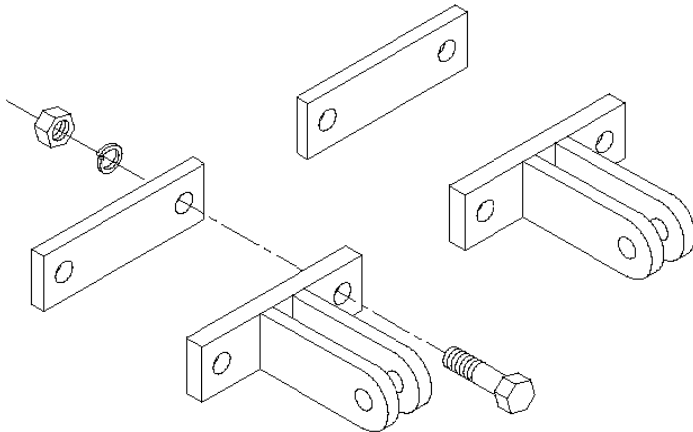

### Installation Instructions

1. Most vehicle bumpers are NOT suitable for towing without modification and reinforcement. These brackets should never be attached over rubber or plastic. The mounting brackets should be attached metal to metal and to a flat surface. The bumper and the bumper bracket may need to be reinforced. If you are not sure, consult a skilled hitch mechanic.

2. Locate the center of your bumper and measure out 10 9/16” to either side. From the center of that mark measure over 21 1/8” to the opposite side. Drill 17/32” holes at these marked points.



# BLUE OX®

© 2006 Blue Ox  
One Mill Road, Industrial Park  
Pender, Nebraska 68047  
Phone: (402) 385-3051  
Fax: (402) 385-3360  
www.blueox.us