

MAGNUM
ENERGY

MS Series
Pure Sine Wave
Inverter/Charger



Owner's Manual

MAGNASINETM
MAGNUM

Disclaimer of Liability

Since the use of this manual and the conditions or methods of installation, operation, use and maintenance of the MS Series Inverter/Charger is beyond the control of Magnum Energy Inc., this company does not assume responsibility and expressly disclaims liability for loss, damage or expense, whether direct, indirect, consequential or incidental, arising out of or anyway connected with such installation, operation, use, or maintenance.

Due to continuous improvements and product updates, the images shown in this manual may not exactly match the unit purchased.

Restrictions on Use

The MS Series Inverter/Charger shall not be used in connection with life support systems, life saving or other medical equipment or devices. Using the MS Series Inverter/Charger with this particular equipment is at your own risk.

Copyright Notice

Copyright © 2004, 2009 by Magnum Energy, Inc. All rights reserved. Permission to copy, distribute and/or modify this document is prohibited without express written permission by Magnum Energy, Inc.

Contact Information

Magnum Energy, Inc.
2211 West Casino Rd.
Everett, WA 98204
Phone: 425-353-8833
Fax: 425-353-8390
Web: www.magnumenergy.com

Record the unit's model and serial number in case you need to provide this information in the future. It is much easier to record this information now, instead of trying to gather it after the unit has been installed.

Model Number _____

Serial Number _____

Magnum Energy® is a registered trademark of Magnum Energy, Inc.

IMPORTANT SAFETY INSTRUCTIONS

- This manual contains important safety instructions that must be followed during the installation and operation of this product.
- All electrical work must be performed in accordance with local, state and federal electrical codes.
- Read all instructions and safety information contained in this manual before installing or using this product.
- This product is designed for indoor/compartment installation. It must not be exposed to rain, snow, moisture or liquids of any type.
- Use insulated tools to reduce the chance of electrical shock or accidental short circuits.
- Remove all jewelry such as rings, watches, bracelets, etc., when installing or performing maintenance on the inverter.
- Always disconnect the batteries or energy source prior to installing or performing maintenance on the inverter.
- Live power may be present at more than one point since an inverter utilizes both batteries and AC.
- Always verify proper wiring prior to starting the inverter.
- There are no user serviceable parts contained in this product.
- This unit is provided with integral protection against overloads.
- The input and output AC and DC circuits are isolated from the inverter chassis. The inverter system grounding is the responsibility of the installer in accordance with the NEC/CEC, ABYC, RVIA, and local codes.
- Both AC and DC overcurrent protection must be provided as part of the installation.
- Use Class 1 wiring methods for field wiring connections to terminals of a Class 2 circuit.
- Use only copper wires with a minimum temperature rating of 90°C.
- Listed or labeled equipment shall be installed and used in accordance with any instructions included in the listing or labeling.

Safety Symbols

To reduce the risk of electrical shock, fire, or other safety hazard, the following safety symbols have been placed throughout this manual to indicate dangerous and important safety instructions.



WARNING: This symbol indicates that failure to take a specified action could result in physical harm to the user.



CAUTION: This symbol indicates that failure to take a specified action could result in damage to the equipment.



Info: This symbol indicates information that emphasizes or supplements important points of the main text.



Remedy: This symbol provides possible solutions for related issues.

SAVE THESE INSTRUCTIONS

IMPORTANT BATTERY SAFETY INSTRUCTIONS

- Be very careful when working around batteries, they can produce extremely high currents if short-circuited. Read the battery supplier's precautions before installing the inverter and batteries.
- Wear eye protection such as safety glasses when working with batteries.
- Remove all jewelry such as rings, watches, bracelets, etc., when installing or performing maintenance on the inverter.
- Never work alone. Always have someone near you when working around batteries.
- Use proper lifting techniques when working with batteries.
- Never use old or untested batteries. Check each battery's label for age, type and date code to ensure all batteries are identical.
- Batteries are sensitive to changes in temperature. Always install batteries in a stable environment.
- Install batteries in a well ventilated area. Batteries can produce explosive gasses. For compartment or enclosure installations, always vent batteries to the outside.
- Provide at least one inch of air space between batteries to provide optimum cooling.
- Never smoke when in the vicinity of batteries.
- To prevent a spark at the battery and reduce the chance of explosion, always connect the cables to the batteries first. Then connect the cables to the inverter.
- Use insulated tools at all times.
- Always verify proper polarity and voltage before connecting the batteries to the inverter.
- To reduce the chance of fire or explosion, do not short-circuit the batteries.
- In the event of accidental exposure to battery acid, wash thoroughly with soap and water. In the event of exposure to the eyes, flood them for at least 15 minutes with running water and seek immediate medical attention.
- Recycle old batteries.

SAVE THESE INSTRUCTIONS

Table of Contents

1.0	Introduction	1
1.1	Features and Benefits	2
1.2	How an Inverter/Charger Works	5
1.3	Advantages of a Pure Sine Wave vs Modified Sine Wave Inverter	5
1.4	Appliances and Run Time	6
2.0	Installation	7
2.1	Pre-Installation	7
2.2	Mounting the Inverter	10
2.3	Wiring the Inverter - General Requirements	12
2.4	DC Wiring	13
2.5	AC Wiring	20
2.6	Grounding Inverters	30
2.7	Inverter Notification Requirements	37
2.8	Final Inspection	37
2.9	Functional Test	38
3.0	Operation	39
3.1	Inverter Mode	39
3.2	Standby Mode	40
3.3	Battery Charging	40
3.4	Transfer Time	42
3.5	Battery Temperature Sensor Operation	42
3.6	Protection Circuitry Operation	43
3.7	Inverter Startup	44
3.8	Factory Default Values	45
4.0	Maintenance and Troubleshooting	46
4.1	Recommended Inverter and Battery Care	46
4.2	Storage for Mobile Installations	46
4.3	Troubleshooting	47
4.4	Resetting the Inverter	48
Appendix A - Specifications and Optional Equipment		49
A-1	Inverter/Charger Specifications	49
A-2	Inverter Efficiency	50
A-3	AC Input Voltage to Output Charge Amps	50
A-4	Optional Equipment and Accessories	51
Appendix B - Battery Information		52
B-1	Battery Location	52
B-2	Battery Types	52
B-3	Battery Temperature	52
B-4	Battery Bank Sizing	52
B-5	Battery Bank Sizing Worksheet	53
B-6	Battery Wiring Configurations	54
Limited Warranty		57
How to Receive Repair Service		57

List of Figures

Figure 1-1, Power Switch, Status LED and Accessory Connection Ports.....	3
Figure 1-2, Electrical Connection Points	3
Figure 1-3, Left Side Features	4
Figure 2-1, Simplified Installation Diagram for Permanent Installations	8
Figure 2-2, Approved Mounting Positions	10
Figure 2-3, MS Series Dimensions.....	11
Figure 2-4, DC and Battery Temperature Sensor Wiring	14
Figure 2-5, Battery Hardware Installation	16
Figure 2-6, Inverter DC Hardware Installation	16
Figure 2-7, Battery Temperature Sensor	18
Figure 2-8, MS Series Inverter/Charger - AC Wiring	21
Figure 2-9, MS Series Inverter/Charger - AC Wiring (Access Panel)	21
Figure 2-10, AC Terminal Block.....	22
Figure 2-11, AC Wiring for Single In - Single Out (30 A) Configurations	25
Figure 2-12, AC Wiring for Single In - Single Out (60 A) Configurations	26
Figure 2-13, AC Wiring for Single In - Dual Out Configurations	27
Figure 2-14, AC Wiring for Dual In - Single Out Configurations	28
Figure 2-15, AC Wiring for Dual In - Dual Out Configurations.....	29
Figure 2-16, Grounding System for MS Series	30
Figure 2-17, Multiple Connections to DC Ground Rod (Method 1).....	31
Figure 2-18, Multiple Connections to DC Ground Rod (Method 2).....	32
Figure 2-19, Single Connection to DC Ground Rod (Method 3)	32
Figure 2-20, Neutral-to-Ground Connection (Inverter Mode).....	35
Figure 2-21, Neutral-to-Ground Connection (Standby Mode).....	35
Figure 2-22, Disconnecting the Ground-to-Neutral connection.....	36
Figure 2-23, Large ground wire connected to MS Series.....	36
Figure 2-24, Warning Label	37
Figure 2-25, AC Voltage Checks.....	38
Figure 3-1, Power Flow - Inverter Mode	39
Figure 3-2, Power Flow - Standby Mode.....	40
Figure 3-3, Automatic 4-Stage Charging Graph.....	41
Figure 3-4, BTS Temperature to Charge Voltage Change	42
Figure 3-5, Power Switch and Status Indicator.....	44
Figure 4-1, Performing an Inverter Reset	48
Figure 4-2, MS Series Efficiency Chart	50
Figure 4-3, MS Series Output Charger Current Chart	50
Figure B-1, Series Battery Wiring.....	54
Figure B-2, Parallel Battery Wiring	54
Figure B-3, Series-Parallel Battery Wiring.....	54
Figure B-4, Battery Bank Wiring Examples (12-volt).....	55
Figure B-5, Battery Bank Wiring Examples (24-volt).....	56

List of Tables

Table 1-1, Typical Appliance Power Consumption.....	6
Table 2-1, Recommended DC Wire/Overcurrent Device for Rated Use	15
Table 2-2, DC Wire Size For Increased Distance	16
Table 2-3, AC Input/Output Wiring Configurations	24
Table 2-4, AC Grounding Electrode Conductor Sizing	31
Table 2-5, Equipment Grounding Conductor Sizing	33
Table 3-1, Inverter Battery Turn On/Off Levels.....	43
Table 3-2, Inverter/Charger Default Values	45
Table 4-1, Basic Troubleshooting.....	47

1.0 Introduction

Congratulations on your purchase of the MS Series inverter/charger from Magnum Energy. The MS Series is a "pure" sine wave inverter designed especially for rugged mobile applications, home backup power and stand-alone applications. Powerful, yet simple to use, this inverter/charger will provide you with years of trouble-free performance you have come to expect from Magnum Energy.

Installation is easy. Simply connect the inverter's output to your distribution circuits or electrical panel; connect your utility or AC generator power to the inverter's easy-to-reach terminal block; connect the batteries, and then switch it on for power.

With the optional accessories listed below you can control and monitor many other Magnum Devices.

The MS Series Inverter/Charger includes the following:

- 2000, 2800, or 4000 Watt Models in a small footprint - less weight and area needed for installation
- Pure Sine Wave Output
- Automatic PFC (Power Factor Corrected) multi-stage battery charging
- RS485 standard communication protocol
- Remote and Network ports (easy connection for optional accessories)
- ON/OFF Inverter-mounted switch with LED indicator
- 60 Amp AC Transfer available (using Dual IN/Dual OUT wiring)
- Large AC access and terminal block [wire size: 14 to 6 AWG (2.1 to 13.3 mm²) CU]
- DC terminal covers with 360 degree connection
- Field Serviceable for qualified personnel - tested repair kits available
- Smooth, aesthetically pleasing design
- ETL listed to UL/cUL STDs 458, 1741 and CSA STD 22.2 107.01-01 for safety.
- Automatic battery temperature compensation (using battery temperature sensor) - for optimum charging even during extreme temperature changes
- Over-current, over-temperature, and high/low battery voltage protection

The following accessories are also available for use with the MS Series inverter/charger:

- ME-RC (Remote Control Display) - communicates with the inverter to: 1. Easily operate and monitor your inverter and charger from a remote location; 2. Configure the inverter's adjustable settings and maintain these settings with nonvolatile memory; 3. Provide text display to help with troubleshooting inverter faults.
- ME-AGS-N (Automatic Generator Start Module - Network version) - communicates with the inverter to automatically start/stop your connected generator.
- ME-BMK (Battery Monitor Kit) - communicates with the inverter to provides precise DC voltage/current measurements and information on the battery's State of Charge (SOC).
- ME-CB (Conduit Box) - provides 1/2" - 2" knockouts for connecting AC and DC conduit runs to the inverter.
- ME-SBC (Smart Battery Combiner) - monitors and keeps a second battery charged using a portion of the current that is charging a main battery.

Introduction

1.1 Features and Benefits

The MS Series inverter/charger is designed to allow easy access to wiring, circuit breakers, controls and for viewing the LED (Light Emitting Diode) status indicator. Its die cast base plate with one piece aluminum cover ensures maximum durability with minimum weight, as well as cooler more efficient operation.

The front of the MS Series is equipped with the following features (see figures 1-1 and 1-2):

- **(1) Power Switch** - a momentary push-button switch that alternately turns the inverter ON or OFF.
- **(2) Status LED Indicator** - this green LED illuminates to provide information on the inverter or charger operation.
- **(3) Stack Connection Port (red label)** - a RJ11 port that allows series-stacking and accepts the optional RSAs (Remote Switch Adapters) which allows remote on/off switch operation.



Info: The series-stacking capability, which allows two units to provide 120/240 VAC output is only available on the MS4024 Series Inverter/Charger.

- **(4) Magnum Net Connection Port (green label)** - a RJ11 port that accepts optional Network capable accessories (i.e., Auto Gen Start or Battery Monitor).
- **(5) Remote Connection Port (blue label)** - a RJ11 port that allows the optional remote control display to be connected.
- **(6) BTS Connection Port (yellow label)** - a RJ11 port that accepts the remote Battery Temperature Sensor (BTS) accessory.
- **(7) Mounting Flange** - used to secure the inverter to a shelf or wall.
- **(8) AC Entry/Exit Connections** - two 3/4" knockouts provided with cable-clamp strain reliefs to allow and hold the AC input and output field wiring.
- **(9) Intake Air Vents** - ventilation openings to pull in air to help keep the inverter cool for peak performance.
- **(10) Positive DC Terminal** - provides 360 degree connection point for the positive (+) cable from the battery bank; provided with a 5/16-18 stainless Kep nut¹ on a 5/16-18 bolt to hold the battery cable to the DC terminal which uses.
- **(11) Negative DC Terminal** - provides 360 degree connection point for the negative (-) cable from the battery bank; provided with a 5/16-18 stainless Kep nut¹ on a 5/16-18 bolt to hold the battery cable to the DC terminal.
- **(12) DC Equipment Ground Terminal** - this connection is used to tie the exposed chassis of the inverter to the DC grounding system. This terminal accepts one CU/AL conductor from #14 to # 2 AWG (21. to 33.6 mm²)

¹Note 1 - Hex nut with external tooth lock washer

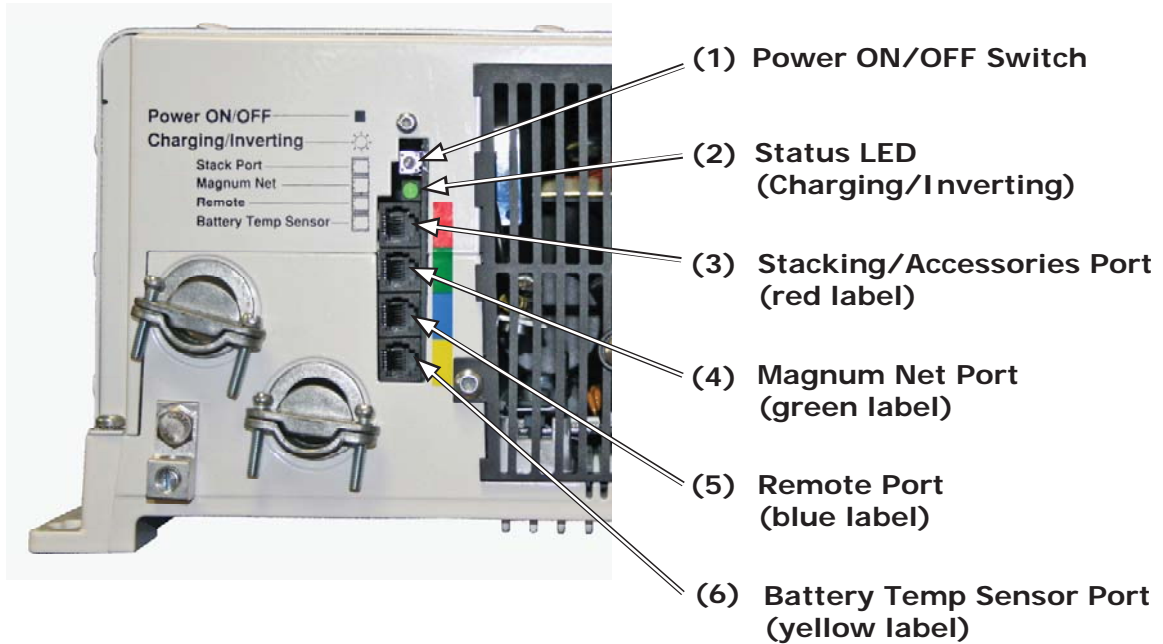

Figure 1-1, Power Switch, Status LED and Accessory Connection Ports

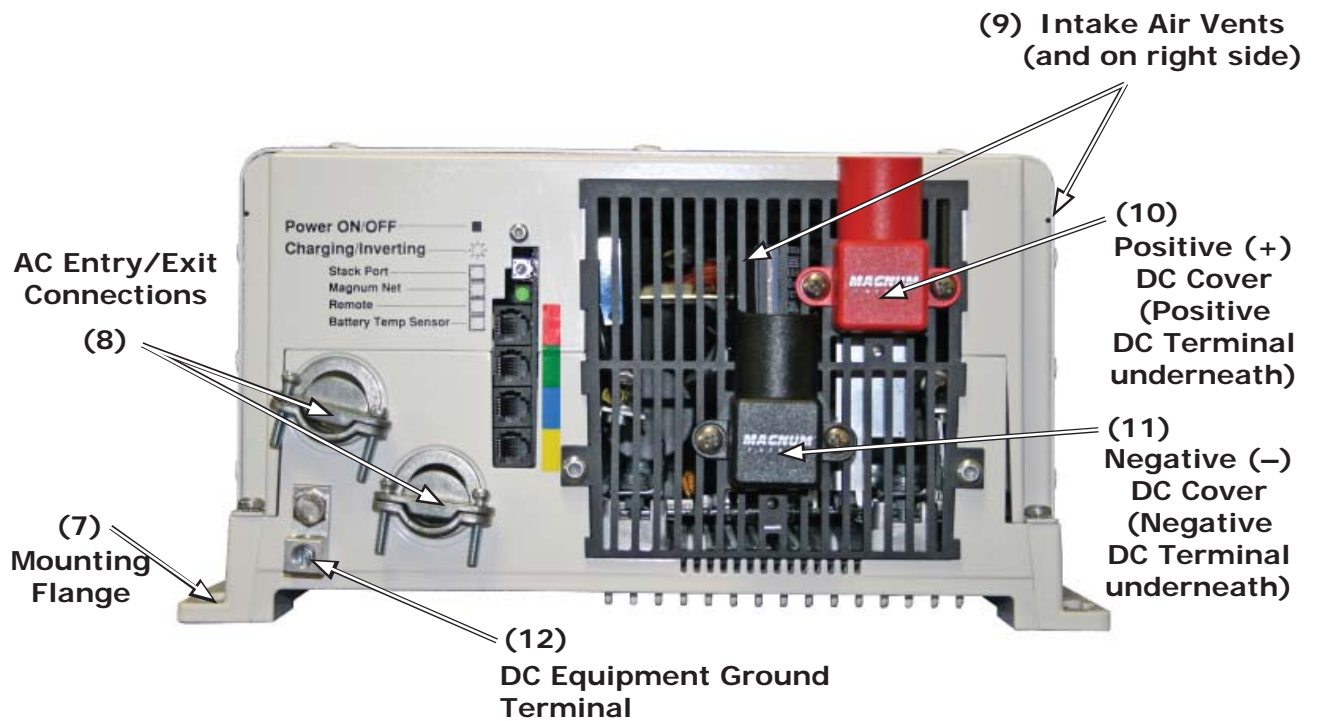

Figure 1-2, Electrical Connection Points

Introduction

The left side of the MS Series is equipped with the following features (see to figure 1-3):

- **(13) Exhaust Air Vent** - ventilation openings that allow heated air to be removed by the internal cooling fan.
- **(14) Model/Serial Number Label** - includes model/serial number information, date of manufacture and inverter and charger specifications. See Appendix A for more information and to find the available models.
- **(15) AC Wiring Access Cover** - provides access to the internal AC wiring terminal block. This terminal block is used to hardwire all inverter AC input and output wiring connections. Remove the two screws to access the AC wiring terminal block.
- **(16) Input circuit breaker** - this circuit breaker protects the unit's internal charger wiring and pass-thru relay while in the standby mode. This circuit breaker will pop out when it opens, press in to reset. This input circuit breaker is not branch-circuit rated, therefore branch-circuit rated breakers must be installed in the inverter's input wiring.
- **(17) Output circuit breakers** - these circuit breakers are branch-rated and are only provided on the MS2012-15B and MS2012-20B models. They allow the inverter AC loads to be connected directly to the inverter's output without requiring an inverter subpanel. These circuit breakers pop out when they open, press in to reset. They can also be manually pulled to disconnect the inverter's loads.



Info: The output breakers (CB1 and CB2) are only available on models MS2012-15B and MS2012-20B.



CAUTION: Inverter models without the output Circuit breakers (CB1 and CB2) must have branch-circuit rated breakers installed in the inverter's output wiring.



CAUTION: The inverter's internal AC transfer relay is rated for 30 amps per leg (30 amps for AC HOT 1 and 30 amps for AC HOT 2) or 60 amps total. The pass-thru current must be no greater than 30 amps per leg or damage to the relays may occur.

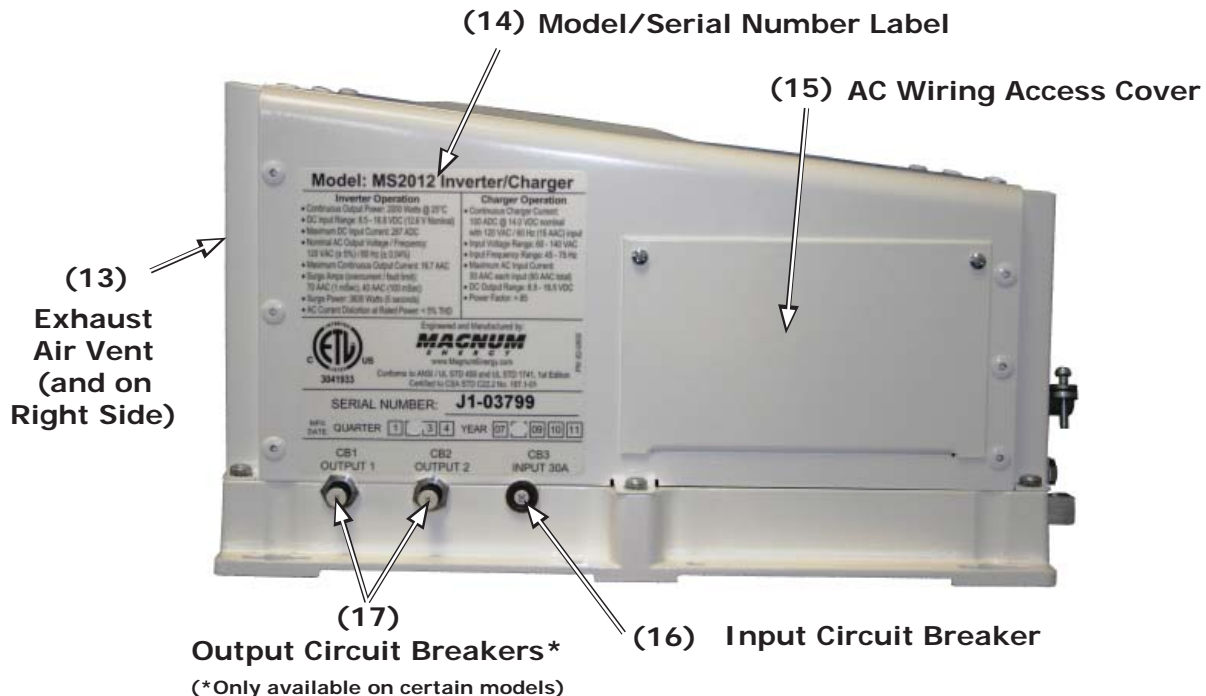

Figure 1-3, Left Side Features

1.2 How an Inverter/Charger Works

There are two modes of operation associated with this inverter/charger:

- **Inverter Mode:**

When the inverter is properly connected to batteries and turned on, the Direct Current (DC) from the batteries is transformed into a pure sine wave Alternating Current (AC). This AC is similar to the voltage provided by your utility and is used to power the electrical appliances (i.e. AC loads) connected to the inverter's output.

- **Standby Mode:**

When an external source of AC power (i.e. utility power or generator) is connected and qualified on the inverter's AC input, it operates in the Standby Mode. In the Standby Mode, the unit operates as a Battery Charger to convert the incoming AC power into DC power to recharge the batteries; and at the same time, automatically closes an internal AC Transfer Relay to pass the incoming AC power directly to inverter's output to continue powering the connected electrical appliances.

1.2.1 Inverter Applications for Permanent Installations

An inverter can be used for backup power in a permanent location that normally uses utility power such as a home or office. When the utility power is available, the inverter keeps the batteries charged. When the utility power fails, the inverter comes on automatically to supply AC power to your home or office during the power failure. For a home or business, reliable backup power is used to prevent lost computer data or to maintain lights and keep food fresh in the refrigerator/freezer.

In some areas, where utility power is not available, this inverter can be used in an stand-alone renewable power system. The inverter allows AC electrical appliances to be run from the storage battery bank. When the battery bank becomes discharged, either renewable DC sources (solar, wind or hydro power) can be used to recharge the batteries or a generator can be connected to the inverter to power the system while the batteries recharge.

1.2.2 Inverter Applications for Mobile Installations

Inverters can also be used to provide power in mobile situations, such as in an RV, truck or boat. In these applications, the inverter provides power to the AC loads using the energy stored in the batteries and recharges the batteries when shore power or onboard generator is available.

1.3 Advantages of a Pure Sine Wave vs Modified Sine Wave Inverter

Today's inverters come in two basic output waveforms: modified sine wave (which is actually a modified square wave) and pure sine wave. Modified sine wave inverters approximate a pure sine waveform and will run most appliances and electronics without any problems. These inverters are less expensive and, therefore, offer a viable alternative to more expensive pure sine inverters.

The output of a pure sine wave inverter is equal to or, in many cases, better than the utility power used in your home. Virtually any electronic device will operate from a pure sine wave inverter. Motors run cooler, microwaves usually cook faster and clocks keep better time just to name a few examples. Without compromising quality or performance, the MagnaSine provides you with all of the advantages of a pure sine wave inverter at a much lower cost than many on the market.

The MS Series is built on the same platform as our popular ME and RD Series modified sine wave inverters allowing for an easy upgrade from the original ME or RD Series installation. This standard platform also helps reduce cost by using standard parts/accessories across many models. All Magnum accessories such as the Remote Control (ME-RC), Automatic Generator Start - Networked (ME-AGS-N), Battery Monitor Kit (ME-BMK), and network accessories can be used on all ME, RD, and MS Series inverters.

Introduction

1.4 Appliances and Run Time

The MS Series inverter/charger can power a wide range of household appliances including small motors, hair dryers, clocks and other electrical devices. As with any appliance using batteries for power, there is a certain length of time that it can run - this is called "run time." Actual run time depends on several variables including the size and the type of appliance, the type of batteries installed in your application, as well as the battery's capacity and age. Other factors such as the battery's state of charge and temperature can also affect the length of time your appliances can run.

Appliances such as TVs, VCRs, stereos, computers, coffee pots, incandescent lights and toasters can all be successfully powered by your inverter. Larger electrical appliances, however, such as stoves, water heaters, etc., can quickly drain your batteries and are not recommended for this application.

All electrical appliances are rated by the amount of power they consume. The rating is printed on the product's nameplate label, usually located on its chassis near the AC power cord. Even though it is difficult to calculate exactly how long an inverter will run a particular appliance, the best advice is trial and error. Your MS Series inverter has a built-in safeguard that automatically protects your batteries from over discharge.



Info: For optimum performance, a minimum battery bank of 200 AH is recommended for moderate loads (<1000W) and greater than 400 AH for heavy loads (\geq 1000W).

Table 1-1, Typical Appliance Power Consumption

Device	Load	Device	Load
Blender	400W	Coffee Maker	1200W
Computer	300W	Color TV	150W
Drill	500W	Hair Dryer	1000W
Hot Plate	1800W	Iron	1000W
Light (Flo)	10W	Light (Inc)	100W
Microwave	1000W	Refrigerator	500W

2.0 Installation



Info: Installations should be performed by qualified personnel, such as a licensed or certified electrician. It is the installer's responsibility to determine which safety codes apply and to ensure that all applicable installation requirements are followed. Applicable installation codes vary depending on the specific location and application of the installation.



CAUTION: Review the "Important Product Safety Information" on page ii and the "Important Battery Safety Instructions" on page iii before any installation.



CAUTION: The inverter is heavy. Use proper lifting techniques during installation to prevent personal injury.

The simplified system diagram shown in Figure 2-1 should be reviewed to assist you in planning and designing your installation. This drawing is not intended to over-ride or restrict any national or local electrical codes. This drawing should not be the determining factor as to whether the installation is compliant, that is the responsibility of the electrician and the on-site inspector.

2.1 Pre-Installation

Before installing the inverter, read the entire installation section to determine how you are going to install your MS inverter/charger. The more thorough you plan in the beginning, the better your inverter needs will be met.

2.1.1 Unpacking and Inspection

Carefully remove the MS Series inverter/charger from its shipping container and inspect all contents. Verify the following items are included:

- The MS Inverter/Charger
- Red and black DC terminal covers with Phillips screws
- AC access cover with two Phillips screws
- Two 5/16" Kep nuts (installed on the DC terminals).
- Battery Temperature Sensor
- Warning Label
- MS Series Owner's Manual

If items appear to be missing or damaged, contact your authorized Magnum Energy dealer or Magnum Energy. If at all possible, keep your shipping box. It will help protect your inverter from damage if it ever needs to be returned for service. Save your proof-of-purchase as a record of your ownership; it will also be needed if the unit should require in-warranty service.

Record the unit's model and serial number in the front of this manual in case you need to provide this information in the future. It is much easier to record this information now, instead of trying to gather it after the unit has been installed.

2.1.2 Required Tools and Materials

Hardware/Materials

- Conduit, strain-reliefs and appropriate fittings
- Electrical tape
- 1/4" mounting bolts and lock washers
- Wire ties

Tools

- Miscellaneous screwdrivers
- Drill and drill bits
- Level
- Pliers
- Pencil or Marker
- 1/2" wrench
- Wire strippers
- Multimeter

Installation

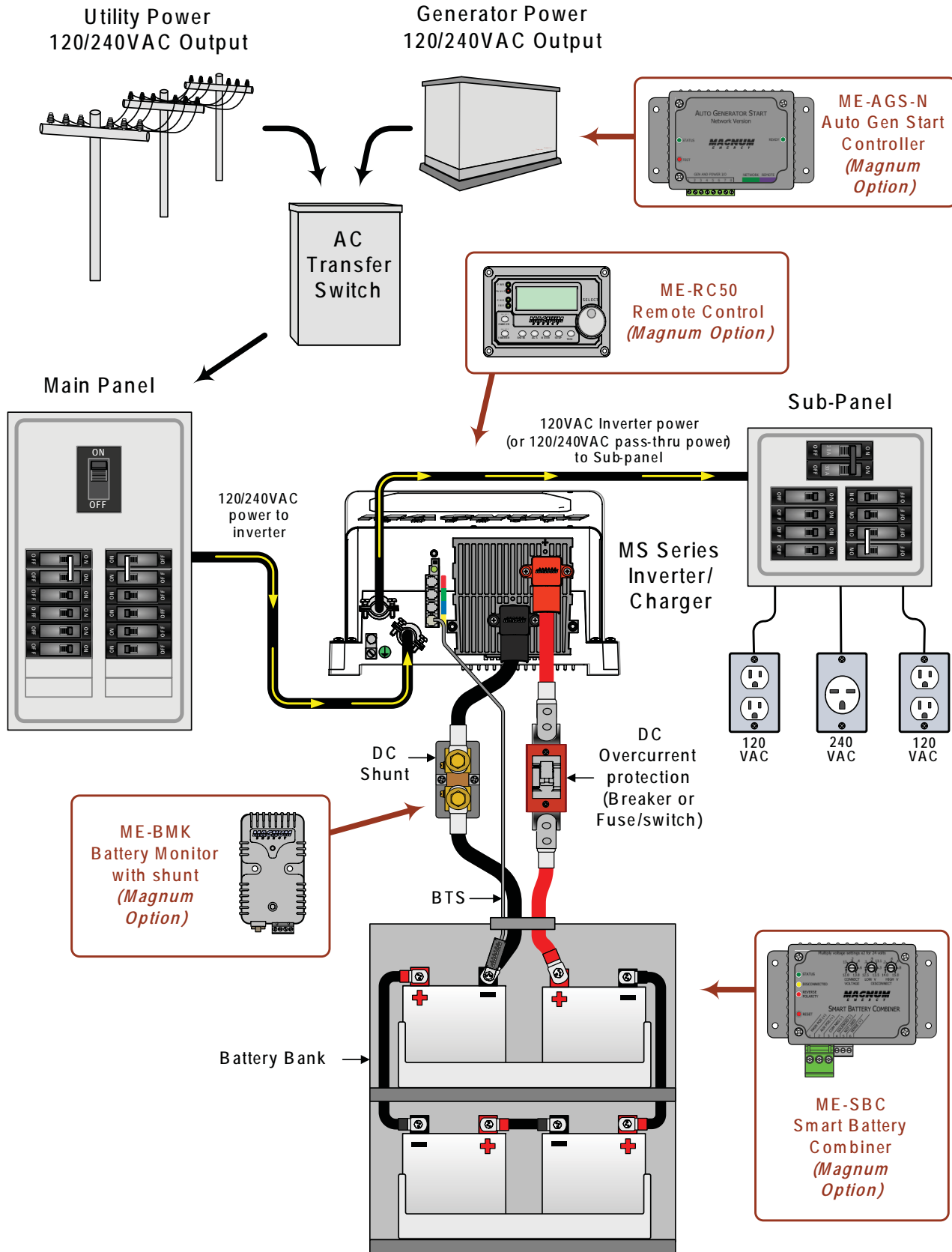

Figure 2-1, Simplified Installation Diagram for Permanent Installations

2.1.3 Locating the Inverter

Only install the inverter in a location that meets the following requirements:

Clean and Dry - The inverter should not be installed in an area that allows dust, fumes, insects or rodents to enter or block the inverter's ventilation openings. This area also must be free from any risk of condensation, water or any other liquid that can enter or fall on the inverter. The inverter uses stainless steel fasteners, plated copper buss-bars, a power-coated aluminum base and the internal circuit boards are conformal coated all done to help fight the harmful effects of corrosive environments. However, the inverter's life is uncertain if used in these type of environments, and inverter failure under these conditions is not covered under warranty.



Info: If the inverter is installed in an area where moisture may occur, we recommend putting silicone dielectric grease compound into the electrical ports (items 3 to 6 as shown in figure 1-1). Before installing the cables or if leaving any ports open, squirt a liberal amount into each port. Silicone dielectric compound makes an effective moisture and corrosive barrier to help protect and prevent corrosion to the RJ11 connections.

Cool - The inverter should be protected from direct sun exposure or equipment that produces extreme heat. The ambient temperature around the inverter must not exceed 77°F (25°C) to meet power specifications.

Ventilation - In order for the inverter to provide full output power and avoid over temperature fault conditions; do not cover or block the inverters ventilation openings or install this inverter in an area with limited airflow. The inverter uses two fans to provide forced air cooling, these fans pull in air through the intake vents (see item 9 in figure 1-2) and blow out air through the exhaust vents (see item 13 in figure 1-3). Allow at the minimum, an airspace clearance of 6" at the intake and exhaust vents and 3" everywhere else to provide adequate ventilation.

If installed in an enclosure, a fresh air intake opening must be provided directly to the front side (intake vents) of the inverter and an exhaust opening on the back side (exhaust vents) of the inverter. This allows cool air from the outside to flow into the inverter and heated air to exit the inverter and out of the enclosure. When mounted in an enclosed compartment, airflow must be ≥ 100 cfm in order to maintain no more than a 68°F (20°C) rise in compartment temperature.



CAUTION: Do not mount this inverter in a zero clearance compartment, cover or obstruct the ventilation openings - overheating may result.

Safe - Keep any flammable/combustible material (i.e., paper, cloth, plastic, etc.) that may be ignited by heat, sparks or flames at a minimum distance of 2 feet away from the inverter. Do not install this inverter in any area that contains extremely flammable liquids like gasoline or propane, or in locations that require ignition-protected devices.



WARNING: The MS Series inverter/charger is not ignition protected and may not be located in an engine compartment with gasoline-fueled engines under any circumstance.

Close to the battery bank - As with any inverter, it should be located as close to the batteries as possible. Long DC wires tend to loose efficiency and reduce the overall performance of an inverter. However, the unit should not be installed in the same compartment as the batteries or mounted where it will be exposed to gases produced by the batteries. These gases are corrosive and will damage the inverter; also if these gases are not ventilated and if allowed to collect, they could ignite and cause an explosion.

Accessible - Do not block access to the inverter's remote control and accessory ports as well as the inverter's controls and status indicator. Also allow enough room to access the AC and DC wiring terminals and connections, as they will need to be checked and tighten periodically. See figure 2-3 for the MS Series inverter/charger dimensions.

Away from sensitive electronic equipment - High powered inverters can generate levels of RFI (Radio Frequency Interference). Locate any electronic equipment susceptible to radio frequency and electromagnetic interference as far away from the inverter as possible.

Installation

2.2 Mounting the Inverter

The inverter base can reach a temperature up to 90°C (194°F), and it is recommended that it should be mounted on a noncombustible surface*. This surface and the mounting hardware must also be capable of supporting at least twice the weight of the inverter. To meet regulatory requirements, the MS Series must be mounted in one of the following positions; as shown in figure 2-2:

- above or under a horizontal surface (shelf or table),
- or on a vertical surface (wall) with the DC terminals to the right.



CAUTION: If the inverter is mounted in a way that the DC terminal ventilation openings are oriented on the bottom, the ME-CB enclosure must be used. This enclosure prevents burning material from falling out the bottom and also allows sufficient ventilation to prevent the inverter from overheating under normal operating conditions.

After determining the mounting position, refer to the physical dimensions as shown in figure 2-3 or use the base of the inverter as a template to mark your mounting screw locations. After marking the mounting screw locations, mount the unit with appropriate mounting hardware.

* Noncombustible surface - A surface made of material that will not ignite, burn, support combustion, or release flammable vapors when subjected to fire or heat as per the ASTM E136 standard. For the most part, these are materials that are largely comprised of inorganic materials such as stone, steel, iron, brick, tile concrete, slate and glass. Common building materials such as gypsum board as well as any paint, wall coverings, and certainly wood will not pass.

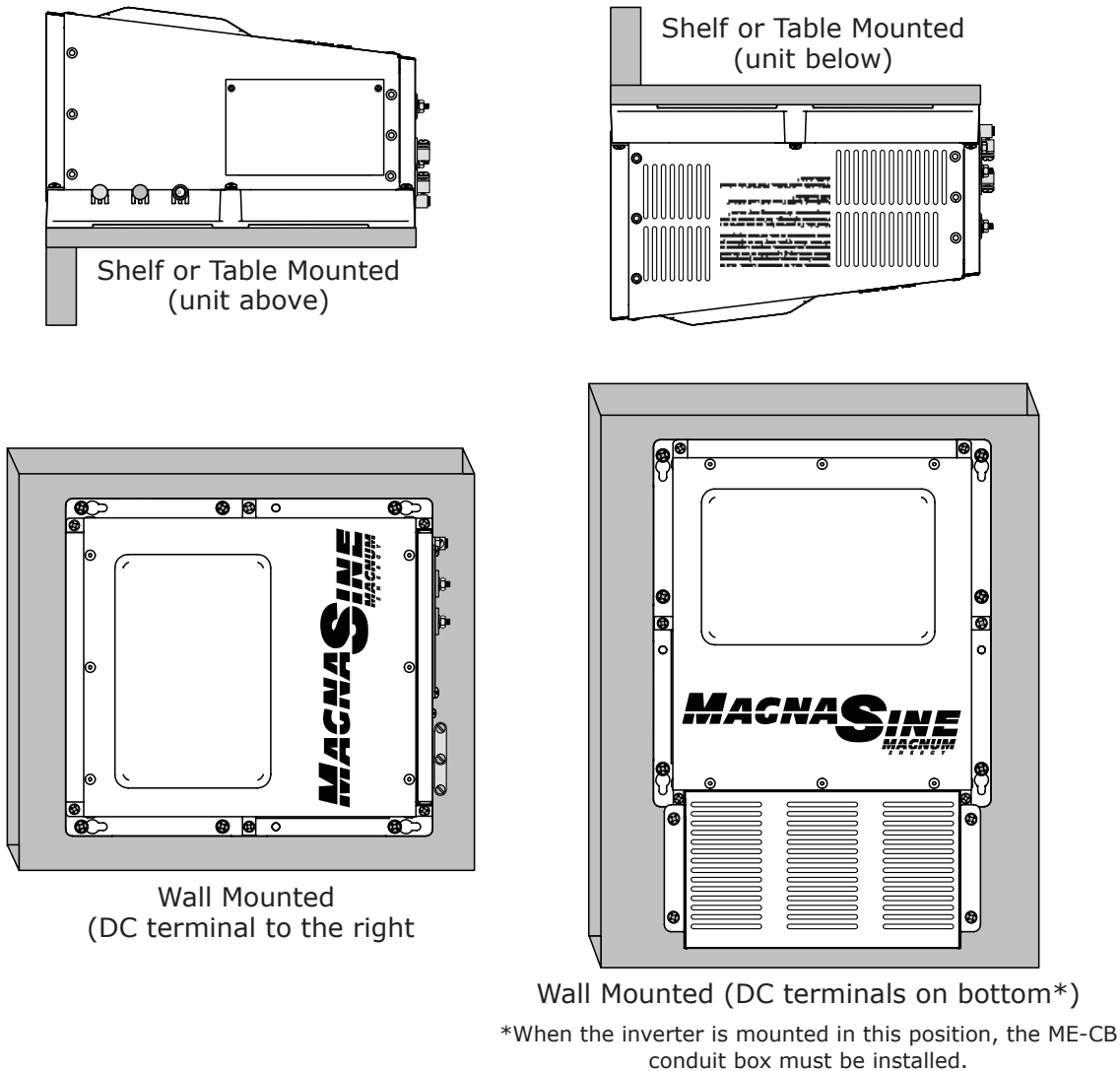

Figure 2-2, Approved Mounting Positions

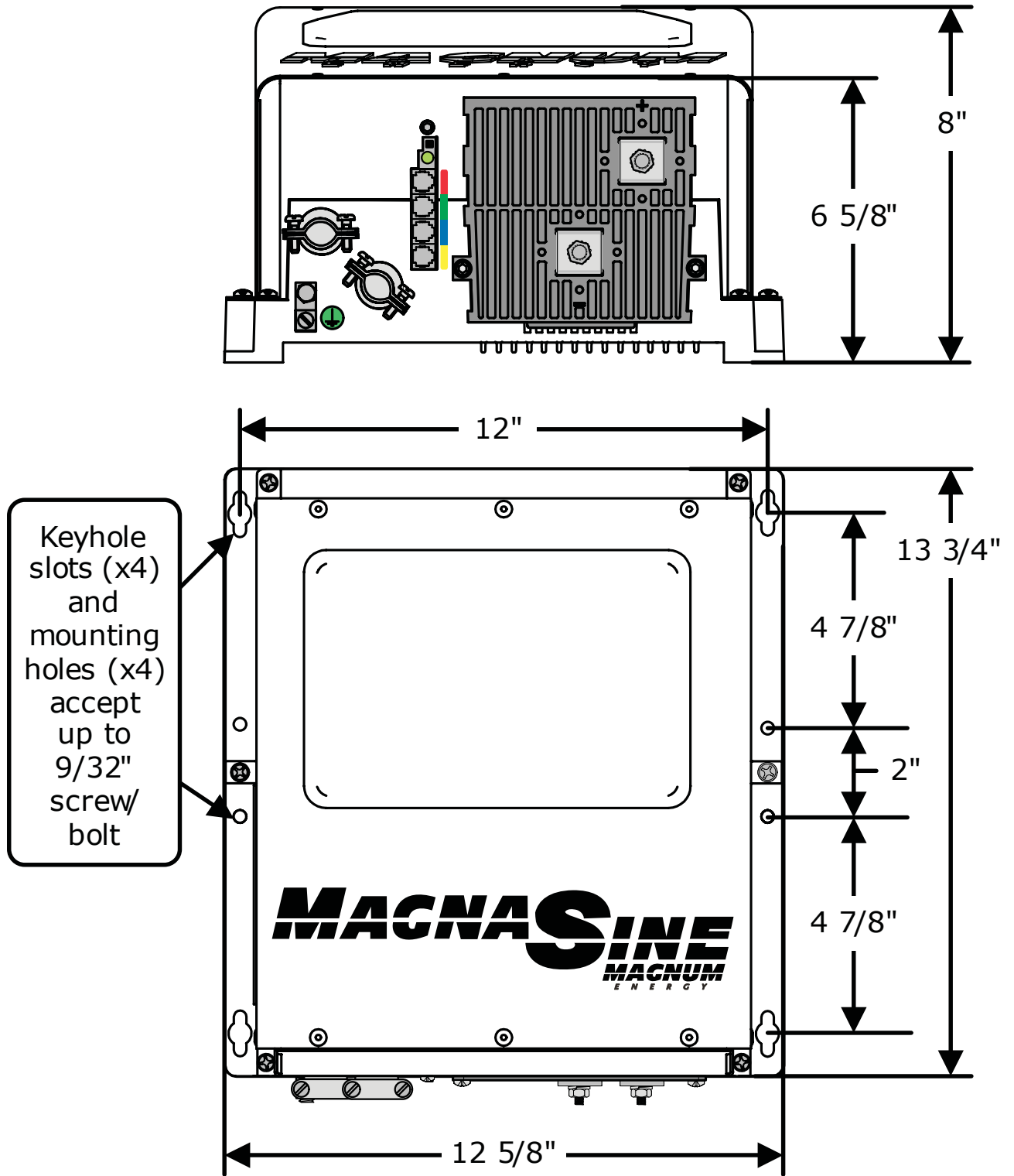

Figure 2-3, MS Series Dimensions

Installation

2.3 Wiring the Inverter - General Requirements

This section also describes the requirements and recommendations for wiring the MS Series inverter/charger. Before wiring the MS Series inverter/charger, read all instructions.

All wiring should meet all local codes and standards and be performed by qualified personnel such as a licensed electrician.

The NEC (National Electric Code, ANSI/NFPA 70) for the United States and the CEC (Canadian Electrical Code) for Canada provide the standards for safely wiring residential and commercial installations. The NEC/CEC lists the requirement for wire sizes, overcurrent protection and installation methods and requirements.

Inverter/charger systems involve power from multiple sources (inverter, generator, utility, batteries, solar arrays, etc.) which make the wiring more hazardous and challenging.

The input and output AC and DC circuits are isolated from the inverter chassis. The inverter system grounding is the responsibility of the installer in accordance with the NEC.



WARNING: Ensure all sources of DC power (i.e., batteries, solar, wind or hydro) and AC power (utility power or AC generator) are de-energized (i.e., breakers opened, fuses removed) before proceeding - to prevent accidental shock.

2.3.1 Protecting Wire - Conduit Box

The AC and DC wires into and out of the inverter must be protected as required by code. This can be done by using jacketed wires or by feeding the wires through conduit. Magnum provides a DC conduit box (part number ME-CB) that can be purchased to allow conduit to be connected to the inverter for both the AC and DC conductors.



Info: If using the ME-CB conduit box and the AC wires are individual conductors (i.e., not jacketed), the strain reliefs can be removed and replaced with 3/4" grommets.

2.3.2 Wiring Requirements

- All conductors that are at risk to physical damage must be protected by conduit, tape, or placed in a raceway.
- Always check for existing electrical, plumbing or other areas of potential damage prior to making cuts in structural surfaces or walls.
- Do not mix AC and DC wiring in the same conduit or panel unless specifically approved/ designed for both AC and DC wiring. Where DC wiring must cross AC or vice-versa, try to make the wires at the crossing point 90° to one another.
- Both AC and DC overcurrent protection must be provided as part of the installation.
- The inverter requires a reliable negative and ground return path directly to the battery.
- Use only copper wires with a minimum temperature rating of 90°C.

2.3.3 Wire Routing

Before connecting any wires, determine all wire routes to and from the inverter. Typical routing scenarios are:

- AC input wiring from the main AC panel to the inverter
- AC input wiring from a generator (optional) to the inverter
- DC input wiring from the batteries to the inverter
- AC output wiring from the inverter to the AC sub-panel or to dedicated circuits
- Battery Temperature Sensor cable from the inverter to the batteries
- Remote Control cable (optional) to the inverter
- Ground wiring to and from the inverter

2.3.4 Torque Requirements

- Torque all AC wiring connections to 16 in lbf (1.8 N-m). Torque DC cable connections from 10 to 12 ft lbf (13.6 to 16.3 N-m).

2.4 DC Wiring

This section describes the inverter's required DC wire sizes and the recommended disconnect/overcurrent protection and how to make the DC connections to the inverter and the battery bank.

Refer to figure 2-4 when connecting the DC wires.



WARNING: Even though DC voltage is "low voltage", significant hazards may be present, particularly from short circuits of the battery system.



CAUTION: The inverter is NOT reverse polarity protected which means that if the negative and positive battery voltage is connected backwards to the inverter, the inverter will likely be damaged. You should verify the correct voltage polarity using a voltmeter BEFORE connecting the DC wires.



CAUTION: Before wiring the DC cables, review the safety information at the beginning of this manual and the following to ensure a safe and long-lived system.



Info: DO NOT connect the battery cables to the inverter until all wiring is complete and the correct DC voltage and polarity has been verified.

- When the inverter is installed in a Photovoltaic System, the NEC requires that the DC circuit conductors and overcurrent devices to the inverter be sized to carry not less than 125% of the inverter's maximum current rating.
- The DC positive and negative cables connected to the inverter from the battery bank should be tied together with wire ties or electrical tape approximately every 6 inches. This helps improve the surge capability and reduces the effects of inductance, which improves the inverter waveform and reduces the wear of the inverter's filter capacitors.
- Crimped and sealed copper ring terminal lugs with a 5/16" hole should be used to connect the DC wires to the inverter's DC terminals.
- The battery bank voltage MUST match the DC voltage required by the inverter (i.e., 24-volt battery bank for a 24-volt inverter) or the inverter may be damaged.
- To ensure the maximum performance from the inverter, all connections from the battery bank to the inverter should be minimized, the exception is the DC overcurrent disconnect in the positive line and a shunt in the negative line. Any other additional connection will contribute to additional voltage drops and these extra connections points may loosen during use.
- All wiring to the battery terminals should be checked periodically (once a month) for proper tightness. The torque requirement for the DC terminals is between 10 to 12 ft lbf (13.6 to 16.3 N-m). If you don't have a torque wrench, ensure all DC terminals are tight and cannot move.
- Be aware that overtightening or misthreading the nuts on the DC terminals can cause the bolts to strip and snap/break off.
- Make sure cables have a smooth bend radius and do not become kinked. Place long cable runs in conduit and follow existing wire runs where possible.
- A brief spark or arc may occur when connecting the battery cables to the inverter DC terminals; this is normal and due to the inverter's internal capacitors being charged.
- Color code the DC cables/wires with colored tape or heat shrink tubing: RED for positive (+); WHITE for negative (-); and GREEN for DC ground to avoid polarity problems.

Installation

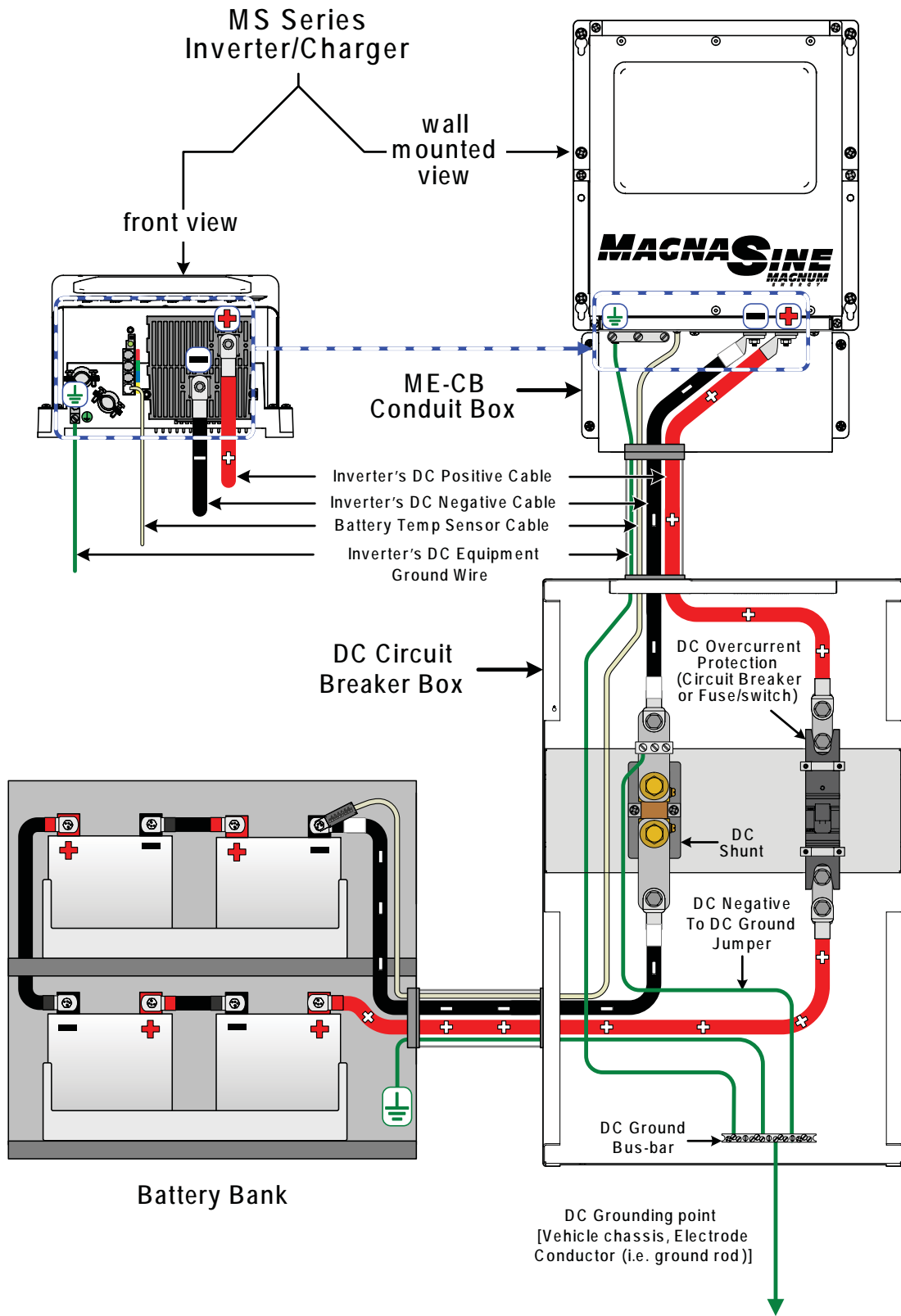

Figure 2-4, DC and Battery Temperature Sensor Wiring

2.4.1 DC Wire Sizing

It is important to use the correct DC wire to achieve maximum efficiency from the system and reduce fire hazards associated with overheating. Always keep your wire runs as short as practical to help prevent low voltage shutdowns and keep the DC breaker from nuisance tripping (or open fuses) because of increased current draw. See Table 2-1 to select the minimum DC wire size (and corresponding overcurrent device) required based on your inverter model. The cable sizes listed in Table 2-1 for your inverter model are required to reduce stress on the inverter, minimize voltage drops, increase system efficiency and ensure the inverter’s ability to surge heavy loads.

If the distance from the inverter to the battery bank is greater than 5 feet, the DC wire will need to be increased. Longer distances cause an increase in resistance, which affects the performance of the inverter. Continue to use the overcurrent device previously determined from Table 2-1 and then refer to Table 2-2 to determine the minimum DC wire size needed for various distances based on your inverter model.

2.4.2 DC Overcurrent Protection

DC overcurrent protection is not included in the inverter and for safety and to comply with electrical code regulations, it must be provided as part of the installation. The DC overcurrent protection device must be installed in the positive DC cable line, can be a fuse or a circuit breaker and must be DC rated. It must be correctly sized according to the size of DC cables being used, which means it is required to open before the cable reaches its maximum current carrying capability, thereby preventing a fire. In a residential or commercial electrical installation, the NEC requires both overcurrent protection and a disconnect switch. If a circuit breaker is used as the overcurrent protection device, it can also be used as the required DC disconnect.

If a fuse is used as an overcurrent device, a Class-T type or equivalent is recommended. This fuse type is rated for DC operation, can handle the high short-circuit currents and has a time delay that allows for momentary current surges from the inverter without opening the fuse. However, because the fuse can be energized from both directions, if it is accessible to unqualified persons, the NEC requires that it be installed in a manner that the power must be disconnected on both ends of the fuse before servicing.

Use Table 2-1 to select the DC overcurrent device needed based on the recommended minimum wire size according to your inverter model. These recommendations may not meet all local code or NEC requirements.

Table 2-1, Recommended DC Wire/Overcurrent Device for Rated Use

Inverter Model	Maximum Continuous Current ¹	NEC Current ²	Using Conduit		In Free Air		DC Grounding Electrode Wire Size ⁵
			Minimum DC Wire Size (rating) ³	Recommended DC Breaker Size ⁴	Minimum DC Wire Size (rating) ³	Maximum DC Fuse Size ⁴	
MS2012	222 amps	278 amps	#4/0 AWG (260 amps)	250 amps ⁶	#2/0 AWG (300 amps)	300 amps with time delay	#6 AWG
MS2812	311 amps	388 amps	#4/0 AWG (260 amps)	250 amps ⁶	#4/0 AWG (405 amps)	400 amps with time delay	#6 AWG
MS4024	222 amps	278 amps	#4/0 AWG (260 amps)	250 amps ⁶	#2/0 AWG (300 amps)	300 amps with time delay	#6 AWG

- Note 1 - Maximum Continuous Current is based on the inverter’s continuous power rating at the lowest input voltage.
- Note 2 - NEC Current is based on the Maximum Continuous Current rating with a 125% NEC de-rating for sizing the overcurrent device (when not continuous duty) to prevent it from being operated at more than 80% of rating.
- Note 3 - Copper wire rated with 90°C (194°F) insulation at an ambient temperature of 30°C (86°F), with a multiple cable fill factor (0.8) de-rating (if needed).
- Note 4 - The next larger standard size overcurrent device may be used if the derated cable ampacity falls between the standard overcurrent devices found in the NEC.
- Note 5 - Per the NEC, the DC grounding electrode conductor can be a #6 AWG conductor if that is the only connection to the grounding electrode and that grounding electrode is a rod, pipe, or plate electrode.
- Note 6 - May not allow continuous operation at full rated power as defined by the NEC.

Installation

Table 2-2, DC Wire Size For Increased Distance

Inverter Model	Minimum Recommended DC Wire Size (one way) *					
	5 feet or less		5 to 10 feet		10 to 15 feet	
	In Conduit	In free air	In Conduit	In free air	In Conduit	In free air
MS2012	#4/0 AWG	#2/0 AWG	#4/0 AWG x2	#4/0 AWG	not recommended	#4/0 AWG x2
MS2812	#4/0 AWG	#4/0 AWG	#4/0 AWG x2	#4/0 AWG x2	not recommended	not recommended
MS4024	#4/0 AWG	#2/0 AWG	#4/0 AWG x2	#4/0 AWG	not recommended	#4/0 AWG x2

* Copper wire rated with 90°C (194°F) insulation at an ambient temperature of 30°C (86°F).

2.4.3 DC Cable Connections

Do not put anything between the DC cable ring lug and the battery terminal post or the flat metal part of the inverter’s DC terminal. When connecting the DC cable to the battery or inverter DC terminals, the cable should be placed directly against the inverter or battery terminals. Incorrectly installed hardware causes a high resistance connection which could lead to poor inverter/charger performance and may melt the cable and terminal connections.

Follow figures 2-5 and 2-6 on how to connect the DC cables and stack the hardware correctly. Tighten the terminal connections from 10 to 12 ft lbf (13.6 to 16.3 N-m).



CAUTION: The DC terminal and Kep nuts are made of stainless steel which have a high likelihood of seizure. To help prevent the bolt and nut from seizing - causing the bolts to strip or snap/break-off - the use of anti-seize lubricant is highly recommended.



Info: If antioxidant grease or spray is used, apply it after all the connections have been made and are properly tighten.



Info: A 1/2-inch wrench or socket is used to tighten the 5/16-18 SAE Kep nuts.

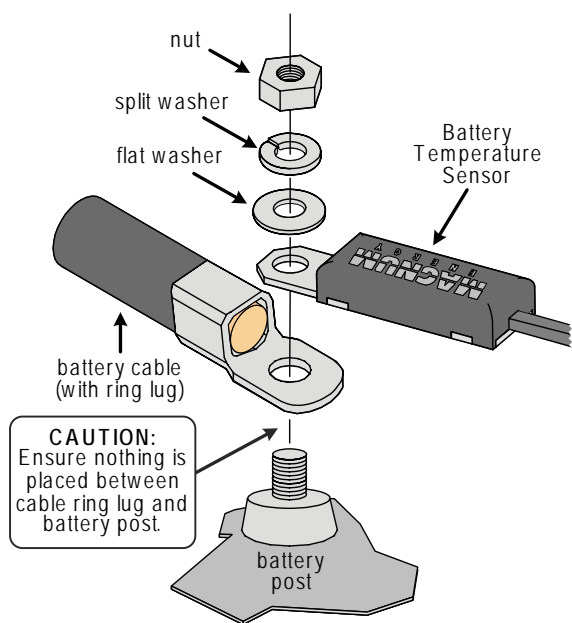

Figure 2-5, Battery Hardware Installation

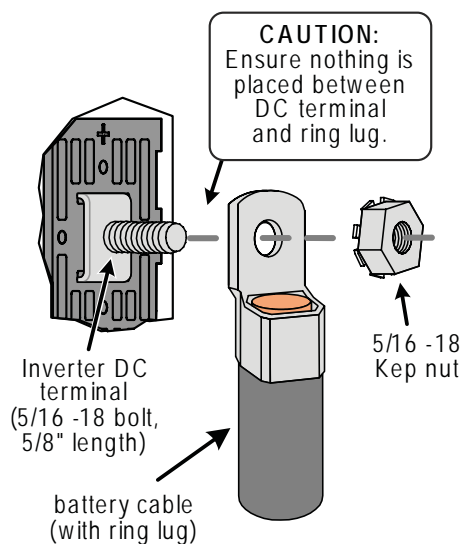

Figure 2-6, Inverter DC Hardware Installation

2.4.4 Wiring the DC Overcurrent Protection Device

A fuse/disconnect or circuit breaker must be provided in the DC positive line between the battery and the inverter to protect the DC wiring system. Mount the fuse block (or circuit breaker assembly) as near as practical to the batteries. For maximum protection, install it within 18 inches (45 cm) of the battery.

1. Open the fuse disconnect (or open the circuit breaker) and connect a short cable (same rating as the battery cables) to one end of the fuse block.
2. Connect the short cable to the positive battery terminal.
3. Connect the positive cable (RED) from the inverter to the fuse/disconnect (or circuit breaker) assembly. DO NOT connect the positive cable to the inverter at this time.
4. Securely tighten the fuse/disconnect (or circuit breaker) connection lugs. Only after the entire installation is complete and all connections are verified, the fuse disconnect (or circuit breaker) will be closed to provide power to the inverter.

2.4.5 Wiring the Battery Bank



WARNING: Lethal currents will be present if the positive and negative cables attached to the battery bank touch each other. During the installation and wiring process, ensure the cable ends are insulated or covered to prevent touching/shorting the cables.



Info: DO NOT connect the DC wires from the battery bank to the inverter until 1) all DC and AC wiring is complete, 2) the correct DC and AC overcurrent protection has been installed and 3) the correct DC voltage and polarity have been verified.



Info: For the MS Series inverter/charger to perform optimally, a minimum battery bank of 200 AH is recommended for moderate loads (<1000W) and greater than 400 AH for heavy loads (≥1000W).

Depending upon the voltage of the batteries you use in the installation (6 or 12 VDC), the batteries must be wired in series, parallel or series-parallel to provide the correct voltage (see Appendix B - Battery Information, for guidance on wiring batteries together). The interconnecting DC wires must be sized and rated exactly the same as those that are used between the battery bank and the inverter.

Place the batteries as close as practical to the inverter, preferably in an insulated and ventilated enclosure. Allow adequate space above the batteries to access the terminals and vent caps (as applicable). Also allow at least 1" of space between the batteries to provide good air flow. DO NOT mount the batteries directly under the inverter.



CAUTION: Install batteries in a well ventilated area. Batteries can produce explosive gasses. For compartment or enclosure installations, always vent batteries to the outside.



Info: To ensure the best performance from your inverter system, batteries should be of the same size, type, rating and age. Do not use old or untested batteries.

Installation

2.4.6 Battery Temperature Sensor Installation and Wiring

The Battery Temperature Sensor (shown in figure 2-7) provides the inverter with precise battery temperature information to automatically adjust the ABSORB and FLOAT charge voltage setpoints. This allows the batteries to be correctly charged under extreme temperature changes.

If the temperature sensor is NOT installed and if the batteries are subjected to large temperature changes, the battery life may be shortened.

The BTS provided may be extended - using a RJ11 connector (female to female) and a standard phone cable with RJ-11 connectors - to a maximum length of 40 feet. However, your inverter to battery cable length should not exceed the recommended distance provided in Table 2-2.

To install the BTS:

1. Attach the ring terminal end of the Battery Temperature Sensor to the negative battery terminal; see figure 2-5 for proper connection to the battery terminal.
2. Route the sensor's cable to the inverter following existing wire runs.
3. Connect the RJ11 connector end of the BTS cable to the yellow labeled BTS port on the inverter (item 6 in figure 1-1).

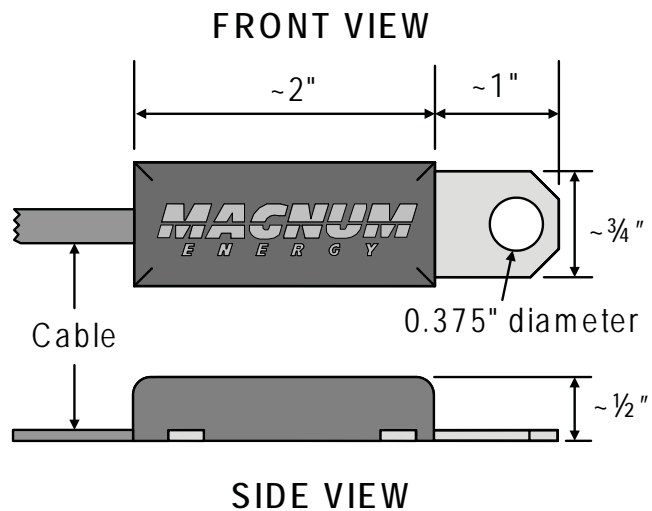

Figure 2-7, Battery Temperature Sensor

2.4.7 Wiring the Inverter to the Battery Bank



CAUTION: Inverter is NOT reverse polarity protected, if this happens the inverter will be damaged and will not be covered under warranty. Before connecting the DC wires from the batteries to the inverter, verify the correct battery voltage and polarity using a voltmeter. If the positive terminal of the battery is connected to the negative terminal of the inverter and vice versa, severe damage will result. If necessary, color code the cables (with colored tape): red for positive (+); white for negative (-) to avoid polarity confusion.



Info: The DC overcurrent device (i.e., circuit breaker or fuse) must be placed in the positive (red) DC cable line between the inverter's positive DC terminal and the battery's positive terminal (red); as close to the battery as possible.

DC Ground Wire

Route an appropriately sized DC grounding wire (green or bare wire) from the inverter's DC equipment ground terminal (item 12 in figure 1-2) to a dedicated system ground. Recommended tightening torque is 45 in lbf (5.1 N-m). Refer to section 2.6 for grounding information and sizing the DC ground wires.

DC Negative Wire

Route an appropriately sized DC negative wire (marked white) from the negative terminal of the battery bank to the inverter's negative terminal (item 11 in figure 1-2).



Info: If installing a battery monitor such as Magnum's ME-BMK, install a DC shunt in-line with the negative battery cable.

DC Positive Wire

Mount the circuit breaker or fuse assembly as near as practical to the batteries and leave open (i.e., no power to inverter).



WARNING: DO NOT close the DC circuit breaker or connect the fuse to connect battery power to the inverter at this time. This will occur in the **Functional Test** after the installation is complete.



CAUTION: If connecting live battery cables to the inverter DC terminals, a brief spark or arc may occur; this is normal and due to the inverter's internal capacitors being charged.

Route and connect an appropriately sized DC positive wire (red) from the inverter's positive DC terminal (item 10 in figure 1-2) to one end of circuit breaker (or DC fuse block).

Connect a short wire (same rating as the DC wires) to the other side of the DC circuit breaker (or one end of the fuse/disconnect assembly) and the other end of the short wire to the positive terminal of the battery bank (see figure 2-1 for reference). This is essential to ensure even charging and discharging across the entire battery bank.

Ensure the DC wire connections (on the batteries, inverter and DC circuit breaker/fuse lugs) are flush on the surface of the DC terminal's and the hardware (lock washer and nut) used to hold these connections are stacked correctly (see figures 2-5 and 2-6). Verify all DC connections are torqued from 10 to 12 ft lbf (13.6 to 16.3 N-m).

Once the DC connections are completely wired and tested, coat the terminals with an approved anti-oxidizing spray.

Attach the red and black terminal covers over the inverter's DC connectors and secure them in place with the supplied screws.

If the batteries are in an enclosure, perform a final check of the connections to the battery terminals, then close and secure the battery enclosure.

Installation

2.5 AC Wiring

This section provides information on how to make the AC connections to the inverter using the correct AC wire size and corresponding overcurrent protection.

2.5.1 Pre-AC Wiring Requirements



CAUTION: Before installing any AC wiring, review the safety information at the beginning of this manual and the following to ensure a safe and long-lived system:

- Read all instructions and cautionary markings located at the beginning of this manual and in the pre-installation section, before installing the inverter and batteries.
- Always use properly rated circuit-breakers. If using an electrical sub-panel, circuit breakers can be moved from the main electrical panel to the sub-panel only if the breakers are also listed to be installed in the sub-panel.
- AC wiring must be no less than #10 AWG (5.3 mm²) gauge copper wire and be approved for the application (i.e., residential, RV or Marine wiring).
- DO NOT connect the inverter's output to an AC power source. This could cause severe damage to the inverter and is not covered under warranty.



WARNING: To reduce the risk of fire, do not connect this inverter to an AC load center (circuit breaker panel) having multi-wire branch circuits connected.

2.5.2 AC Wire Size and Overcurrent Protection

The AC input and output wiring must be sized per the local electrical safety code requirements to ensure the wires ability to safely handle the inverter's maximum load current. After determining the proper AC wire sizes, they are required to be protected from short circuits and overloads by an overcurrent protection device and have a means to disconnect the AC circuits.

The MS Series provides a terminal block (see figure 2-10) that allows the AC input and output wiring to be permanently wired. This terminal block allows a service/distribution panel (main panel) to be wired to the inverter's input and a dedicated panel (sub-panel)¹ between the inverter's output wiring and the AC loads. These systems use the circuit breakers provided in the panels as the overcurrent protection and the AC disconnect device.

AC overcurrent protection is not included in the inverter and must be provided as part of the inverter installation. The AC overcurrent protection device must be a circuit breaker or a fuse/disconnect and be properly sized and branch circuit rated for the wire it is protecting and the appliances being powered.

When in the Standby mode, the full AC continuous pass-thru capacity of the MS Series inverter/charger is 30 amps for each AC leg² (AC HOT 1 and AC HOT 2), However the AC HOT 1 and AC HOT 2 may be combined to obtain a 60 amps pass thru capability (see figure 2-12 for the SISO-60A configuration). For a 30 amp continuous pass-thru capability, each AC HOT input to the inverter requires a 30 amp continuous duty rated breaker³, which corresponds to a minimum cable size of #10 AWG⁴ in conduit. When tying the AC HOT 1 and HOT 2 together for a 60 amp continuous pass-thru capability, the AC input to the inverter requires a 60 amp continuous duty rated breaker³, which corresponds to a minimum cable size of #6 AWG⁴ in conduit. If you are using other circuit breakers/wire sizes, refer to the appropriate electrical codes for proper sizing requirements.



CAUTION: The inverter's internal AC transfer relay contacts are rated for 30 amps (each leg), the pass-thru current for relay contact must be no greater than 30 amps or damage to this relay may occur.

Note 1 - Breaker models (-15B and -20B) do not require a dedicated inverter panel (i.e. sub-panel).

Note 2 - On breaker models (-15B and -20B), the pass-thru current is limited by the output breaker size.

Note 3 - The breaker must be derated by 80% if not rated for continuous duty. The NEC requires that circuits are not to be operated continuously at more than 80% of rating unless listed with a 100% continuous rating.

Note 4 - Copper wire should be rated with 90°C insulation at an ambient temperature of 30°C (86°F).



Figure 2-8, MS Series Inverter/Charger - AC Wiring

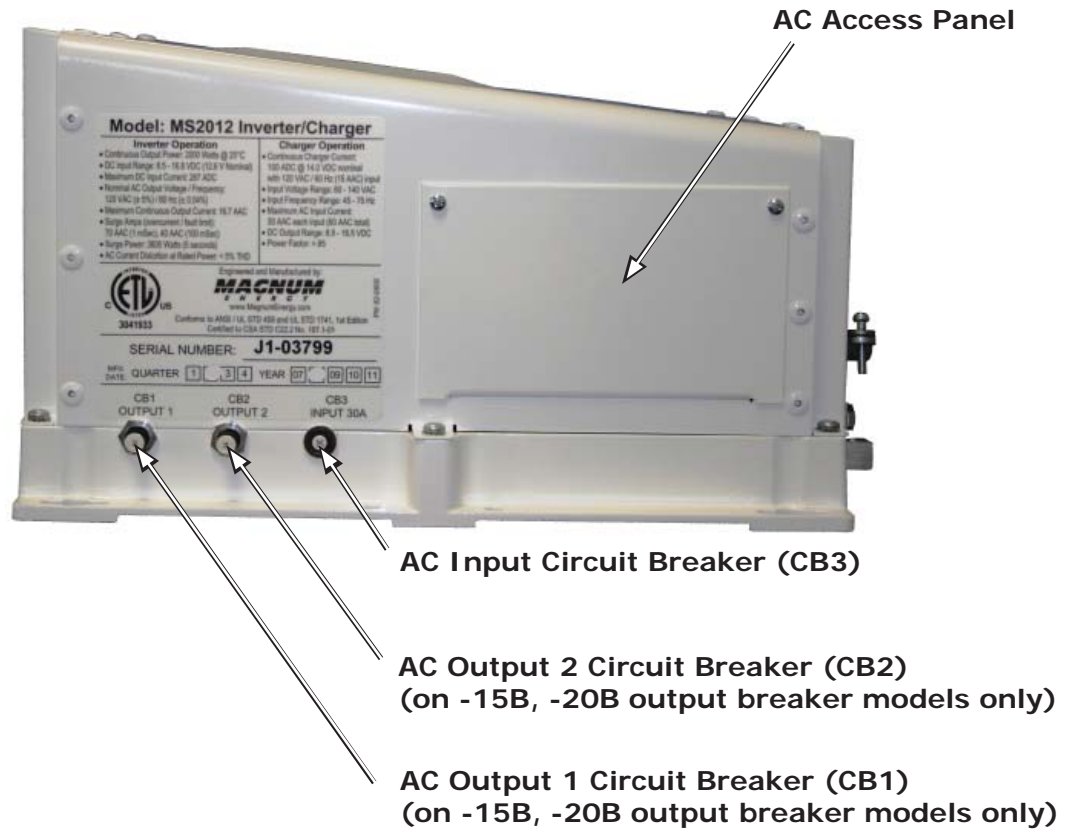

Figure 2-9, MS Series Inverter/Charger - AC Wiring (Access Panel)

Installation

2.5.3 Recommended GFCI (Ground Fault Circuit Interruption) Breakers

Some electrical safety codes require the use of GFCI's. In compliance with UL standards, Magnum Energy has tested the following GFCI's and find that they function properly when connected to the inverter's AC output:

Shock Sentry™ #XGF15V-SP
Leviton Smart Lock #8899-A
Hubbel #GF520EMBKA

2.5.4 AC Terminal Block Connections

The inverter has a six-pole AC terminal block and one AC ground terminal to connect the inverter's AC input and output wiring. To access and view the AC terminal block and ground terminal, remove the two Phillips screws holding the AC wiring access cover plate (see figure 1-3, item 15).

Each connection on the AC terminal block is rated to accept one #14 to #6 AWG (2.1 to 13.3 mm²) CU stranded wire; or two #12 AWG (3.3 mm²) CU stranded wires. Each connection uses a M3.5, slotted head screw and the maximum tightening torque is 16 lbf-in (1.8 N-m).



Info: One of the AC wiring configurations [SI/SO (60A), figure 2-12] uses a #6 AWG wire to carry 60 amps and splits to two wires to allow 30 amps for each leg (i.e. AC HOT 1 and AC HOT 2). IDEAL Industries Inc. (www.idealindustries.com) manufactures a crimp connector (PN: 412) and a separate insulator (PN: 417) that will allow up to two #8 AWG wires with one #6 AWG wire to be connected together.



Info: For marine installations and to comply with ABYC requirements, the six-pole AC terminal is provided with a stainless steel wire protector to prevent wire damage from the set-screw.



Info: The inverter's NEUT IN and NEUT OUT terminals are electrically isolated from each other while inverting. This is related to the neutral-ground bonding requirement and helps to prevent ground-loops (see section 2.6.4 for more information). If the installation requires the input and output neutrals to be connected together, the Inverter's neutral-to-ground connection must be disconnected (see section 2.6.5).

The AC ground terminal can accept one #14 to #6 AWG (2.1 to 13 mm²) CU stranded wire. It uses a slotted head screw and has a recommended maximum tightening torque of 45 lbf-in (5.1 N-m). For multiple ground wires, use a pressure or mechanical connector to attach the single wire from the AC ground terminal to the input and output ground connections.

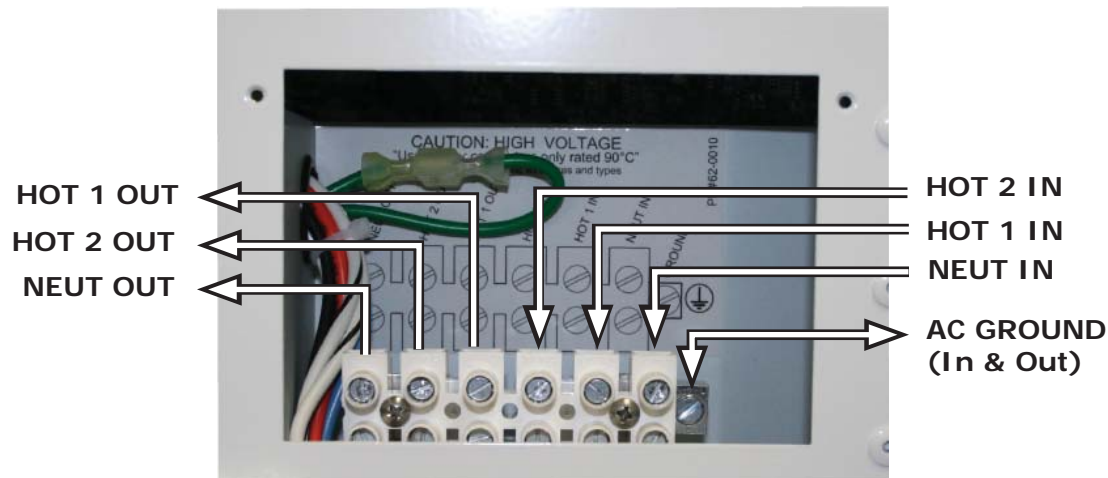

Figure 2-10, AC Terminal Block

2.5.5 AC Conductor Wiring

The following steps are basic guidelines for installing and connecting the AC wiring into and out of the inverter, refer to table 2-3 to determine your AC wiring configurations before beginning.



WARNING: Before making any AC connections, make sure the inverter is disconnected from the battery and all AC power is disconnected from the inverter.

Wiring the Inverter AC Input

1. Remove the two Phillips screws on the AC wiring access cover (item 15 in figure 1-3) to access the internal AC terminal block (see figure 2-10).
2. Route the cable from the AC electrical main panel through one of the strain reliefs clamps to the AC INPUT. Tighten the strain relief clamp securely on the cable. Always leave a little extra slack in the wiring.
3. Connect the hot wire (BLACK) from the main panel's dedicated breaker to the "HOT 1 IN" terminal. Tighten the "HOT 1 IN" terminal to 16 in lbf (1.8 N-m).



Info: Depending on the AC wiring configuration, you may need to connect a wire to the "HOT 2 IN" terminal, refer to your configuration drawing (Figure 2-11 to 2-15).

4. Connect the neutral (WHITE) from the main panel's neutral bus bar to the "NEUT IN" terminal. Tighten the "NEUT IN" terminal to 16 in lbf (1.8 N-m).

Wiring the Inverter AC Output

1. Route the cable from the inverter's AC OUTPUT to the AC electrical sub-panel (or outlets, if using the output breaker versions) through the strain reliefs clamps. Tighten the strain relief clamp securely on the cable.
2. Connect the hot (BLACK) wire from the "HOT 1 OUT" terminal to the sub-panel main breaker (or to the hot connections on the outlets, if using the output breaker versions). Tighten the "HOT 1 OUT" terminal to 16 in lbf (1.8 N-m).



Info: Depending on the AC wiring configuration, you may need to connect a wire to the "HOT 2 OUT" terminal, refer to your configuration drawing (Figure 2-11 to 2-15).

4. Connect the neutral (WHITE) from the "NEUT OUT" terminal to the sub-panel's neutral bus bar (or to the neutral connection on the outlets, if using the output breaker versions). Tighten the "NEUT OUT" terminal to 16 in lbf (1.8 N-m).

Wiring the Inverter AC Ground

5. Combine the ground (GREEN) wire from the main panel's ground bus bar and the ground (GREEN) wire from the sub panel's ground bus bar (or the ground connection on the outlets, if using the output breaker versions). After these grounds are combined, connect them to the "AC GROUND" terminal. Tighten the "AC GROUND" terminal to 16 in lbf (1.8 N-m).

AC Wiring Inspection

1. Verify all cables runs are secured. If installed in a mobile installation - use wire ties or other non-conductive fasteners to prevent chafing or damage from movement and vibration.
2. Verify strain reliefs or grommets are in place to prevent damage to the wiring or conduit where it passes through walls/bulkheads or other openings.
3. After verifying all AC connections are correct and all inverter AC terminal screws are torqued to 16 in lbf (1.8 N-m), replace the AC wiring access cover and the covers on the main electrical/distribution panel.

Installation

2.5.5 AC Wiring Configurations

The following table provides the different wiring configurations for installing and connecting the AC conductors into and out of the inverter (refer to figures 2-11 to 2-15 for installation drawings showing these configurations).

Table 2-3, AC Input/Output Wiring Configurations

	SI/SO (30A) Single In/ Single Out (30A)	SI/SO (60A) Single In/ Single Out (60A)	SI/DO Single In/ Dual Out	DI/SO Dual In/ Single Out	DI/DO Dual In/ Dual Out
AC Source¹ Required	120 VAC @ ≤ 30 amps	120 VAC @ > 30 amps (60 amps maximum).	120/240 VAC (or 2 separate legs of 120 VAC) @ ≤ 15 amps per leg (-15B models); or ≤ 20 amps per leg (-20B models).	120/240 VAC (or 2 separate legs of 120 VAC) @ ≤ 30 amps per leg	120/240 VAC (or 2 separate legs of 120 VAC) @ ≤ 30 amps per leg
Reason to Use	Have an 120 VAC source that is ≤ 30 amps. Requires a separate inverter sub-panel.	Have an 120 VAC source that is > 30 amps. Requires a separate inverter sub-panel.	Do not want to install a separate inverter sub-panel. Inverter pass-thru capability limited by model used: -15B = 30 amps; -20B = 40 amps.	Want dedicated charging and dedicated pass- thru while the AC source is on. Requires a separate inverter sub-panel.	May need to power 240 VAC loads when AC source is on (requires 120/240 VAC source). Requires a separate inverter sub-panel.
Appropriate Models	MS2012 MS2812 MS4024	MS2012 MS2812 MS4024	MS2012-20B MS2012-15B	MS2012 MS2812 MS4024	MS2012 MS2812 MS4024
Maximum Input Breaker Required - Minimum Wire Size	30A (single pole) - #10 AWG (In & Out)	60A (single pole) - #6 AWG (In & Out); Can be split to two #10 AWG (for HOT 1 & HOT 2)	-15B models: 30A (single pole); -20B models: 40A (single pole) - #10 AWG (In) (Hot input must be split to two #12 AWG); #12 AWG x2 (Out)	30A (dual pole) - #10 AWG (In & Out)	30A (dual pole) - #10 AWG (In & Out)
Maximum Inverter Pass-thru capacity	3600W (30A @ 120 VAC)	7200W (60A @ 120 VAC)	-15B models: 3600W (30A @ 120 VAC); -20B models: 4800W (40A @ 120 VAC);	3600W (30A @ 120 VAC)	7200W (2 legs of 30A @ 120/240 VAC or 2 legs of 30A @ 120 VAC) ²
Wiring Diagram	Figure 2-11	Figure 2-12	Figure 2-13	Figure 2-14	Figure 2-15

Note 1: AC Source is from either the utility/grid power (i.e., shore power) or an AC generator.

Note 2: If 2 legs of 30A @ 120 VAC are used, they must be from the same source.

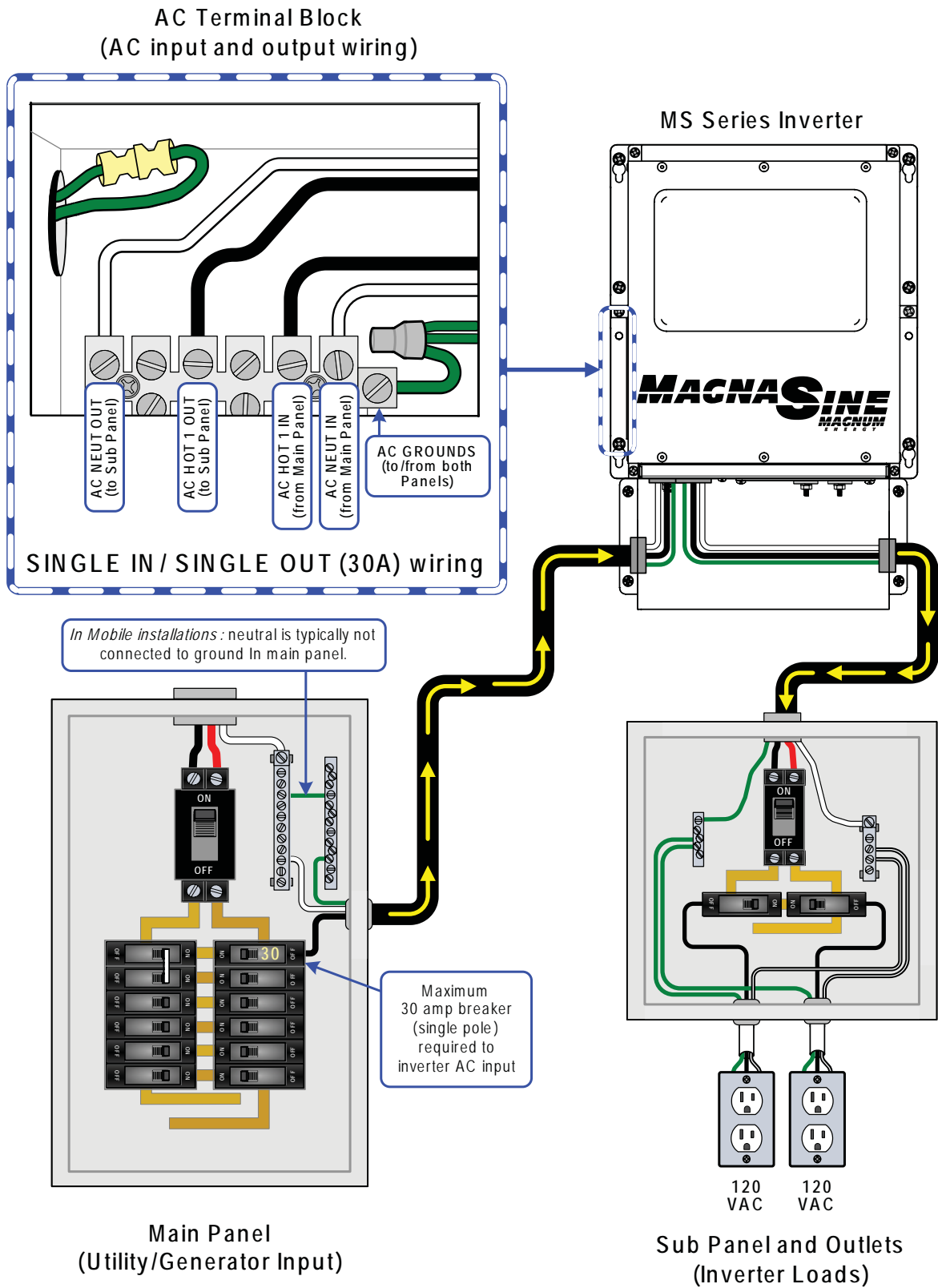

Figure 2-11, AC Wiring for Single In - Single Out (30 A) Configurations

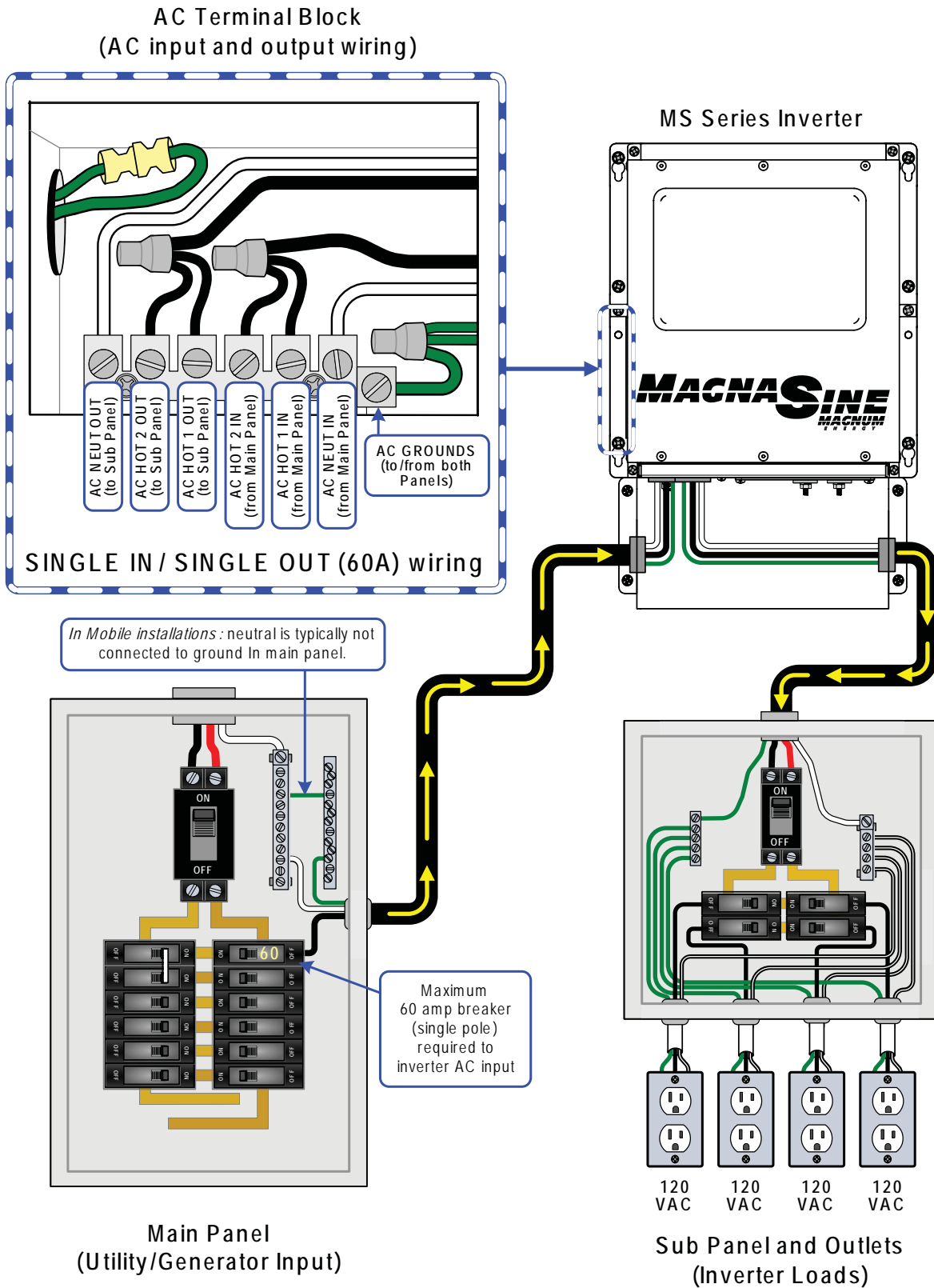

Figure 2-12, AC Wiring for Single In - Single Out (60 A) Configurations

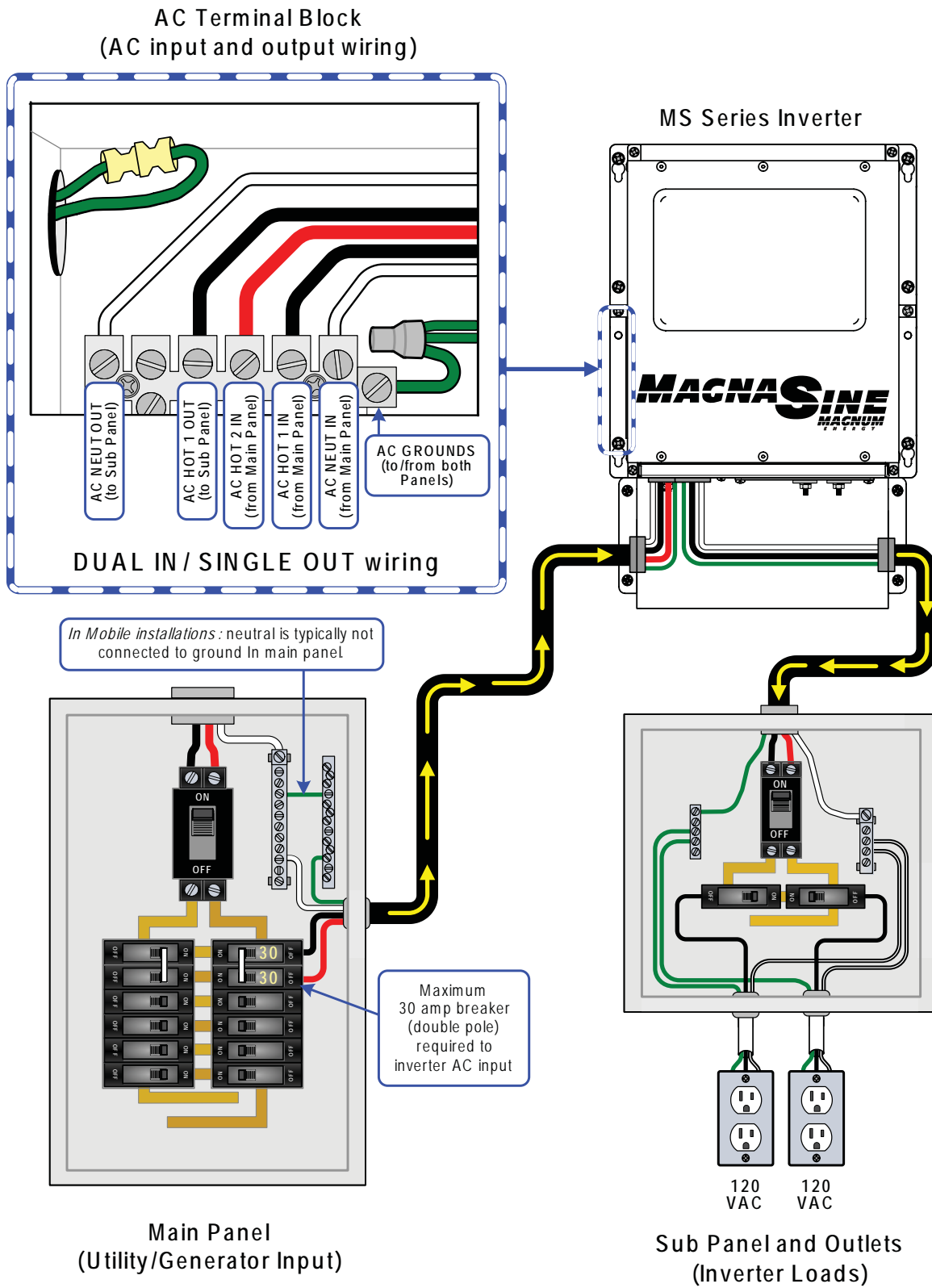

Figure 2-14, AC Wiring for Dual In - Single Out Configurations

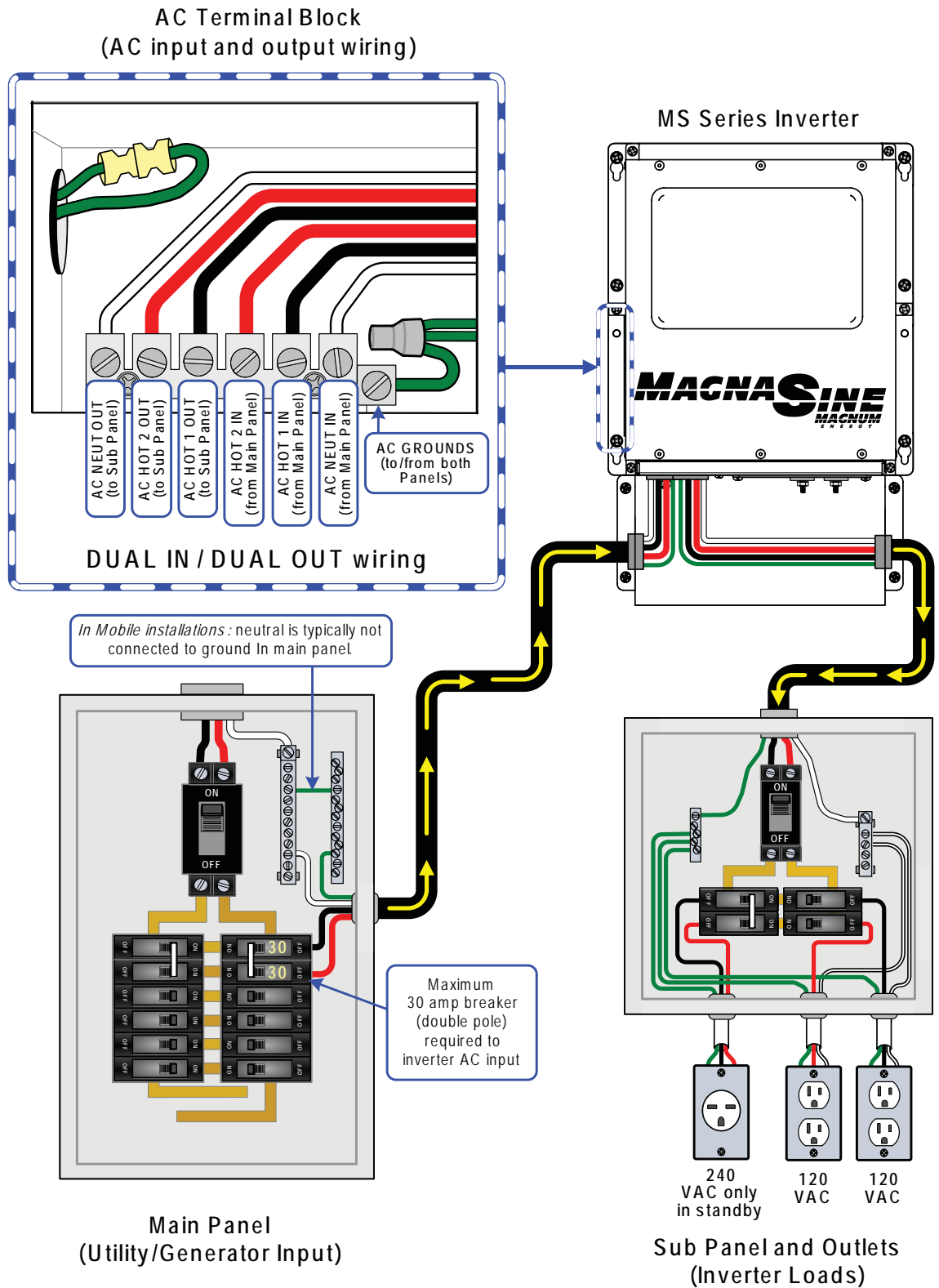

Figure 2-15, AC Wiring for Dual In - Dual Out Configurations

Installation

2.6 Grounding Inverters

The inverter/charger should always be connected to a permanent, grounded wiring system. An inverter system that is properly grounded will limit the risk of electrical shock, reduce radio frequency noise from the inverter and minimize excessive surge voltages induced by lightning. This is done by ensuring there is a well-defined, very low-resistance path from the electrical system to the grounding system. This low-resistance path helps stabilize the electrical system voltage with respect to ground and carries fault currents directly to ground if the electrical system malfunctions.

To understand how the conductors in the electrical circuit will be connected to the system ground, the following terms should be understood:

- **Grounded Conductor (GC):** The wire/cable in the electrical system that normally carries current (usually the AC neutral and/or the DC negative); and is intentionally connected or "bonded" to the ground system. This wire or the ends of this wire should be colored white or gray.
- **Equipment Grounding Conductor (EGC):** A wire/cable that does not normally carry current and is used to connect the exposed metal parts of equipment - that might be accidentally energized - to the grounding electrode system or the grounded conductor. This wire or the ends of this wire should be green or green with a yellow stripe; or this wire can be bare copper.
- **Grounding Electrode Conductor (GEC):** The wire/cable that does not normally carry current and connects the grounded conductor and/or the equipment grounding conductor to the grounding electrode at the service equipment.
- **Grounding Electrode (GE):** A ground rod or conducting element that establishes an electrical connection to the earth.
- **System bonding jumper (SBJ)** The connection between the grounded circuit conductor in the electrical system and the equipment grounding conductor at a separately derived system.

The MS Series inverter/charger uses both AC and DC power; however the AC electrical system is isolated from the DC electrical system by an internal transformer. Although this inverter/charger has two electrical systems, each electrical system **must** be properly grounded and connected to a common "earth" reference; refer to figure 2-16.

For proper grounding, each electrical system must connect all exposed metal parts of equipment (via Equipment Grounding Conductors - EGC) and one of the current-carrying conductors (Grounded Conductor - GC) together at a common point (Ground Bus-Bar - GBB) usually by a System Bonding Jumper (SBJ) in an electrical service disconnect panel. The common point of each electrical system is then connected (via Grounding Electrode Conductor - GEC) to the common ground reference, such as a ground rod (Grounding Electrode - GE). This connection to earth should only be made at one point in each electrical system; otherwise, parallel paths will exist for the currents to flow. These parallel current paths would represent a safety hazard and are not allowed in installations wired per the NEC/CEC.

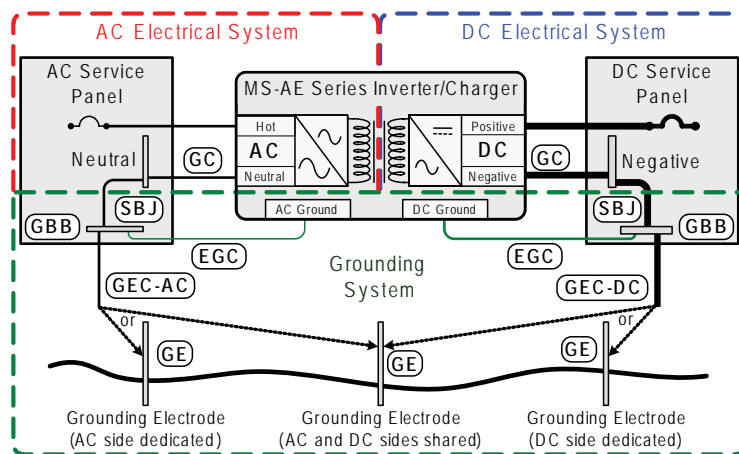

Figure 2-16, Grounding System for MS Series

2.6.1 Sizing the Grounding Electrode Conductors

AC Side - The size of the AC Grounding Electrode Conductor (GEC -AC) depends on the size of the largest ungrounded conductor feeding the AC load center. One #8 AWG (8.4 mm²) copper conductor will serve as an AC Grounding Electrode Conductor (GEC -AC) for AC power conductors smaller than and including #2 AWG (33.6 mm²) copper. See Table 2-4 for additional values.

Table 2-4, AC Grounding Electrode Conductor Sizing

Size of Largest Ungrounded Conductor	Minimum Size of Grounding Electrode Conductor
#2 AWG or smaller	#8 AWG (8.4 mm ²)
#1 to #1/0 AWG	#6 AWG (13.3 mm ²)
#2/0 or #3/0 AWG	#4 AWG (21.1 mm ²)
Over #3/0 AWG through 350 kcmil	#2 AWG (33.6 mm ²)

DC Side - To size the DC Grounding Electrode Conductor, you must first determine which one of the following three methods will be used to connect the DC and AC grounding points in the inverter's two electrical systems to the common "earth" ground:

Method 1 (see figure 2-17): This method uses a separate Grounding Electrode for the DC system and the AC system. In this method - since there are multiple connections to the DC Grounding Electrode (GEC - DC) - the size of the DC Grounding Electrode Conductor cannot be smaller than the largest conductor in the DC system (usually the battery-to-inverter cable).

The DC Grounding Electrode (GE - DC) must be bonded to the AC Grounding Electrode (GE - AC) to make a grounding electrode system; this bonding conductor (BC) cannot be smaller than the largest Grounding Electrode Conductor, either AC or DC.

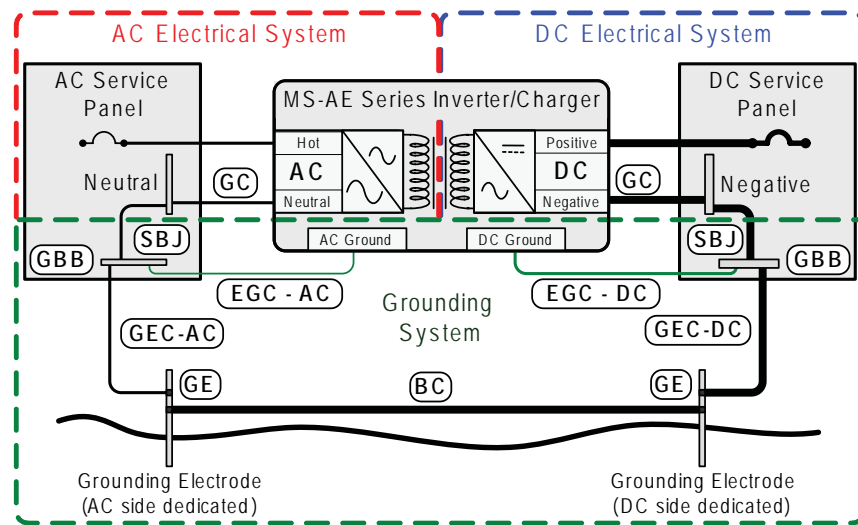

Figure 2-17, Multiple Connections to DC Ground Rod (Method 1)

Installation

Method 2 (see figure 2-18): When the AC and DC service panels are near each other, then the AC Grounding Electrode Conductor (GEC – AC) and DC Grounding Electrode Conductor (GEC – DC) can be connected to a single Grounding Electrode. In this method - since there are multiple connections to the DC Grounding Electrode (GEC – DC) - the size of the DC Grounding Electrode Conductor can not be smaller than the largest conductor in the DC system (usually the battery-to-inverter cable).

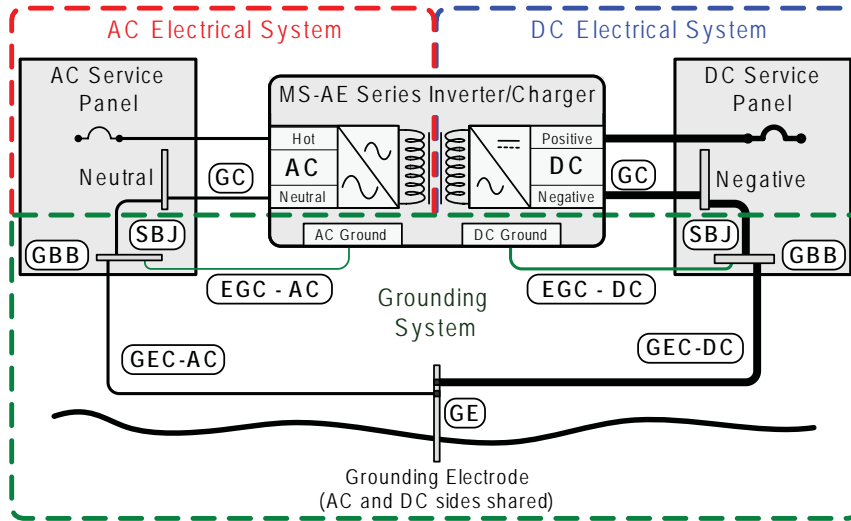

Figure 2-18, Multiple Connections to DC Ground Rod (Method 2)

Method 3 (see figure 2-19): The AC Grounding Electrode Conductor (GEC – AC) is bonded to the DC ground point and the DC Grounding Electrode Conductor (GEC – DC) is the *only connection* to the Grounding Electrode, which must be a rod, pipe, or plate electrode.

In this method, since there is only one connection to the ground rod, the DC Grounding Electrode Conductor is not required to be larger than #6 AWG (13 mm²) copper. The reasoning for allowing this smaller grounding electrode conductor is that it is only required to stabilize the system voltage with respect to earth and the other properly-sized conductors in each electrical system will safely carry any fault currents if they occur.

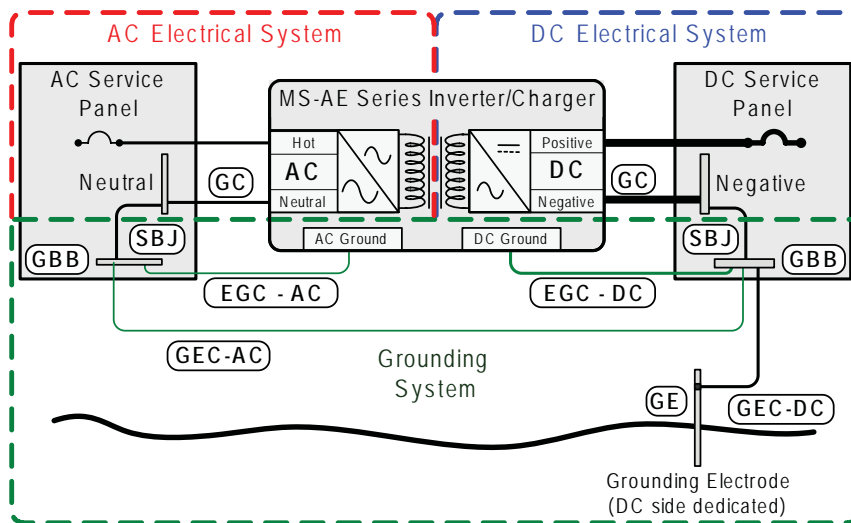

Figure 2-19, Single Connection to DC Ground Rod (Method 3)

2.6.2 System Bonding Jumper

The MS Series inverter does not include an internal bond between the Grounded Conductor (AC neutral/DC negative) and the equipment grounding terminals. This bond [System Bonding Jumper (SBJ)] is usually done in the main distribution panel for each electrical system.



CAUTION: There should be one and only one point in each electrical system (both AC and DC) where the Grounded Conductor is attached to the Grounding Electrode Conductor.

AC Side – The size of the System Bonding Jumper (SBJ) in the AC electrical system is based on the area of the largest AC ungrounded conductor. In accordance with the NEC, use Table 2-4 to determine the System Bonding Jumper size compared to the largest AC ungrounded conductor.

DC Side - The size of the System Bonding Jumper (SBJ) in the DC electrical system must not be smaller than the DC Grounding Electrode Conductor (GEC – DC) used, which is determined from the grounding method that will be used (see section 2.6.1).

2.6.3 Equipment Grounding Conductor

The inverter case and all other non-current-carrying exposed metal surfaces in the entire electrical system that may be accidentally energized must be grounded. The equipment-grounding conductor must be sized to safely carry the maximum ground-fault current likely to be imposed on it from where a ground-fault may occur. In accordance with the NEC, use Table 2-5 to size the equipment-grounding conductors. This table requires that the equipment-grounding conductor be sized according to the rating of the overcurrent device protecting the circuit.



CAUTION: The connections and wiring for the equipment-grounding conductor must be continuous to allow fault currents to properly operate overcurrent devices. Where equipment is removed and this disconnects the bonding connection between the grounding electrode conductor and exposed conducting surfaces, a bonding jumper must be installed while the equipment is removed.

AC Side - Where the AC output from the inverter is connected to an AC load center, there should be an equipment grounding conductor connected between the inverter case and the grounding point in the AC load center. The AC Equipment Grounding Conductor (EGC – AC) is sized per Table 2-5 and is connected to the inverter’s AC equipment grounding terminal shown in figure 2-10.

DC Side - Since the currents on the DC side are higher than the AC side (10 times at 12 volts, 5 times at 24 volts), the equipment grounding needs are different. The DC Equipment Grounding Conductor (EGC – DC) is sized per Table 2-5 and connected to the DC equipment grounding terminal on the inverter shown in figure 1-2 (item 12).

Table 2-5, Equipment Grounding Conductor Sizing

Rating of Overcurrent Device	Minimum Size of Copper Ground Wire
15 amp	#14 AWG
20 amp	#12 AWG
30 - 60 amp	#10 AWG
100 amp	#8 AWG
200 amp	#6 AWG
300 amp	#4 AWG
400 amp	#3 AWG

Installation

2.6.4 Grounding on Boats

When installing the MS Series inverter/charger on a boat, there are several considerations that must be followed when grounding to ensure a safe installation, prevent galvanic corrosion and adhere to ABYC (American Boat and Yacht Council) standards.

Ensure a Safe Ground Connection

When AC on the boat is being supplied by shore power, the onboard neutral should be connected to safety ground on the dock. Consequently, neutral and safety ground should not be connected anywhere on the boat when shore power is present. When AC on the boat is being supplied by the MS Series inverter, the inverter's output neutral is connected to safety ground through an internal relay using its neutral to ground connection (shown in figure 2-20).

The DC ground terminal on the MS Series must also be connected to the boats safety ground bus. This ensures that both the inverters AC and DC ground terminals are connected to the boats safety ground bus as a safety measure to provide protection against faults and provide a path for AC fault currents while the boat is connected to shore power.

Preventing the Risk of Corrosion

The inverter's AC and DC ground terminals must be connected to the boats safety ground to provide an important safety feature. However, this ground connection introduces the risk of galvanic corrosion and/or electrolysis of the boat's underwater metallic hardware.

Two possible solutions are typically used to maintain the correct on-board grounding requirements while greatly reducing (if not eliminating) the risk of galvanic corrosion. These solutions would be either using a galvanic isolator or an on-board isolation transformer.

Galvanic Isolators allow high AC voltage faults to pass, but block low voltage corrosion/electrolysis currents from conducting.

Marine isolation transformers allow the shorepower to be connected to one side of the transformer and boat's AC wiring system is connected to the other side. Since transformers do not allow DC currents to pass, the problem with galvanic corrosion is eliminated.

ABYC Inverter/Charger Grounding Requirements¹

- **DC Grounding Connections:**

- 1) The DC grounding conductor (equipment ground) shall be:
 - a) connected from the metallic case or chassis of the inverter/charger to the engine negative terminal or its bus;
 - b) an ampacity equal to that of the DC positive conductor (under certain conditions, there is an exception to allow this conductor to be one size smaller - refer to the ABYC standard).
- 2) The inverter/charger's negative battery terminal and DC grounded conductor (negative cable) shall not be connected to the inverter case or chassis at the inverter/charger itself.

- **AC Grounding Connections:**

- 1) The AC grounding conductor (green) shall be connected to the inverter/charger in a manner so that the AC ground connection will not be disconnected in servicing. This conductor is in addition to and independent of the DC grounding conductor.
- 2) The neutral for AC power sources shall be grounded only at the following points:
 - a) the shore power neutral is grounded only through the shore power cable and not grounded on board the boat;
 - b) the inverter neutral shall be grounded at the inverter; and the output neutral shall be disconnected from ground when the inverter is operating in the charger/pass-through mode.
 - c) on systems using an isolation transformer or a polarization transformer, the inverter neutral (and the transformer secondary neutral) may be grounded at the AC main grounding bus instead of at the inverter.

Note 1: See the ABYC Standard for complete AC/DC grounding requirements.

2.6.5 Neutral to Safety Ground Bonding

The standards for safely wiring residential, commercial, RV/truck and marine installations in the United States require the neutral and safety ground be connected at the AC source; whether it is the utility feed in your home, an inverter, or a generator. This is to establish a specification that maximizes the possibility that a circuit breaker will activate if a hot-wire-to-ground fault occurs. These standards also require that the AC neutral be connected to safety ground (often called a bond) in one, and only one, place at any time. The single "bond" is established in order to make the electrical panel's neutral line safe, by connecting it to ground. Without this bond, the neutral can have up to 60 VAC with respect to ground. On the other hand, if more than one bond is established, currents can circulate between neutral and ground and cause "ground-loop" currents. These "ground-loops" can trip GFCIs, cause an electric shock hazard and may be the reason for other annoying side effects.

In applications where you are using an inverter as one of your AC sources along with another AC source (i.e., utility power or generator) there is the potential of having multiple connections ("bonds") between neutral and ground. Therefore, you must ensure that the inverter does not also connect the neutral-to-ground while the other AC source is actively powering the inverter loads. This can be prevented if your inverter is equipped with automatic neutral-to-ground switching.



WARNING: In most electrical systems, the neutral-to-ground "bond" is located in the main utility service entrance panel. Remove any "bond" downstream from the inverter to prevent multiple bonds. If there is an inverter subpanel - separate from a "main" electrical panel - it should have a removable wire that allows the neutral buss to be unbonded from the ground buss bar.

All MS Series Inverter/Chargers have automatic neutral-to-ground switching to specifically work in multiple source applications. The MS Series inverters use an internal relay that automatically connects the AC neutral output terminal to the vehicle/boat's ground while inverting (Inverter Mode) to provide the neutral-to-ground "bond"; as shown in figure 2-20. However, when an external AC source (i.e. shore power or a generator) is qualified, another neutral-to-ground connection is introduced in the system. When the MS Series is connected to this external AC source and goes into Standby Mode, the internal relay automatically opens the neutral-to-ground connection as shown in figure 2-21. This design keeps two neutral-to-ground connections from occurring at the same time, thereby preventing an electrical shock hazard between the vehicle/boat's neutral and the external AC source's neutral.

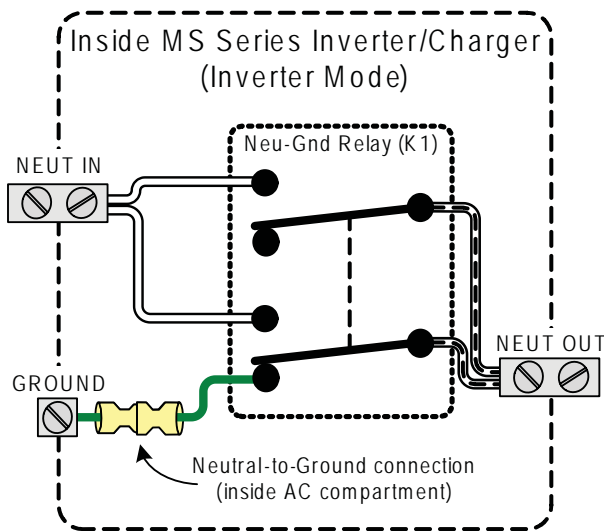

Figure 2-20, Neutral-to-Ground Connection (Inverter Mode)

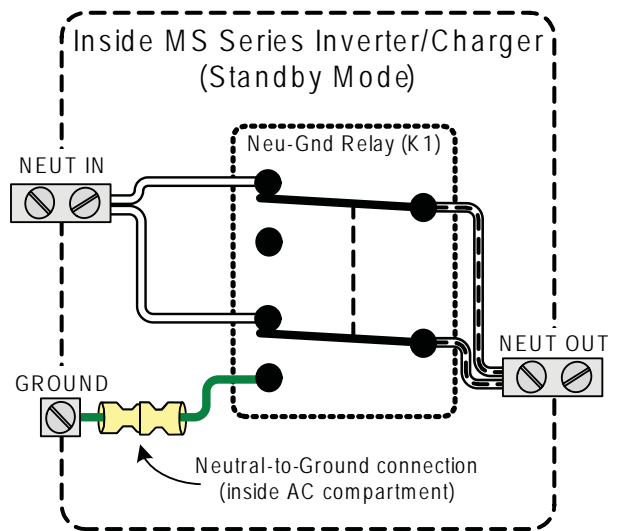

Figure 2-21, Neutral-to-Ground Connection (Standby Mode)

Installation

2.6.6 Disabling the Neutral-to-Ground Connection

All MS Series Inverter/Chargers have the automatic neutral-to-ground switching feature. In some installations/jurisdictions, this feature must be disabled. If you are not sure whether you must disable this feature, check your local code requirements. The following steps will guide you in disabling the neutral-to-ground switching feature in the MS Series inverter/charger.



Info: The ground connection from the inverter's AC and DC ground terminals should still be connected to the system ground even if ground switching has been disabled.



WARNING: Fire and Shock Hazard - Disconnect all AC and DC sources before working in the AC wiring compartment.

1. Locate and remove the AC access cover plate (shown as item 15, in figure 1-3) on the side of the MS Series inverter.
2. Look inside and locate the green wire with the insulated connector at the top of the AC wiring compartment; see Figure 2-22. This insulated connector connects the neutral and ground inside the inverter while inverting.
3. Pull the two ends of the insulated connector apart to separate the green wire; this will prevent the neutral and ground from connecting inside this inverter.
4. Move the two disconnected ends away from each other and push back out of the way. You must ensure that the two connector ends will not have any contact with any other wires within the AC compartment. You may want to use electrical tape to insulate the ends and secure them out of the way.

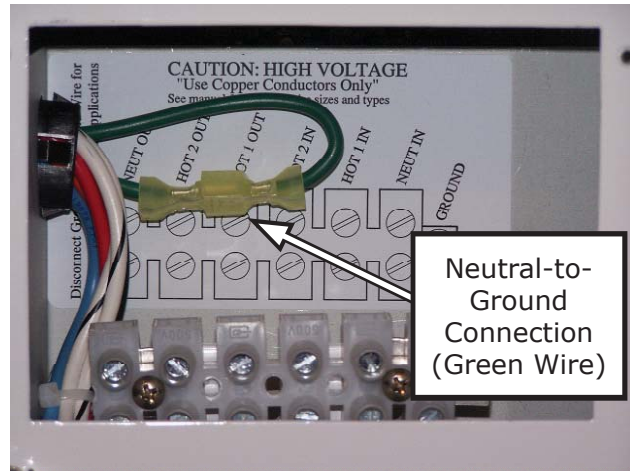

Figure 2-22, Disconnecting the Ground-to-Neutral connection

2.6.7 Connecting a Large Ground Wire

Marine installation require the ground wire to be the same size or one size smaller than the negative cable. Use the following steps to allow a larger ground wire to be connected.

1. Locate the DC ground terminal (shown as item 12, in figure 1-2).
2. Locate and remove the AC access cover plate (shown as item 15, in figure 1-3) on the side of the MS inverter.
3. Within the AC wiring area, locate the hex nut on the backside of the DC ground terminal. After locating the hex nut, use a 7/16' wrench/nut driver to remove the hex nut, bolt, lock washer and DC ground terminal and remove them from the chassis.
4. Reverse the removed bolt and place back in the chassis hole to attach a correctly sized ground cable to the MS Series chassis as shown in figure 2-23.
5. Place the washer and nut on the bolt over the ground cable and securely tightened the nut [from 4 to 5 ft lbf (5.4 to 6.8 N-m)].

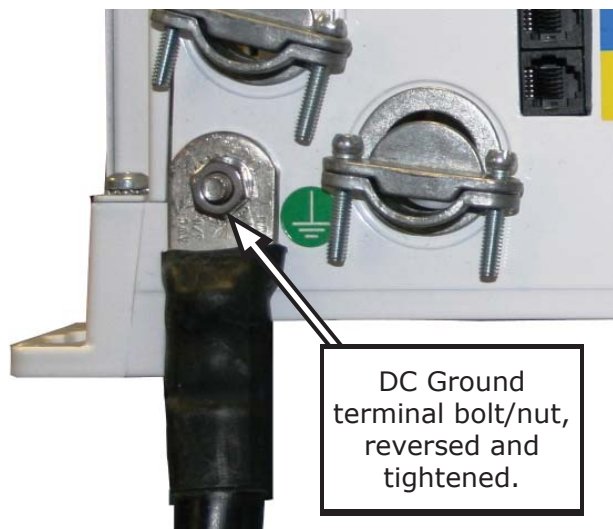

Figure 2-23, Large ground wire connected to MS Series

2.7 Inverter Notification Requirements

When an inverter is installed in a building, facility or structure, the NEC (National Electrical Code) requires a label or plaque to be provided. This label/plaque is required to be easily visible and provide information that informs personnel on the location of all electrical system disconnects. This is to ensure all power to a building is quickly located and shutdown in an emergency. There are also specific requirements for this label/plaque depending on the inverter application, they are as follows.

2.7.1 Facilities with Stand-alone Systems

Any building, facility, or structure with a photovoltaic power system that is not connected to a utility service source and is a standalone system must have a permanent plaque or directory installed on the exterior of the building or structure at a readily visible location acceptable to the Authority Having Jurisdiction (AHJ). The plaque or directory must provide the location of system disconnecting means and information regarding whether the structure contains a standalone electrical power system.

2.7.2 Facilities with Utility Services and PV Systems

Buildings, facilities, or structures with both utility service and a photovoltaic system must have a permanent plaque or directory providing the location of the service disconnecting means and the photovoltaic system disconnecting means if they are not located at the same location.

2.7.3 Inverter Warning Label

A warning label as shown in figure 2-24 is provided to inform all personnel that an inverter is installed in your electrical system. Affix this label in a clearly visible location at the electrical panel that is being powered by the inverter. This is because it might be falsely assumed that the panel is no longer "hot" after the AC power has been shut off, when power may actually still be available due to the inverter automatically powering the panel.

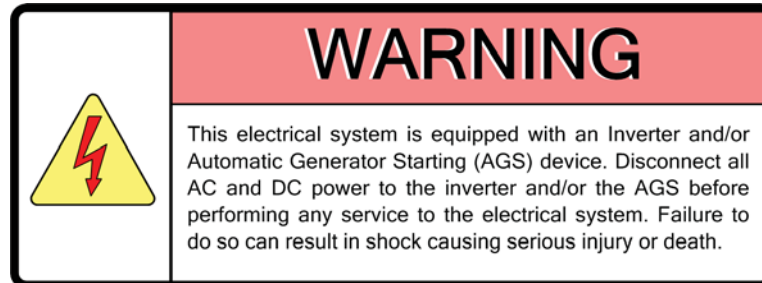

Figure 2-24, Warning Label

2.8 Final Inspection

1. Verify all cables/conduit runs are secured with wire ties or other non conductive fasteners to prevent chafing or damage from movement and vibration.
2. Verify strain reliefs or grommets are in place to prevent damage to the wiring or conduit where it passes through walls, bulkheads or other openings.
3. Verify all AC connections are correct and torqued to a maximum of 16 in lbf (1.8 N-m).
4. Replace the covers on the main electrical/distribution panel.
5. Replace the chassis access cover.
6. Verify the inverter's front panel switch is in the "OFF" position.



Info: If required by code, have the installation inspected by an electrical inspector.

Installation

2.9 Functional Test

After all electrical connections to the inverter, batteries, AC source, and sub-panel have been completed; follow these steps to test the installation and the inverter operation.



CAUTION: Use a multimeter to verify the correct DC voltage for your particular inverter model (i.e., 24-volt battery bank for a 24-volt inverter) and ensure the polarity of the battery voltage is correct (battery positive connected to inverter positive terminal and negative battery connected to inverter negative terminal).

1. Apply battery power to the inverter by closing the DC circuit breaker. The inverter will remain OFF, but the green status indicator on the front of the inverter will quickly blink once to indicate that DC power has been connected and is ready to be turned on.
2. Prior to turning on the inverter, make sure all AC loads (i.e., appliances) are NOT connected to the inverter's output or any AC outlets powered by the inverter.
3. Lightly press and release the inverter's ON/OFF switch to turn the inverter ON. Verify the inverter's status indicator is blinking - indicating the inverter is ON.
4. Connect a light bulb *no larger than 10 watts* to the inverter output and verify it comes on and shines normally. DO NOT connect anything but a light bulb, until all wiring and voltages are confirmed to be correct.



Info: The inverter's AC output voltage will not be correct until a load greater than 5 watts (5 watts is default setting) is connected to the inverter; or the search mode is turned OFF with a remote display (ME-RC). The 10 watt (or greater) light bulb is used because it is a sufficient load to bring the inverter out of "search" mode up to full voltage.

5. Check the AC output voltage of the inverter by connecting an AC voltmeter to the output terminals as shown in figure 2-25 and verify the correct output voltages.
6. Press and release the inverter's ON/OFF switch to turn the inverter off. The inverter's status indicator and the connected load should go off.
7. Apply AC power to the inverter's AC input. After the AC input power is qualified (approximately 15 seconds), the incoming AC power will transfer through the inverter to the inverter's AC output and power the light bulb. Verify the inverter's status indicator and the light bulb comes on.
8. Even though the light bulb is on, the inverter is currently disabled (off). Press and release the ON/OFF switch on the inverter to enable (turn-on) the inverter.
9. Disconnect the incoming AC power to the inverter. Verify the light bulb remains on and is now powered by the inverter.

If the inverter passes all the steps, the inverter is ready for use. If the inverter fails any of the steps, refer to the Troubleshooting section.

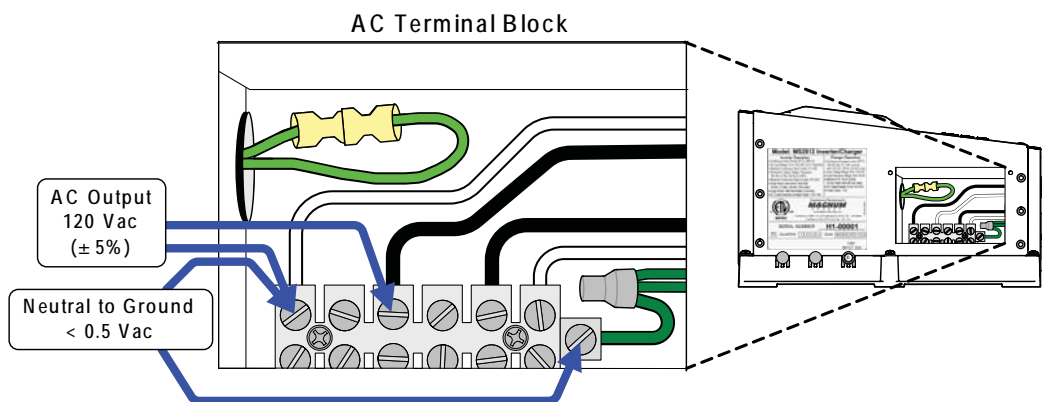

Figure 2-25, AC Voltage Checks

3.0 Operation

The MS Series inverter has two normal operating routines; 1. Inverter Mode, which powers your loads using the batteries, and 2. Standby Mode, which transfers the incoming AC Power (i.e., utility power or a generator) to power your loads and uses this incoming power to recharge the batteries. This inverter also includes an extensive protection circuitry to shut-down the inverter under certain fault conditions.

3.1 Inverter Mode

When the MS Series is first powered up, it defaults to the OFF mode. The momentary ON/OFF power switch (item 1 figure 1-1) must be lightly pressed to turn the inverter ON. Subsequently pressing this switch alternately turns the inverter OFF and ON.

Inverter OFF - When the inverter is OFF, no power is used from the batteries to power the AC loads and the status LED will be OFF. If AC power from an external source (Utility or Generator) is connected and qualified on the inverter's AC input, this AC input power will pass through the inverter to power the AC loads. However, if this AC power is lost, the AC loads will no longer be powered because the inverter is OFF.

When the inverter is turned ON, it operates either by "Searching" or "Inverting", depending on the connected AC loads.

Searching - When the inverter is first turned ON, the automatic Search feature is enabled. This feature is provided to conserve battery power when AC power is not required. In this mode, the inverter pulses the AC output looking for an AC load (i.e., electrical appliance). Whenever an AC load (greater than 5 watts) is turned on, the inverter recognizes the need for power and automatically starts inverting. When there is no load (or less than 5 watts) detected, the inverter automatically goes back into search mode to minimize energy consumption from the battery bank. When the inverter is "Searching", the inverter's green LED flashes (fast).



Info: The factory default value for the Search feature is 5 watts, it can be turned off or adjusted from 5 to 50 watts using the ME-RC remote display.

Inverting - When a load greater than 5 watts is connected to the inverter output, the MS Series "inverts" the DC power from the battery and supplies 120 VAC power to your sub-panel. The inverter's green LED flashes once every 2 seconds (medium flash) to indicate it is inverting. The amount of time the inverter can be inverting and provide power is directly related to the amount of AC loads that are connected and the capacity of the battery bank. Refer to figure 3-1 to see the flow of power from the DC input to the AC output while in the Inverter Mode.

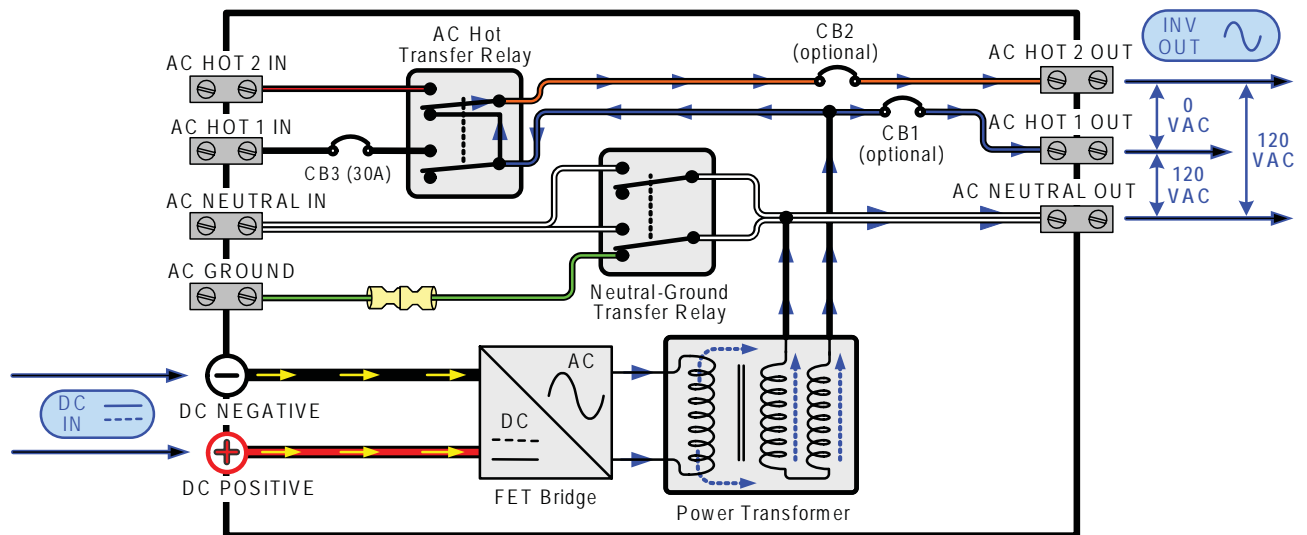

Figure 3-1, Power Flow - Inverter Mode

Operation

3.2 Standby Mode

The MS Series features an automatic transfer relay and an internal battery charger when operating in the Standby Mode. The Standby Mode begins whenever AC Power (Utility or Generator) is connected to the inverter's AC input. Once the AC voltage and frequency of the incoming AC power is within the AC input limits, an automatic AC transfer relay is activated. This transfer relay passes the incoming AC power through the inverter to power the AC loads on the inverter's output. This incoming power is also used to activate a powerful internal battery charger to keep the battery bank charged in case of a power failure. Refer to figure 3-2 to see the flow of power from the AC input to the DC and AC output while in the Standby Mode.

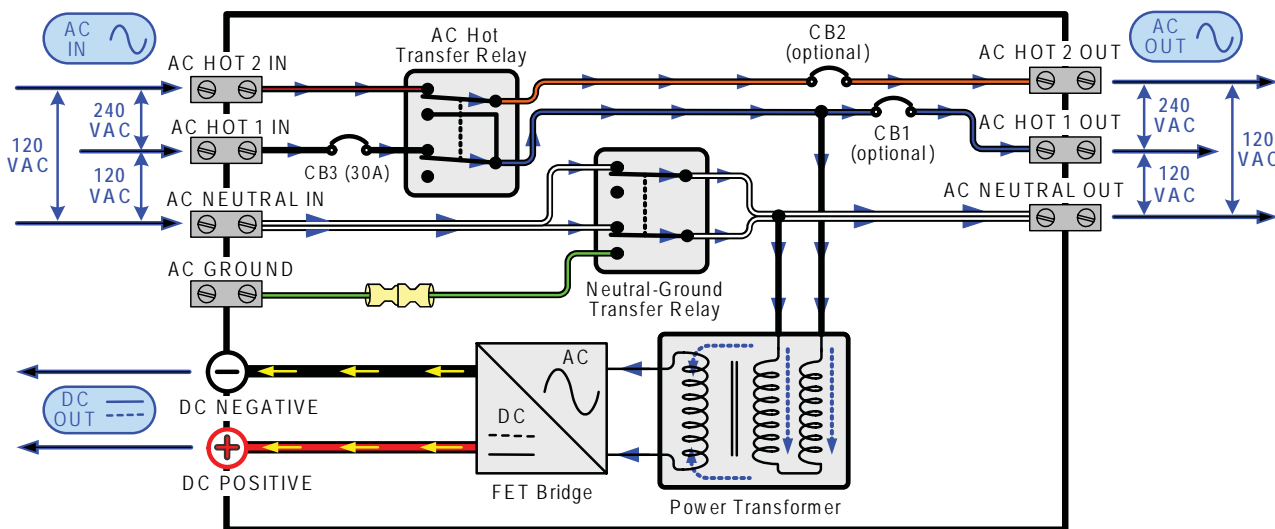

Figure 3-2, Power Flow - Standby Mode

3.3 Battery Charging

Magnum Energy's MS Series is equipped with an active PFC (Power Factor Corrected) and PI (Proportional-Integral) multistage battery charger. The PFC feature is used to control the amount of power used to charge the batteries in order to obtain a power factor as close as possible to 1 (or unity). This causes the battery charger to look like a resistor to the line (forces the charge current waveshape to mirror the voltage waveshape). The PI feature allows the charger voltage and current to change independently. These two features maximize the real power available from either utility or generator AC power sources, which translates into less power wasted and greater charging capabilities than most chargers available today.

When an AC source is connected to the AC input, the inverter begins monitoring for acceptable AC voltage. Once the inverter has accepted this AC voltage, the AC transfer relay closes and the Charge Mode begins. After Charge Mode begins, the DC voltage is monitored to determine the charging stage. If the DC voltage is low (≤ 12.8 VDC/12 volt models or ≤ 25.6 VDC/24-volt models), the charger begins Bulk Charging. If the DC voltage is high (> 12.8 VDC/12 volt models or > 25.6 VDC/24-volt), the charger will skip the Bulk and Absorb charging stages and go directly to Float Charging. The multistage charger can use up to five different charging stages to help monitor and keep the batteries healthy; The five stage include an automatic 4-stage charging process: Bulk, Absorb, Float and Full Charge; and a manual Equalization (EQ) charge stage. The automatic 4-stage charge process provides complete recharging and monitoring of the batteries without damage due to over charging. The EQ stage (requires the ME-RC remote to enable Equalization charge) is used to stir up stratified electrolyte and try and reverse battery plate sulfation that may have occurred.

While charging, the unit may go into Charger Back-off protection, which automatically reduces the charge current to the batteries. This is caused by: 1) The internal temperature is too hot - the charger automatically reduces the charge rate to maintain temperature; or 2) The AC input voltage falls below 90 VAC - the charger will stop charging to help stabilize the incoming AC voltage.

The Charge Mode provides up to four separate charging stages: Bulk Charging, Absorb Charging, Float Charging and Full Charge.

Bulk Charging: This is the initial stage of charging. While Bulk Charging, the charger supplies the battery with controlled constant current. The charger will remain in Bulk charge until the Absorption charge voltage (determined by the Battery Type selection*) is achieved. The inverter's green LED stays ON (solid) to indicate Bulk charging.

Absorb Charging: This is the second charging stage and begins after the absorb voltage has been reached. Absorb Charging provides the batteries with a constant voltage and reduces the DC charging current in order to maintain the absorb voltage setting. The inverter's green LED flashes once every second (fast flash) to indicate absorption charging for 2 hours (determined by the Battery AmpHrs selection*), then switches to Float Charging.

Float Charging: The third charging stage occurs at the end of the Absorb Charging time. While Float charging, the charge voltage is reduced to the float charge voltage (determined by the Battery Type selection*). In this stage, the batteries are kept fully charged and ready if needed by the inverter. The inverter's green LED flashes once every 8 seconds (slow flash) to indicate float charging. The float charging stage reduces battery gassing, minimizes watering requirements (for flooded batteries) and ensures the batteries are maintained at optimum capacity.

Full Charge (Battery Saver™ mode): The fourth stage occurs after four hours in the float charging stage. The Full Charge stage is designed to keep batteries fully charged over long periods and prevent excessive loss of water in flooded batteries or drying out of GEL/AGM batteries. In this stage, the charger is turned off and begins monitoring the battery voltage; if the battery voltage drops low (12.7 VDC or less on 12-volt models or 25.4 VDC or less on 24-volt models), the charger automatically initiates another four hours in Float Charge.



Info: If the battery voltage falls to the re-bulk voltage (12.1 VDC on 12-volt models or 24.2 VDC on 24-volt models) or lower, the unit will begin another Bulk charge.

* These settings in the MS Series are changeable and leave the factory with default values (see Table 3-2, Inverter/Charger Default Values). These default values are adequate for most installations, however, if you determine that some of the values need to be changed for your particular system, the ME-RC50 remote control may be purchased to adjust these settings.

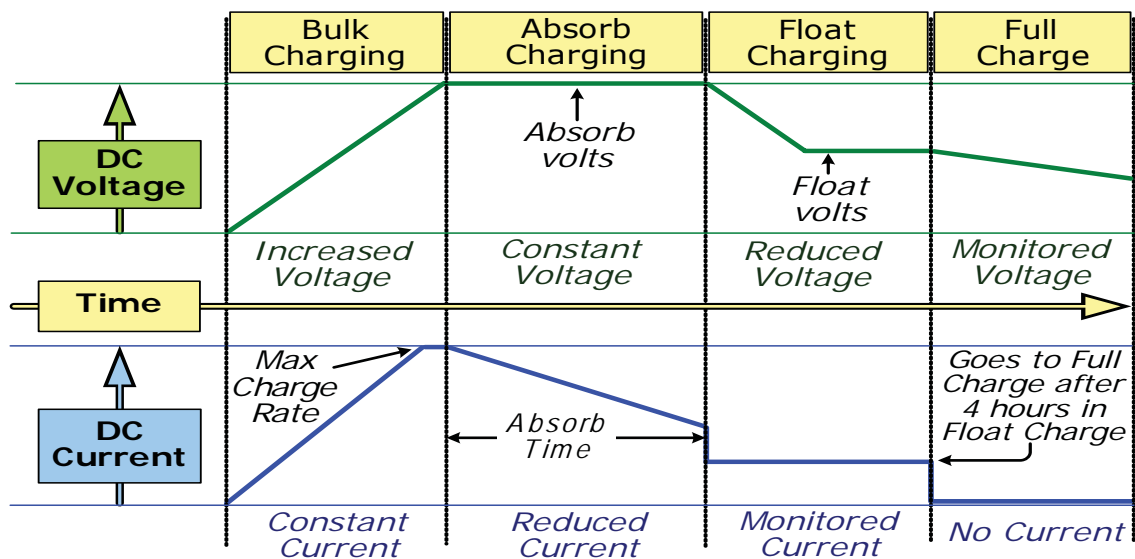

Figure 3-3, Automatic 4-Stage Charging Graph

Operation

3.4 Transfer Time

While in the Standby Mode, the AC input is continually monitored. Whenever AC power falls below the VAC Dropout voltage (80 VAC, default setting), the inverter automatically transfers back to the Invert Mode with minimum interruption to your appliances - as long as the inverter is turned on. The transfer from Standby mode to Inverter mode occurs in approximately 16 milliseconds. While the MS Series is not designed as a computer UPS system, this transfer time is usually fast enough to hold them up. However, the VAC dropout setting has an effect on the ability of the loads to transfer without resetting. The lower this setting, the longer the effective transfer will be and therefore, the higher the probability for the output loads to reset. This occurs because the incoming AC voltage is allowed to fall to a level that is so low - that when the transfer does occur - the voltage on the inverters output has already fallen low enough level to reset the loads.

The disadvantage of a higher VAC Dropout setting is that smaller generators (or large generators with an unstable output) may nuisance transfer. This commonly happens when powering loads that are larger than the generator can handle - causing the generator's output voltage to constantly fall below the inverters input VAC Dropout threshold.



Info: When switching from Inverter Mode to the Standby Mode, the inverter waits approximately 15 seconds to ensure the AC source is stable before transferring.

3.5 Battery Temperature Sensor Operation

The plug-in Battery Temperature Sensor (BTS) is used to determine the battery temperature around the batteries, this information allows the multistage battery charger to automatically adjust the battery charge voltages for optimum charging performance and longer battery life.

When the BTS is installed, if the temperature around the BTS is below 77°F (25°C) the Absorb and Float charge voltage increases and if the temperature around the BTS is higher than 77°F (25°C), the Absorb and Float charge voltage decreases. See figure 3-4 to determine how much the charge voltage changes (increases or decreases) depending on the temperature reading of the BTS. For example, the nominal Absorb charge voltage for a flooded battery at 77°F (25°C) on a 24-volt model is 29.2 VDC. If the battery temperature is 95°F (35°C), the Absorb charge voltage would decrease to 28.6 VDC (29.2 VDC - 0.6 change).

If the temperature sensor is NOT installed, the charge voltages will not be compensated and charges at a temperature of 77°F (25°C). The life of the batteries may be reduced if they are subjected to large temperature changes when the BTS is not installed.



Info: When the BTS is connected, the battery charger uses a value of -5mV/°C/Cell from 0-50°C to change the charge voltage based on temperature.

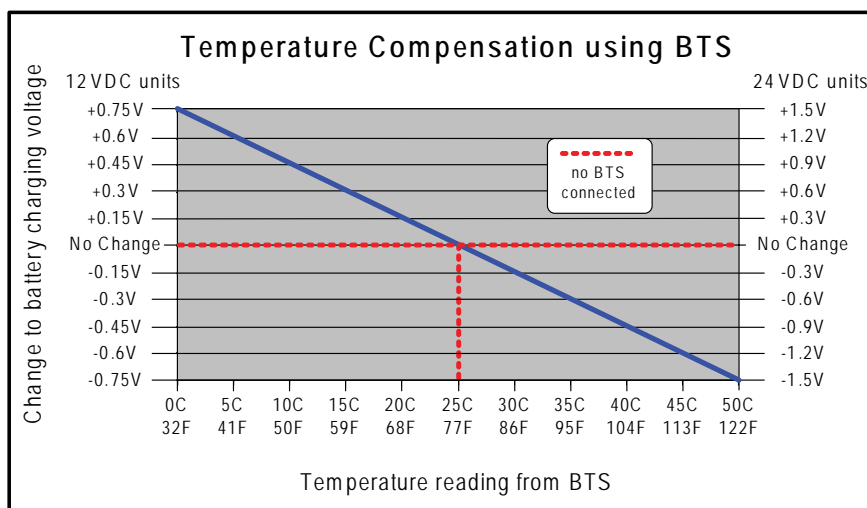

Figure 3-4, BTS Temperature to Charge Voltage Change

3.6 Protection Circuitry Operation

The inverter is protected against fault conditions and in normal usage it will be rare to see any. However, if a condition occurs that is outside the inverter’s normal operating parameters, then it will shut down and attempt to protect itself, the battery bank, and your AC loads. If there is a condition that causes the inverter to shutdown, it may be one of the following conditions [also refer to the Troubleshooting section (Section 4.3) to help diagnose and clear the fault condition].

- **Low Battery** - The inverter will shut off whenever the battery voltage falls to the **LBCO** (Low Battery Cut Out) level to protect the batteries from being over-discharged. After the inverter has reached the LBCO level and turned off, the inverter will automatically restart after one of the following conditions:
 1. AC Power is applied and the inverter begins operating as a battery charger.
 2. Battery voltage rises to the **LBCI** (Low Battery Cut In) level.

The inverter’s status LED turns off when a low battery fault condition occurs. Refer to Table 3-1 to determine the LBCO and LBCI levels for your inverter model.

- **High Battery** - In the event the battery voltage approaches the **HBCO** (High Battery Cut Out) level, the inverter will automatically shut down to prevent the inverter from supplying unregulated AC output voltage. The inverter’s status LED turns off when a high battery fault condition occurs. The inverter will automatically restart when the battery falls to the **HBCI** (High Battery Cut In) level. Refer to Table 3-1 to determine the HBCO and HBCI levels for your inverter model.



Info: High battery voltage may be caused by excessive or unregulated voltage from the solar panels or other external charging sources.

- **Overload** - During inverter and standby operation, the inverter monitors the DC and AC current levels. In the event of a short-circuit or an overload condition for more than a few seconds, the inverter will shut down. To start operating after this fault, the inverter would need to be restarted (turned back on) after the inverter’s AC loads are reduced/removed.
- **Over-temperature** - If internal power components begin to exceed their safe operating temperature level, the inverter will shut down to protect itself from damage. The inverter’s status LED turns OFF to indicate the over-temperature fault condition. The inverter will automatically restart after the units cools down.
- **Internal Fault** - The inverter continually monitors several internal components and the processor communications. If an condition occurs that does not allow proper internal operation, the inverter will shutdown to protect itself and the connected loads. The inverter will need to be reset to start operating, refer to section 4.4 for information on resetting the inverter.

Table 3-1, Inverter Battery Turn On/Off Levels

Inverter battery turn ON/OFF Levels	Inverter Model		
	MS2012	MS2812	MS4024
HBCO	16.8 VDC	16.8 VDC	33.6 VDC
HBCI	16.5 VDC	16.5 VDC	33.6 VDC
LBCI	12.5 VDC	12.5 VDC	25.0 VDC
LBCO* (1 minute delay)	10.0 VDC (9.0 - 12.2 VDC)	10.0 VDC (9.0 - 12.2 VDC)	20.0 VDC (18.0 - 24.4 VDC)
LBCO (immediate)	8.5 VDC	8.5 VDC	17.0 VDC

**adjustable with remote control*

Operation

3.7 Inverter Startup

ON/OFF Switch - The inverter can be turned on and off by lightly pressing and releasing the Power ON/OFF switch on the front of the inverter (refer to figure 3-5). When the inverter is first connected to the batteries, or when its automatic protection circuit has turned the inverter off, the ON/OFF switch will need to be pressed to start the unit (or reset per section 4.4). Once the inverter has been turned on, pressing the Power ON/OFF switch alternately turns the inverter on and off.



WARNING: The Power ON/OFF control switch does not turn on or off the charger feature. If AC power (Utility or generator) is connected and qualified on the AC input, this AC power will also be available on the AC output and is not controlled by the Power ON/OFF switch.

Status LED Indicator - The status indicator is a green LED (Light Emitting Diode) that provides information on the operational mode of the inverter. Watch this indicator (refer to figure 3-5) for at least 10 seconds to determine the inverter's operational condition from the information below:

- **Off** - Indicates the inverter is off; there is no AC power (inverter, utility or generator) at the inverter's output terminals. If the LED says off after pressing the ON/OFF switch, there is a "fault" condition such as low battery, high battery, overload, overtemperature or an internal fault. Refer to the Troubleshooting section to help diagnose/clear the fault condition.
- **Slow flash** (blinks on once every 8 seconds) - Indicates "float" charging; and the inverter is in Standby Mode (the external AC power that is connected to the inverters input is passing thru the inverter and is powering the AC loads connected to the inverter's output).
- **Medium flash** (blinks on once every second):
When AC power is not connected to inverter input - Indicates the inverter is on and using energy from the battery. The inverter is either: 1) Inverting - providing full power to the loads connected to the inverter; or 2) Searching - conserving power and waiting for a load to be turned on that meets or exceeds the Search Watts parameter (5 watts is the inverter default setting).
When AC power is connected to inverter input - Indicates "Absorb" charging; and the inverter is in Standby Mode (the external AC power that is connected to the inverters input is passing thru the inverter and is powering the AC loads connected to the inverter's output).
- **On (solid)** - Indicates "bulk" charging; and the inverter is in Standby Mode (the external AC power that is connected to the inverters input is passing thru the inverter and is powering the AC loads connected to the inverter's output).

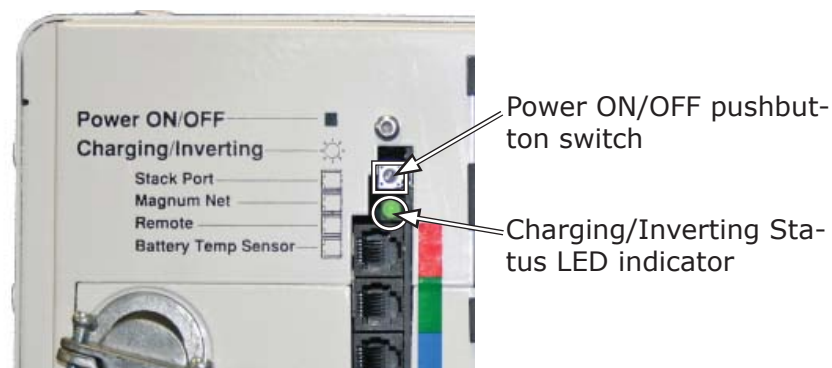

Figure 3-5, Power Switch and Status Indicator

3.8 Factory Default Values

Your MS Series inverter/charger uses default values for the adjustable settings (shown in Table 3-2) that are adequate for most installations. If some of your operating parameters need to be changed from the default values, the optional ME-RC remote control can be used to make those changes. To help you determine if you need the ME-RC remote display, information on the inverter/charger settings that can be changed is provided below. The settings once programmed are saved in the remote's nonvolatile memory and are preserved until changed - even if DC power to the inverter is lost (as long as the ME-RC remote is connected). For information on the full range of settings for each function, refer to the ME-RC Owner's Manual at www.magnumenergy.com.

- **Shore Max** - This setting ensures the inverter AC loads receive the maximum current available from the utility or generator power. When the total current used to power the AC loads and charge the batteries begins to approach the *Shore Max* setting, the current that was used for charging the batteries will automatically be reduced.
- **01 Search Watts**: This setting allows you to turn off the power-saving Search Mode circuitry or adjust the power level at which the inverter will "wake up" and start inverting.
- **02 LowBattCutOut**: This setting determines when the inverter will turn off based on low battery voltage. The inverter turns off automatically after the battery voltage has been below this setting for more than one minute. This protects the batteries from over-discharge and the AC loads from unregulated power (brown-outs).
- **03 Batt AmpHrs**: This setting allows the user to input the battery bank size in amp hours which tells the charger how long to charge the batteries in the Absorb charge stage.
- **04 Battery Type**: Sets the type of batteries being used in the system; this information tells the charger what voltage level to use to charge the batteries.
- **05 Charge Rate**: This setting can be used to turn off the charger, limit the amount of current that the charger can use (leaving more current available to power loads); or to ensure small battery banks are not overheated because of a charge rate that is too high.
- **06 VAC Dropout**: Sets the minimum AC voltage that must be present on the AC input before the unit transfers from Standby Mode to Inverter Mode. This protects the AC loads from utility outages and brown-outs.

Using the ME-RC remote also provides the following features:

- allows you to enable an equalize charge for certain battery types.
- displays inverter/charger's operating status
- provides fault information for troubleshooting

Table 3-2, Inverter/Charger Default Values

Adjustable Settings	Default Values
Shore Max	30 amps
01 Search Watts	5 watts
02 LowBattCutOut	10 VDC (12-volt models), 20 VDC (24-volt models)
03 Batt AmpHrs	600 Amp Hours (Absorb Time = 120 minutes)
04 Battery Type	Flooded - Liquid Lead Acid
05 Charge Rate	100%
06 VAC Dropout	80 VAC

4.0 Maintenance and Troubleshooting

The following information is provided to help you keep your MS Series Inverter/Charger in optimum operational condition.

4.1 Recommended Inverter and Battery Care

The MS Series inverter/ charger is designed to provide you with years of trouble-free service. Even though there are no user-serviceable parts, it is recommended that every 6 months you perform the following maintenance steps to ensure optimum performance and extend the life of your batteries.



WARNING: Prior to performing the following checks, switch OFF both the AC and DC circuits.

- Visually inspect the batteries for cracks, leaks, or swelling - replace if necessary
- Use baking soda to clean and remove any electrolyte spills or buildups
- Check and tighten all battery hold down clamps (if applicable)
- Clean and tighten all battery terminals and connecting cables [10 to 12 ft lbf (13.6 to 16.3 N-m)]
- Check and fill battery water levels (Liquid Lead Acid batteries only)
- Check individual battery voltages (load test those that have a voltage difference of more than 0.3 VDC from each other) - replace if necessary
- Check all cable runs for signs of chafing - replace if necessary
- Check the inverter's cooling vents - clean as necessary
- Check and tighten the inverter's internal AC terminal block connections [16 in lbf (1.8 N-m)]

4.2 Storage for Mobile Installations

When placing the RV, boat, or truck into storage, it is recommended that you perform the following to ensure the system is properly shutdown (or properly configured for storage). This is especially important for maintaining the batteries.

- Perform the recommended maintenance steps listed in Section 4.1.
- Fully charge the batteries.
- Connect AC power (if available) and verify the breaker to the inverter's input is switched ON (to allow battery charging).
- Verify the inverter is switched OFF.
- Switch OFF all unnecessary AC and DC loads.
- Disable the AGS (if installed) when the RV, boat or truck is in a confined storage area.



WARNING: If an AGS were to start and run the generator for an extended period of time in a confined area, a potentially fatal level of CO (Carbon Monoxide) could accumulate.

4.3 Troubleshooting

The MS Series inverter/charger is a fairly simple device to troubleshoot. There are only two active circuits (AC and DC) as well as a charging circuit. The following chart is designed to help you quickly pinpoint the most common inverter failures.

Table 4-1, Basic Troubleshooting		
Symptom	Possible Cause	Recommended Solution
No output Power. Inverter LED is OFF	Inverter is Switch OFF	Switch the inverter ON.
	Battery voltage is too low. The battery voltage level has dropped below the Low Battery Cutout (LBCO) set-point for more than one minute.	Check fuses/circuit-breakers and cable connections. Check battery voltage at the inverter's terminals. Your batteries may need to be charged, this fault condition will automatically clear when the battery voltage exceeds the LBCI voltage.
	The battery voltage is too high. The inverter automatically resets and resumes operation when the battery voltage drops to the HBCI voltage or lower.	This condition usually occurs only when an additional charging source (alternator, solar panels or other external charging sources) is used to charge the battery bank. Reduce or turn off any other charger to the inverter batteries to allow the voltage level to drop.
	Over-temperature condition: The internal temperature of the inverter has risen above acceptable limits; caused by loads too great for the inverter to operate continuously, or by lack of ventilation to the inverter. When the unit has cooled, it will automatically reset and resume operation.	Reduce the number of electrical loads that you are operating, this will avoid a repeat Overtemp shutdown if the cause was too many loads for the ambient conditions.
		Check ventilation around the inverter, ensure cool air is available to pass-thru the inverter (refer to the ventilation requirements in section 2.3).
	AC Overload condition: The inverter has turned off because the connected loads are larger than the inverters output capacity or the output wires are shorted.	Reduce the AC loads connected to the inverter or remove all AC output wiring and restart the inverter.
Internal fault: This fault occurs when an internal fault is detected.	To clear this fault, an inverter reset is required. Remove DC power to the inverter or press and hold down the power switch on the inverter for 15 seconds (until the green Status LED comes on). If this fault does not clear, the unit will need to be serviced.	
No output power. Green LED is flashing.	Unit is in "Search Mode", which means load is too small for search mode circuit detection.	Turn on load greater than 5 watts to bring inverter to full output power or turn off search with remote.
Low output or surge power. Green LED is flashing.	Loose or corroded battery cables.	Clean and tighten all cables.
	Low batteries.	Recharge or replace batteries.
	Loose AC output connections.	Tighten AC output connections.
	Battery cables are the wrong length or gauge.	Verify recommended cable lengths and gauges from the manual. Replace cables as necessary.
Low charging rate when connected to AC power.	Charge rate set too low.	Adjust charge rate or SHORE settings on remote.
	Low AC voltage (< 90 VAC).	Check AC input wiring.
Low charging rate when using a generator.	Generator output is too low to power both load and charger.	Reduce the load, increase the generator's RPMs.
		Check the SHORE settings (if remote connected).
Charger doesn't charge.	Loose or corroded battery cables.	Clean and tighten battery cables.
	Defective batteries.	Replace batteries.
	Wrong charger settings.	Adjust the charger settings, ensure the unit is not in charger standby.
	Wrong AC input voltage.	Verify proper AC input voltage and frequency.
While charging, the DC charge voltage is higher or lower than expected.	If the Battery Temperature Sensor (BTS) is installed, the DC voltage will increase or decrease depending on the temperature around the BTS.	This is normal; see section 3.3 (Battery Temperature Sensor Operation) for more information.

Maintenance and Troubleshooting

4.4 Resetting the Inverter

Under some fault conditions (i.e., an 'internal' fault), the inverter will need to be reset.

To reset the inverter:

Press and hold the Power ON/OFF pushbutton (see figure 4-1) for approximately fifteen (15) seconds until the Charging/Inverting Status LED comes on and flashes rapidly; once the rapid flashing has begun, release the Power ON/OFF pushbutton. The Status LED will go off after the pushbutton is released.

After the inverter reset is completed, press the ON/OFF pushbutton to turn the inverter ON.



Info: The Power ON/OFF pushbutton is a small *momentary* type switch which operates by lightly pressing and releasing.

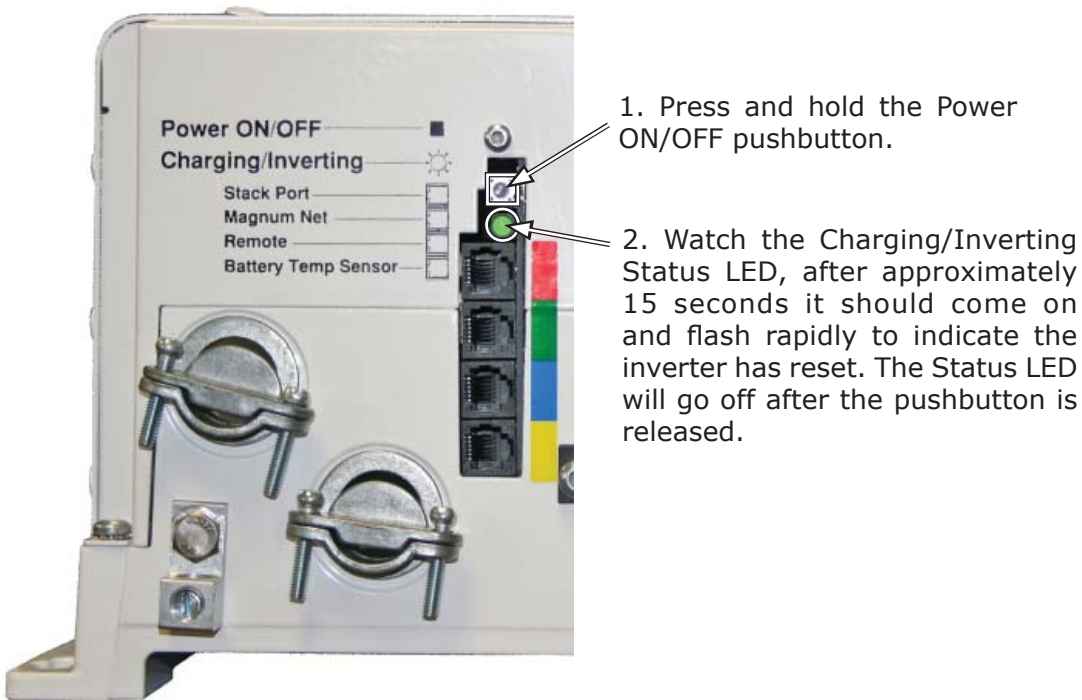

Figure 4-1, Performing an Inverter Reset

Appendix A - Specifications and Optional Equipment

A-1 Inverter/Charger Specifications

	MS2012 (-15B, -20B)	MS2812	MS4024
Inverter Specifications			
Input battery voltage range	9.0 to 16.8 VDC	9.0 to 16.8 VDC	18.0 to 33.6 VDC
Absolute maximum DC input	25 VDC	25 VDC	35 VDC
AC output voltage accuracy	120 VAC \pm 5% (\leq continuous power)		
Output frequency and accuracy	60 Hz \pm 0.1 Hz		
Total Harmonic Distortion (THD)	< 5%		
Continuous power output (at 25° C)	2000 VA	2800 VA	4000 VA
Continuous AC output current	17 A	23 A	33 A
1 msec surge current (amps AC)	50	70	120
100 msec surge current (amps AC)	33	40	82
5 sec surge power (real watts)	3300	3900	5800
30 sec surge power (real watts)	3100	3800	5400
5 min surge power (real watts)	2800	3200	4900
30 min surge power (real watts)	2200	3000	4500
Maximum continuous input current	222 ADC	311 ADC	222 ADC
Inverter efficiency (peak)	90.6%	90%	93.7%
HBCO/HBCI (High Battery Cut Out/In)	16.8 VDC/16.5 VDC	16.8 VDC/16.5 VDC	33.6 VDC/33.0 VDC
LBCO/LBCI (Low Battery Cut Out/In)	9.0 VDC (adj)/12.5 VDC	9.0 VDC (adj)/12.5 VDC	18.0 VDC (adj)/25.0 VDC
Series Stacking for 120/240 VAC	No	No	Yes, using two MS4024 units
AC Relay Transfer time (minimum)	16 msec		
Power Consumption - searching	<8 watts		
Power Consumption - inverting (no load)	25 watts	30 watts	25 watts
Output Waveform	Pure Sine Wave		
Charger Specifications			
Continuous charger output at 25°C	100 ADC	125 ADC	105 ADC
Input current for continuous rated output	15 AAC	18 AAC	29 AAC
Charger efficiency	85%		
AC input frequency range	50 to 70 Hz		
AC input voltage range	60 to 140 VAC (120 VAC nominal)		
Power factor	> 0.95		
General Features and Capabilities			
Transfer relay capability	30 AAC maximum each input (60 AAC total)*		
Five-stage charging capability	Bulk, Absorb, Float, Equalize (requires remote), and Battery Saver™		
Battery temperature compensation	Standard with available temp sensor connected (battery temp 0 - 50 °C)		
Internal Cooling	0 to 120 cfm variable speed drive using dual 92 mm brushless DC fan		
Overcurrent protection	with two overlapping circuits		
Overtemperature Protection	on transformer, MOSFETS, and temperature		
Corrosion protection	PCB's conformal coated, powder coated chassis/top, and stainless steel fasteners		
Safety Listings	ETL listed to UL/cUL STD 458, UL STD 1741 and CSA STD C22.2 No. 107.1-01		
Warranty	3 years parts and labor		
Branch rated output circuit breakers	only on MS2012 -15B (15A x2) and MS2012-20B (20A x2) models.		
Environmental Specifications			
Operating temperature	-20°C to +60°C (-4°F to 140°F)		
Non-Operating temperature	-40°C to +70°C (-40°F to 158°F)		
Operating humidity	0 to 95% RH non-condensing		
Physical Specifications			
Unit Dimensions (h x w x d)	13.75" x 12.65" x 8.0" (34.9 cm x 32.1 cm x 20.3 cm)		
Shipping Dimensions (h x w x d)	18.5" x 17.5" x 12.5" (47 cm x 44.5 cm x 31.8 cm)		
Mounting	Shelf or wall (vents not allowed to face downward unless ME-CB is installed)		
Unit Weight	43 lb (19.5 kg)	53 lb (24.0 kg)	58 lb (26.3 kg)
Shipping Weight	46 lb (20.9 kg)	56 lb (25.4 kg)	60 lb (27.2 kg)
Max operating altitude	15,000' (4570 m)		
* pass-thru on -15B and -20B models limited by output breakers			
Specifications @ 25°C - Subject to change without notice.			

Appendix A - Specifications

A-2 Inverter Efficiency

The following curves are plotted to show the MS Series efficiency over the full power range and is displayed as a percentage. This graph represents the inverter's efficiency while operating resistive loads. Motors and other inductive loads run less efficiently due to the impact of power factor losses.

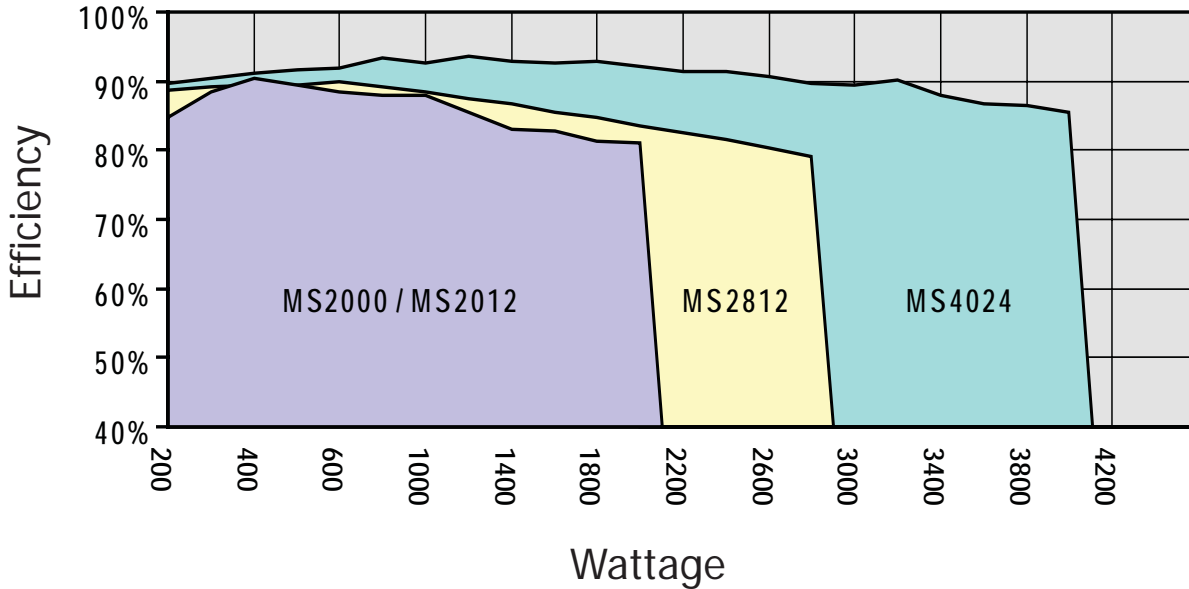

Figure 4-2, MS Series Efficiency Chart

A-3 AC Input Voltage to Output Charge Amps

The following chart shows the expected charger output capability of the MS Series. The maximum Charge current is dependent on the AC input voltage and the inverter battery voltage. Note: The output charger current shown is with the inverter battery voltage at nominal (i.e. 25.2 volts for MS4024).

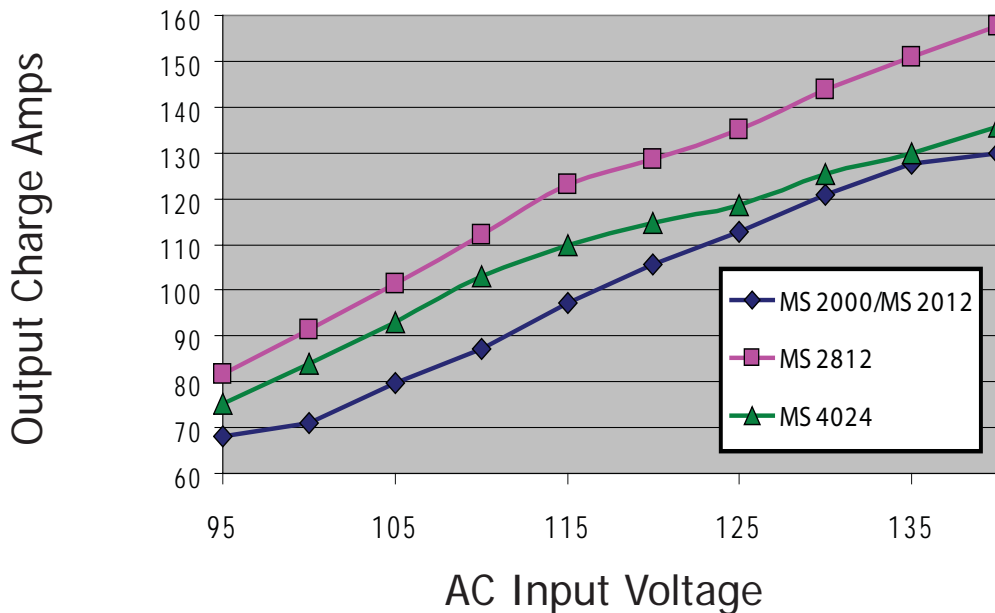

Figure 4-3, MS Series Output Charger Current Chart

A-4 Optional Equipment and Accessories

The following Magnum Energy components are available for use with the MS Series inverter/Charger. Some of these items are required depending upon the intended use of the inverter.

A-4.1 Automatic Generator Start (AGS) Controller

The Magnum Auto Gen Start controller is designed to automatically start your generator based on low battery condition or high temperature. The AGS controller includes an input voltage jumper (for 12, 24 and 48 volt battery banks) and a 4-position DIP (Dual In-line Package) switch which provides the ability to change the relay timing configurations to allow compatibility with a wide range of generators.

Adjustable settings include battery start voltage, start temperature, run time, and "Quiet Time" with an easy to set clock. AGS settings do not interfere with the manual start/stop operation of the generator.

Two models are available. The ME-AGS-S™ is the Stand-alone version for installation and operation without an inverter; or the ME-AGS-N™ which is the Network version, allowing operation of the AGS via the ME-RC Remote Control.

A-4.2 Fuse Block/Fuses

The Magnum Fuse/Fuse-block are used to protect the battery bank, inverter, and cables from damage caused by DC short circuits and overloads. They include a slow-blow, high current Class-T fuse with mounting block and protective cover, available in 300 and 400 amps.

A-4.3 Remote Control Display

The ME-RC™ Remote Control is simple to use; an easy-to-read LCD screen and "at a glance" LEDs display complete inverter/charger status. Soft keys provide simple access to menus and a rotary encoder knob allows you to scroll through and select a wide range of settings such as Inverter ON/OFF, Charger ON/OFF, Shore Power Breaker Setting, AGS Control, METER, SETUP and TECH menus.

A-4.4 Battery Monitor

The Battery Monitor Kit (ME-BMK™) is a single battery bank amp-hour meter that monitors the condition of the battery and provides information to let you know how much energy you have available and let you plan your electrical usage to ensure the battery is not being over-discharged.

A-4.5 Remote Switch Adapters

The ME-RSA™ and ME-RSA-M™ pigtail adapters allow the inverter to be remotely switched on and off - with or without the ME-RC remote display.

A-4.6 Conduit Box

The ME-CB™ conduit box connects to the front side of the inverter and allows conduit connections when required for the AC and DC wiring.

A-4.7 Battery Combiner

The Magnum Smart Battery Combiner (ME-SBC™) is designed to monitor and charge a second battery using a portion of the current that is charging a main battery. The ME-SBC eliminates a significant voltage drop and provides automatic turn on and off based on adjustable voltage setpoints; allowing different batteries to be charged from a single charging source and preventing over or under charging.

Appendix B - Battery Information

B-1 Battery Location

Periodic maintenance (i.e., checking connections, cleaning, watering) on batteries is required. Locate the batteries in an accessible location to perform this maintenance.

Batteries must be mounted in a clean, dry, ventilated environment where they are protected from high and low temperatures. The battery bank should be located as close to the inverter as possible without limiting access to the inverter's disconnects. Longer battery cable runs tend to lose efficiency and reduce the overall performance of an inverter.

To ensure optimum performance, a ventilated battery enclosure is recommended. Two feet of clearance above the batteries is recommended for access to the battery terminals and removable caps (lead acid battery types).



WARNING: Be very careful when working around batteries, they can produce extremely high currents if they are short-circuited. Read the important safety instructions at the beginning of this manual and the precautions from the battery supplier before installing the inverter and batteries.



CAUTION: Do not mount the batteries beneath the inverter (or in the same compartment). Batteries emit corrosive fumes which could damage the inverter's electronics. Never locate dedicated batteries near a vehicle/home fuel tank containing gasoline or propane.

B-2 Battery Types

Batteries are available in different sizes, amp-hour ratings, voltage and chemistries. They are also available for starting applications (such as an automobile starting battery) and deep discharge applications. Only the **deep cycle** types are recommended for inverter applications; using a starting battery in an inverter (deep cycle) application will greatly shorten their useful life. Choose the batteries best suited for the inverter installation and cost. Use only the same battery type for all batteries in the bank. For best performance, all batteries should be from the same lot and date. This information is usually printed on a label located on the battery.

B-3 Battery Temperature

Battery performance of lead-acid type batteries is greatly affected by extreme temperatures. When a lead-acid type battery is cold, its effective amp-hour capacity is reduced. When determining the battery requirements needed for the inverter system, realize that the battery capacity will be reduced if they will be installed in a climate where extremely cold temperatures are expected. In this type of environment, the batteries should be located in a heated area. At the minimum, the batteries should be installed in an insulated enclosure; which will keep the batteries warmer as they are being charged.

The battery bank should also be protected from high temperatures, which will shorten battery life. In high heat situations the battery room/enclosure should be ventilated to bring in cooler air and exhaust the hotter air. The performance of the battery bank/inverter system will substantially increase by monitoring and preventing extreme temperatures around the batteries.

B-4 Battery Bank Sizing

The size of the battery bank determines how long the inverter will power the AC loads without recharging. The larger the battery bank, the longer the run time. Size your battery bank to the systems AC load requirements and length of time required to run from the batteries. In general, the battery bank should not be discharged more than 50%. Additional DC charging devices such as solar, wind, hydro, etc., can provide longer run times by recharging the batteries in the absence of AC utility or generator power.



Info: For the MS Series inverter/charger to perform optimally, a minimum battery bank of 200 AH is recommended for moderate loads (<1000W) and greater than 400 AH for heavy loads (≥1000W).

B-5 Battery Bank Sizing Worksheet

Complete the steps below to determine the battery bank size required to power your AC loads:

1. Determine the daily power needed for each load

- a) List all AC loads required to run; and
- b) List the Watt-Hours for each load (see table B-1 for common loads/wattage); and
- c) multiply by how many hours per day (or a fraction of an hour) each load will be used; and
- d) multiply by how many days per week you will use the listed loads; and
- e) divide by seven = **Average Daily Watt-Hours Per Load.**

Average Daily Watt-Hours Per Load				
AC load	Watt-Hours	(x) hours per day	(x) days per week	(÷7) = total power

2. Determine the total power needed each day for all the loads.

- Add the *Average Daily Watt-Hours Per Load* together = **Total Daily Watt-Hours.**

Total Daily Watt-Hours

3. Determine the battery Amp-Hour capacity needed to run all the loads before recharging.

- Divide the *Total Daily Watt-Hours* by the nominal battery voltage of the inverter (i.e., 12, 24 volts); and
- Multiply this by how many days the loads will need to run without having power to recharge the batteries (typically 3 to 5 days of storage) = **Storage Amp-Hours.**

(inverter battery voltage)

÷ _____ =

(days of storage)

x _____ =

4. Determine how deeply you want to discharge your batteries.

- Divide the *Storage Amp-Hours* by 0.2 or 0.5 to get the **Total Amp-Hours:**
 - a) 0.2 = Discharges the batteries by 20% (80% remaining), this is considered the optimal level for long battery life; or
 - b) 0.5 = Discharges the batteries by 50% (50% remaining), this is considered a realistic trade-off between battery cost and battery life.

Total Amp-Hours

Additional compensation:

Low battery temperature: If the batteries are installed in a location that will be exposed to low temperatures, the available output will be less. In these instances, you will need to determine the lowest temperature the battery bank will experience and multiply the *Total Amp-Hours* by the Multiplier below.

Temperature	80F/27C	70F/21C	60F/15C	50F/10C	40F/4C	30F/-1C	20F/-7C
Multiplier	1.00	1.04	1.11	1.19	1.30	1.40	1.59

Inverter efficiency: When the inverter is used in a back-up power application the inverter efficiency will not be a large concern; however if the inverter is the primary AC source for the calculated load, the *Total Amp-Hours* should be multiplied by 1.2 to factor in an average 80% inverter efficiency.

Appendix B - Battery Information

B-6 Battery Wiring Configurations

The battery bank must be wired to match the inverter's DC input voltage. In addition, the batteries can be wired to provide additional run time. The various wiring configurations are:

B-6.1 Series Wiring

Wiring batteries in series increases the battery bank's output voltage. A series connection combines each battery in a string until the total voltage matches the inverter's DC requirement. Even though there are multiple batteries, the capacity remains the same. In figure B-1 below, two 6 VDC/200 AH batteries are combined into a single string resulting in a 12 VDC, 200 AHr bank.

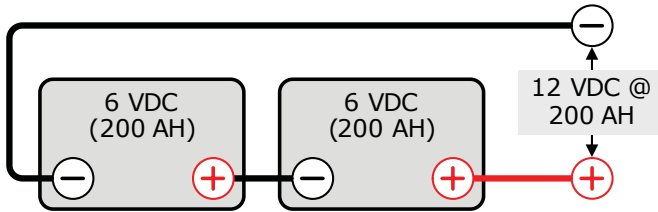

Series Battery Wiring

combines battery voltage:

$$\begin{array}{r} 200 \text{ AH @ } 6 \text{ VDC} \\ + \\ 200 \text{ AH @ } 6 \text{ VDC} \\ = \\ 200 \text{ AH @ } 12 \text{ VDC} \end{array}$$

Figure B-1, Series Battery Wiring

B-6.2 Parallel Wiring

Wiring batteries in parallel increases the battery bank's amp-hour capacity, which allows the AC loads to operate for a longer time. A parallel connection combines the number of batteries in the string to increase overall battery capacity; however, the voltage remains the same. In figure B-2 below, two 12 VDC/100 AH batteries are combined into a single 12 VDC, 200 AH battery bank.

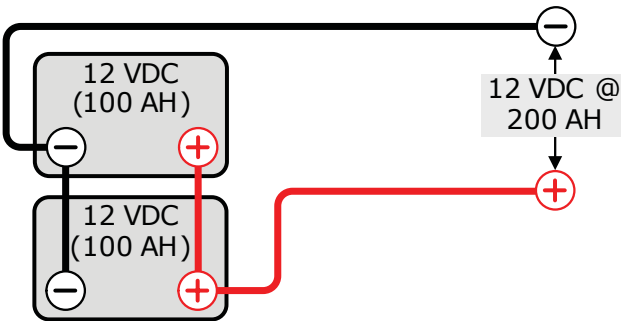

Parallel Battery Wiring

combines battery capacity:

$$\begin{array}{r} 100 \text{ AH @ } 12 \text{ VDC} \\ + \\ 100 \text{ AH @ } 12 \text{ VDC} \\ = \\ 200 \text{ AH @ } 12 \text{ VDC} \end{array}$$

Figure B-2, Parallel Battery Wiring

B-6.3 Series-Parallel Wiring

A series/parallel configuration increases both voltage (to match the inverter's DC requirements) and Amp-Hour capacity (to increase run-time for operating the loads) using smaller, lower-voltage batteries. In figure B-3 below, four 6 VDC/200 AH batteries are combined into two strings resulting in a 12 VDC, 400 AH battery bank.

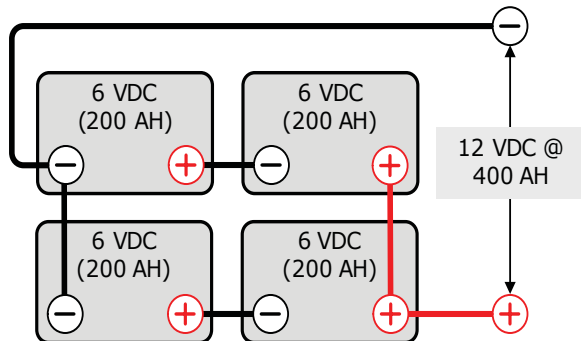

Series/Parallel Battery Wiring

combines battery voltage and capacity:

$$\begin{array}{r} 200 \text{ AH @ } 6 \text{ VDC} \\ + \\ 200 \text{ AH @ } 6 \text{ VDC} \\ = \\ 200 \text{ AH @ } 12 \text{ VDC} \\ + \\ 200 \text{ AH @ } 6 \text{ VDC} \\ + \\ 200 \text{ AH @ } 6 \text{ VDC} \\ = \\ 200 \text{ AH @ } 12 \text{ VDC} \\ \hline \\ \text{add voltage} \quad \text{add capacity} \\ \text{in series} \quad \text{in parallel} \\ \hline \\ \text{add voltage and} \\ \text{capacity together} \end{array}$$

Figure B-3, Series-Parallel Battery Wiring

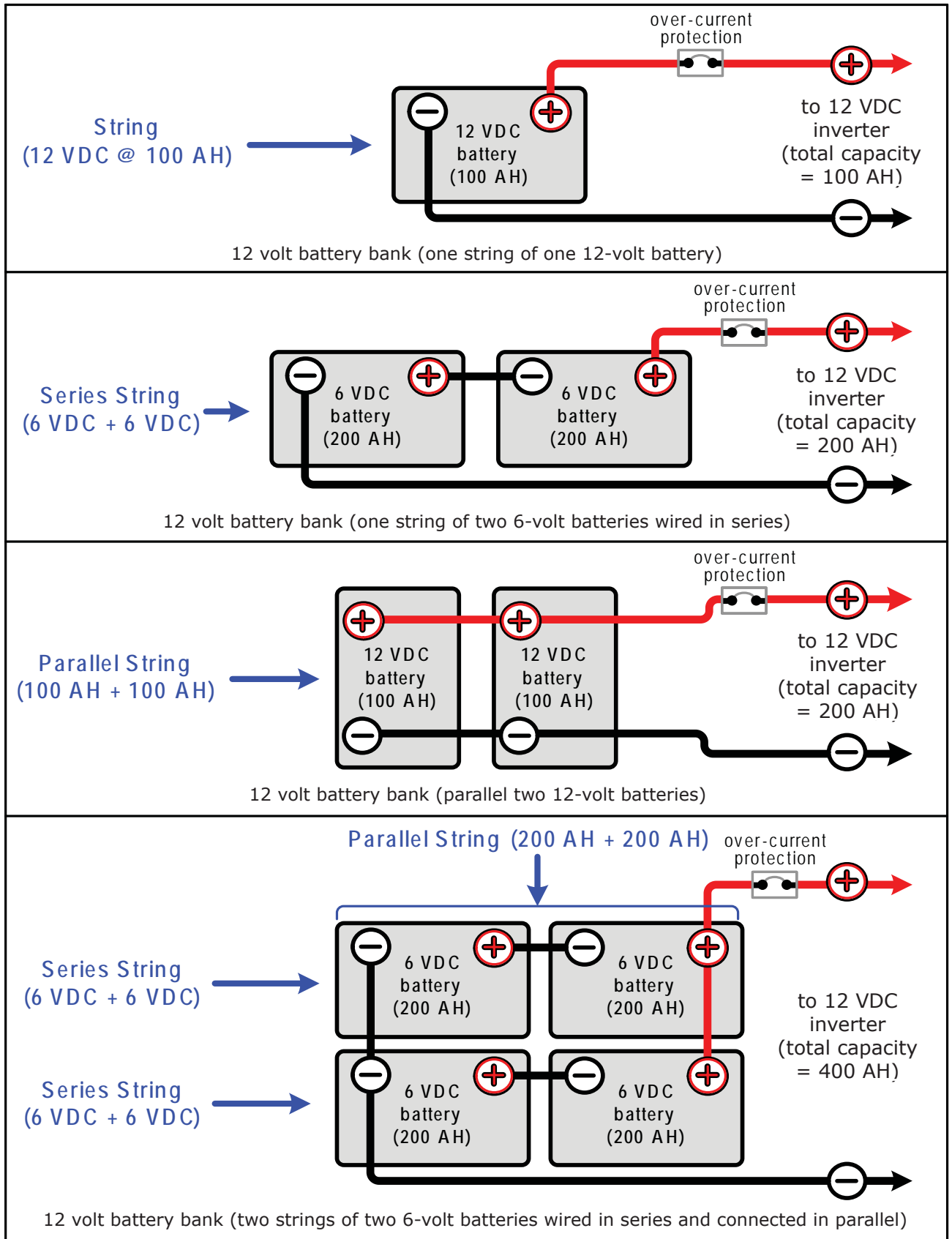

Figure B-4, Battery Bank Wiring Examples (12-volt)

Appendix B - Battery Information

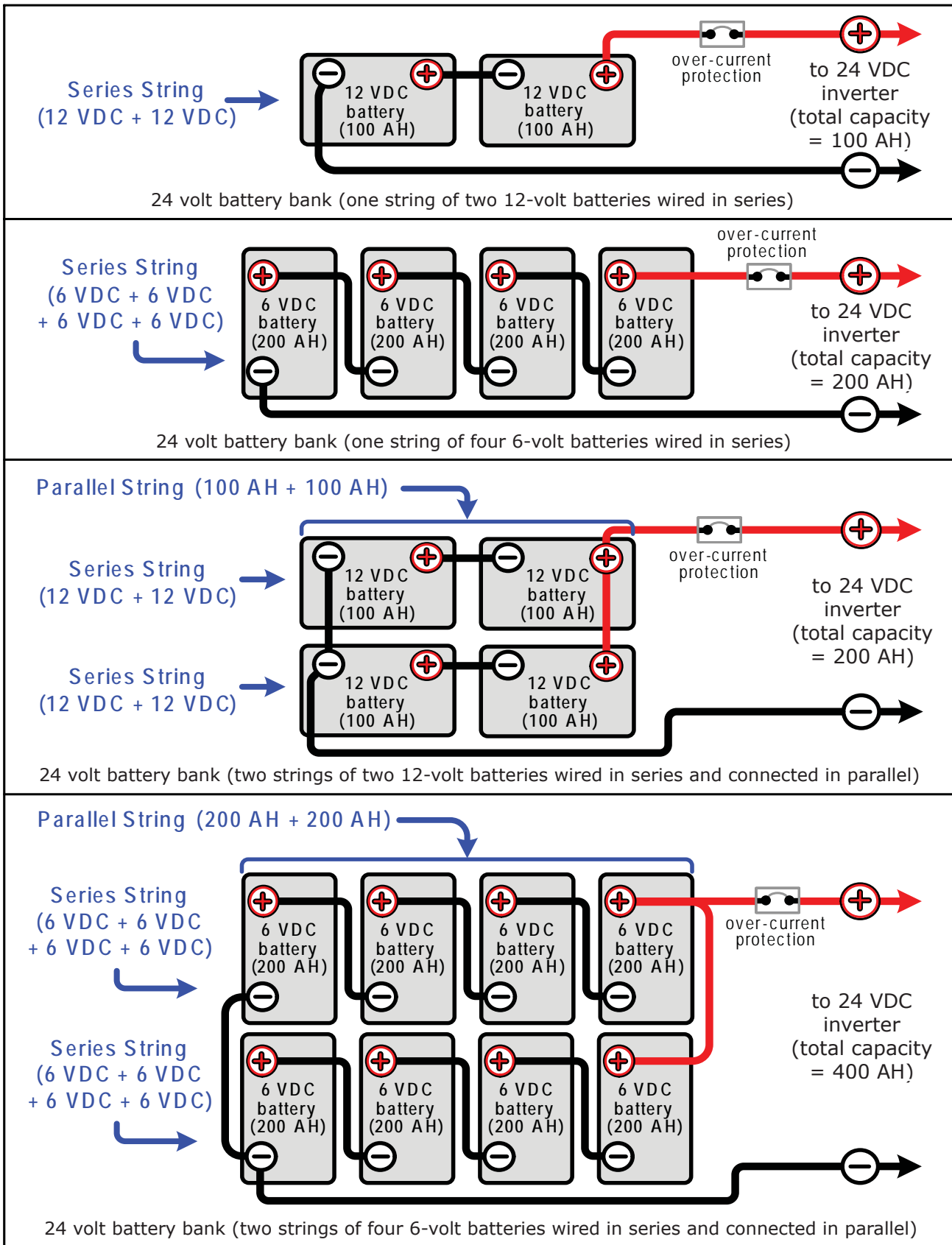

Figure B-5, Battery Bank Wiring Examples (24-volt)

Limited Warranty

Magnum Energy, Inc., warrants the MS Series Inverter/Charger to be free from defects in material and workmanship that result in product failure during normal usage, according to the following terms and conditions:

1. The limited warranty for the product extends for 36 months beginning from the product's original date of purchase.
2. The limited warranty extends to the original purchaser of the product and is not assignable or transferable to any subsequent purchaser.
3. During the limited warranty period, Magnum Energy will repair, or replace at Magnum Energy's option, any defective parts, or any parts that will not properly operate for their intended use with factory new or rebuilt replacement items if such repair or replacement is needed because of product malfunction or failure during normal usage. The limited warranty does not cover defects in appearance, cosmetic, decorative or structural parts or any non-operative parts. Magnum Energy's limit of liability under the limited warranty shall be the actual cash value of the product at the time the original purchaser returns the product for repair, determined by the price paid by the original purchaser. Magnum Energy shall not be liable for any other losses or damages.
4. Upon request from Magnum Energy, the original purchaser must prove the product's original date of purchase by a dated bill of sale, itemized receipt.
5. The original purchaser shall return the product prepaid to Magnum Energy in Everett, WA. After the completion of service under this limited warranty, Magnum Energy will return the product prepaid to the original purchaser via a Magnum-selected non-expedited surface freight within the contiguous United States and Canada; this excludes Alaska and Hawaii.
6. This limited warranty is voided if:
 - the product has been modified without authorization.
 - the serial number has been altered or removed.
 - the product has been damaged from abuse, neglect, accident, high voltage or corrosion.
 - the product was not installed and operated according to the owner's manual.

How to Receive Repair Service

If your product requires warranty service or repair, contact either:

1. An Authorized Service Center, which are listed on the Magnum Energy website at www.magnumenergy.com/servicecenters.htm; or
2. Magnum Energy, Inc. at:

Telephone: 425-353-8833

Fax: 425-353-8390

Email: warranty@magnumenergy.com

If returning the product directly to Magnum Energy for repair, you must:

- Return the unit in the original, or equivalent, shipping container.
- Receive a Return Materials Authorization (RMA) number from the factory prior to the return of the product to Magnum Energy for repair.
- Place RMA numbers clearly on the shipping container or on the packing slip.

**BEFORE RETURNING ANY UNIT TO MAGNUM ENERGY INC.,
A RETURN MATERIAL AUTHORIZATION (RMA) NUMBER IS REQUIRED.**



Magnum Energy, Inc.
2211 West Casino Rd.
Everett, WA 98204
Phone: 425-353-8833
Fax: 425-353-8390
Web: www.magnumenergy.com