



TT2602

F-53 20-22K GVW Chassis Rear Bar Kodiak 4500-5500 Chassis Rear Bar Installation Instructions

Each installation may vary due to chassis manufacturing options and variations in design. The rod assembly may be installed in several different combinations, such as either front or rear of the supplied brackets as well as using different bracket holes. The important thing is to maintain clearance between your trac bar and any chassis component (moving and stationary) such as exhaust, vehicle frame, differential, or any other item which might interfere with the operation of this product. Pictures and diagrams may not represent the best installation for every application.

Bolt Torque Specifications		
Torque in Foot-Pounds for Inch Bolts		
Bolt Size	Grade 5	Grade 8
1/4"	10	14
5/16"	19	29
3/8"	33	47
7/16"	54	78
1/2"	78	119
5/8"	154	230
3/4"	257	380



Bolt Torque Specifications		
Torque in Foot-Pounds for Metric Bolts		
Bolt Size	Grade 8.8	Grade 10.9
6MM	6	8
8MM	16	22
10MM	31	40
12MM	54	70
14MM	89	117
16MM	161	230
18MM	222	318

Bolt Torque Specifications		
Torque in Foot-Pounds for Grade 5 U-Bolts		
Bolt Size	Fine	Course
3/8"	21	18
7/16"	33	29
1/2"	52	45
5/8"	107	91
3/4"	190	165
7/8"	304	270

*Always tighten and torque u-bolts in a cross pattern sequence.

NOTICE

- Only a qualified mechanic using normal automotive tools and following all safety standards should perform the installation of this product.
- If the vehicle is equipped with air bags be sure that nothing interferes with the deployment of them.
- Be sure to use a sufficient amount of Loctite® Red on all bolts before tightening. Tighten all bolts according to the torque charts provided or to the manufacturer's torque specifications on OEM parts. If no manufacturer specifications can be found then use the torque charts provided.
- Dealer or installer be certain the user receives these instruction sheets.

TT2602
 F-53 20-22K GVW / Kodiak 4500-5500 Chassis Rear Bar
 Installation Instructions

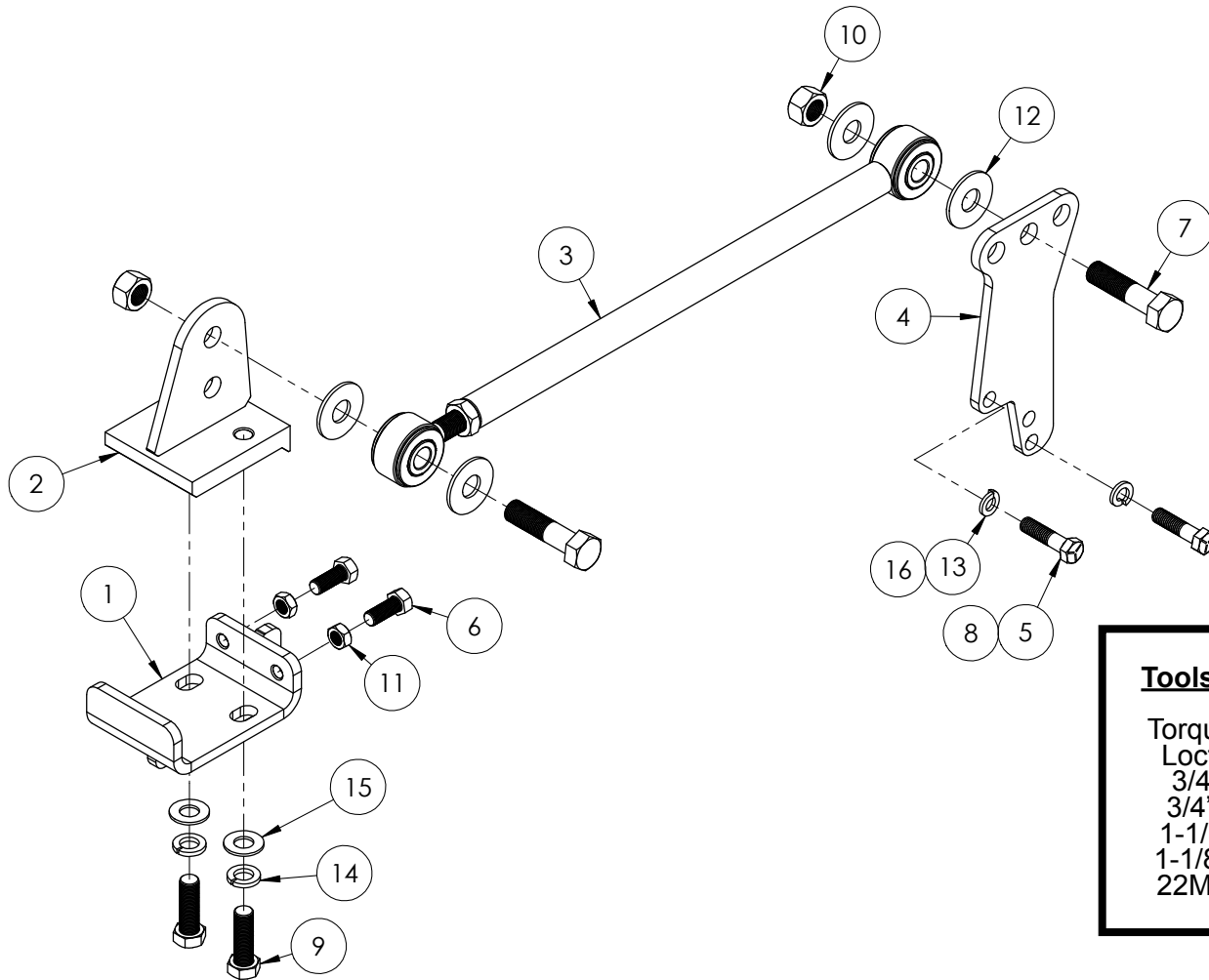

Tools Required

Torque Wrench
 Loctite® RED
 3/4" Socket
 3/4" Wrench
 1-1/8" Socket
 1-1/8" Wrench
 22MM Socket

Item No.	Part Number	Description	Qty.
1.....	61-6745.....	Frame Bracket.....	1
2.....	61-6746.....	Nut Plate Frame Bracket.....	1
3.....	62-3633.....	Rod Assembly.....	1
4.....	101-8743.....	Differential Bracket.....	1
5.....	201-0283.....	1/2"-13 x 2" Hex Head Bolt, Grade 5, ZP.....	2
6.....	201-0308.....	1/2"-20 x 1-1/4" Hex Head Bolt, Grade 5, ZP.....	2
7.....	201-0632.....	3/4"-16 x 3" Hex Head Bolt, Grade 5, ZP.....	2
8.....	201-0813.....	14MM-2MM x 50MM Hex Head Bolt, Grade 10.9.....	2
9.....	201-0912.....	5/8"-18 x 2" Hex Head Bolt, Grade 5, ZP.....	2
10.....	202-0168.....	3/4"-16 Stover Lock Nut, ZP.....	2
11.....	202-0184.....	1/2"-20 Jam Hex Nut, Grade 5, ZP.....	2
12.....	203-0007.....	3/4" Flat Washer, ZP.....	4
13.....	203-0012.....	1/2" Lock Washer, ZP.....	2
14.....	203-0013.....	5/8" Lock Washer, ZP.....	2
15.....	203-0106.....	5/8" SAE Flat Washer, ZP.....	2
16.....	203-0131.....	14MM Lock Washer, ZP.....	2

Important:

Use only genuine factory replacement parts on your trac bar. Do **NOT** substitute homemade or non-typical parts. If a bolt is lost or in need of replacement, for your safety and the preservation of your trac bar, be sure to use a replacement bolt of the same grade (In most cases it will be Grade 5, please reference the parts list above). Replacement parts may be ordered through your nearest Blue Ox® Dealer or Distributor.

F-53 20-22K GVW / Kodiak 4500-5500 Chassis Rear Bar Installation Instructions

Installation Instructions

1. Position the vehicle on a level surface with the front wheels straight ahead and sitting at normal ride height. Set the brake and chock all the wheels.
2. Hold the axle bracket up to the rear end to locate the two (2) OEM bolts that line up to the bracket. Remove the OEM bolts and install the bracket to the rear end with the supplied bolts and lock washers. If the rear end had flat washers, reuse the washers in between the bracket and the rear end housing. Tighten all bolts.
3. Position the frame bracket onto the passenger side frame rail and loosely secure it with the nut plate frame bracket and the 5/8"-18 x 2" bolts with 5/8" lock and flat washers. Loosely install the two (2) 1/2"-20 x 1-1/4" bolts with the 1/2"-20 jam nuts into the frame bracket. The bracket needs to be loose enough on the frame rail to move back & fourth to line up with the axle bracket.
4. Install the rod assembly onto the front of the axle bracket with one (1) 3/4"-16 x 3" bolt, four (4) 3/4" flat washers and a 3/4" lock nut. Put one (1) washer on the outside of the bushing and the other three (3) between the bushing and axle bracket. Position the frame bracket so it is straight with the axle bracket and rod assembly. Adjust the length of the rod assembly until you are able to pass a bolt thru both the rod assembly and frame bracket. Install a 3/4" bolt, flat washer and a 3/4" lock nut into the rod assembly and frame bracket. Be sure the flat washer is in between the urethane bushing and nut. Leave all bolts finger tight for now.
5. Once the frame bracket is straight with the rod assembly and axle bracket, alternately tighten down the 5/8" bolts on the frame bracket and torque to specifications. Then torque the 1/2"-20 x 1-1/4" bolts to the frame and tighten the jam nuts.
6. Torque the 3/4" bolts in the rod assembly to specifications. Inspect for any wiring or hoses that may rub against the brackets and secure in a safe position with the loom and/or cable ties provided.

CUSTOMER SERVICE COMMITMENT

Blue Ox® is committed to providing you with exceptional customer care throughout your lifetime with our products. Our team is here to assist you with any questions you may have regarding the performance of your product. Simply call (402) 385-3051 and you can speak with our technical service team.

Additionally, please visit our website to see which rallies our Destination America team will be attending. For a nominal fee, our service technician will service your towing system to ensure it's in proper working condition. Also, as a commitment to our customers, should you visit our factory, you can stay at our full service Blue Ox® campground at no charge along with enjoying a factory tour.

Again, thank you for being our customer and for the confidence you have shown in the performance of our products. It is because of customers like you we enjoy the success we have today.



© 2016 Blue Ox
One Mill Road, Industrial Park
Pender, Nebraska 68047
Phone: (402) 385-3051
Fax: (402) 385-3360
www.blueox.com